



## SUPER-OPEN MILLING VISE

Model: H-400, 600, 800

8" JAW OPENING ON H-400 VISE

11" JAW OPENING ON H-600 VISE

14" JAW OPENING ON H-800 VISE

Except the Hydraulic System, it has almost the same features with HH-Type HYDRAULIC MACHINE VISE.

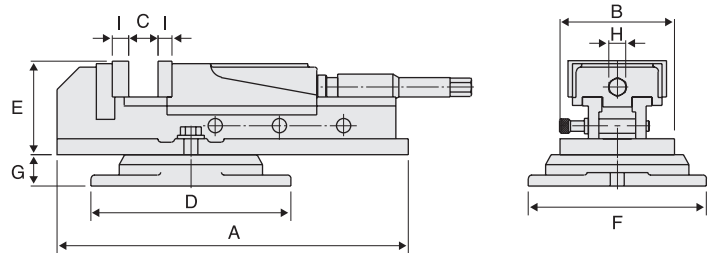

Unit: mm / inch

### SPECIFICATIONS

Model	A		B		C		D		E		F		G		H		I		Weight (kg)
H-400	394	1533/64	148	553/64	200	8	224	813/16	105	4	204	41/8	35	13/8	19	3/4	15	19/32	19
H-600	535	211/16	200	77/8	275	11	280	111/64	142	519/32	256	105/64	32	11/4	19	3/4	15	19/32	45
H-800	605	2313/16	250	10	336	14	336	1315/64	144	543/64	300	1113/16	40	137/64	19	3/4	15	19/32	75



## TILTING SUPER-OPEN VISE

Model: HHY-100, 150

Our most popular angle milling vise

- Tilts up and down.
- Base swivels.
- High quality casting with ground finish.
- Easy and light operating, 4 holes can be firmly clamped quickly.
- Type HHY-150 jaw's opening 310mm, 2 times larger than the normal milling vises.
- Except the Hydraulic system, it has almost the same features with HW-Type HYDRAULIC MACHINE VISE.

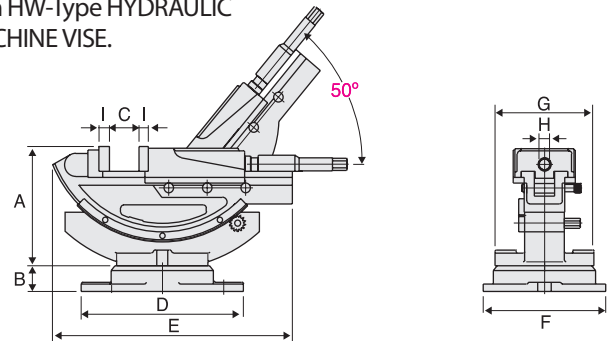

Unit: mm

### SPECIFICATIONS

Model	A	B	C	D	E	F	G	H	I	Weight (kg)
HHY-100	195	42	170	270	405	228	168	19	15	37
HHY-150	214	40	310	336	485	300	238	19	15	64