

450 mm / 650 mm / 1000 mm 階規
CHECK MASTER



標準規格 Check Master			
型號 Model No.	CW-450L	CW-650L	CW-1000L
精確度 Accuracy	≤ 2 um	≤ 3 um	≤ 6 um
量測範圍 Range	0~450 mm	0~650 mm	0~1000 mm
環境溫度 Temperature	T = 20 ± 1°C		

垂直儀
VERTICAL TESTER



型號 Model No.	V-300	V-600
量測範圍 Range	0~300 mm	0~600 mm
精確度 Accuracy		
真直度 Straightness	≤ 3 um	≤ 5 um
垂直度 Squares	≤ 3 um	≤ 5 um
操作方式 Operation	手動 Manual	手動 Manual
重量 Weight	8Kg	10Kg
環境溫度 Temperature	T=20 - 23°C	T=20 - 23°C

 建緯精密科技股份有限公司
CHIEN WEI PRECISE TECHNOLOGY CO., LTD.

台灣高雄總公司地址：高雄市鳳山區 83041 鎮北里鎮北北巷 20-16 號
HEADQUARTERS : No. 20-16, Chen Pei N. Lane,
Fengshan District, Kaohsiung City 83041, Taiwan.
TEL : 886-7-7313911 FAX : 886-7-7314976
E-Mail : info@chienwei.com.tw http://www.chienwei.com/
桃園辦事處：334 桃園市八德區豐田七街 35 號
電話：886-3-3681739；傳真：886-3-3680094
E-MAIL:taoyuan@chienwei.com.tw
台中辦事處：406 台中市北屯區軍福 18 路 13 號
電話：886-4-2436-6250；傳真：886-4-2439-2589
E-MAIL:taichung@chienwei.com.tw
昆山長豐精密儀器有限公司
KUNSHAN CHANGFENG PRECISE INSTRUMENTS CO., LTD.
江蘇省昆山市張浦鎮大市中吉山路 12 號
TEL: 86-512-57258001 FAX : 86-512-57258006
E-Mail : kschangfeng@163.com



※本公司保留對此型錄做修改之權利，修改時恕不另行通知。(2022-3)
※Chien Wei reserves the right to change specifications without notice.



建緯精密科技股份有限公司
CHIEN WEI PRECISE TECHNOLOGY CO.,LTD.

三次元坐標量測儀器
3D coordinate measuring machine



3axis

目次 CONTENTS

- P.2 UCC
- P.3 測頭運用及分解
- P.4 非接觸影像系統選購介紹
- P.5 量測軟體介紹
- P.6 IK5000 之運用
- P.7 ZEPHYR II 3D 雷射頭
- P.9 CWB-450 / CWB-450V
- P.10 CWB-450-CNC / CWB-450V-CNC
- P.11 CWB-450DV / CWB-450DV-CNC
- P.12 CWB-554AV / CWB-554AV-CNC
- P.13 CWB-775A / CWB-775AV
- P.14 CWB-775A-CNC / CWB-775AV-CNC
- P.15 CWT-544A-CNC / CWT-544AV-CNC
- P.16 CWT-875A-CNC / CWT-875AV-CNC
- P.17 CWT-1000A-CNC / CWT-1000AV-CNC
- P.18 CWB-9126A-CNC / CWB-9126AV-CNC
- P.19 CWB-1012A-CNC / CWB-1012AV-CNC
- P.20 CWB-1215A-CNC / CWB-1215AV-CNC
- P.21 CWG-1216AV-CNC / CWG-1516AV-CNC
- P.22 CWG-1525AV-CNC

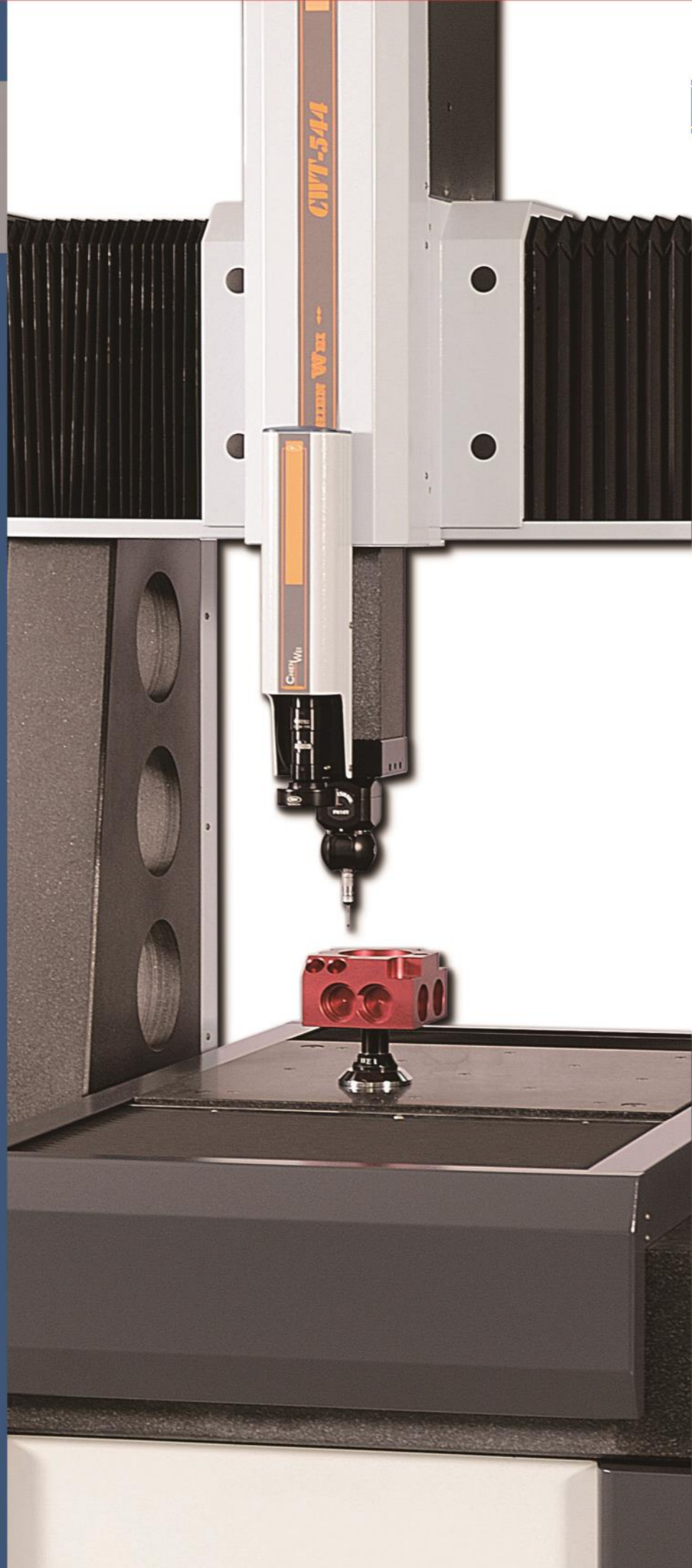

UCC 介紹

運用 Renishaw UCC 控制系統，配合 PH10MQ + SP25M 測頭及 TM25 量測模組或 SM25 掃瞄模組，可做一般 3D 量測或數位式點掃描及高精密度之接觸式連續性快速掃瞄 RENSCAN DC™

UCC universal CMM Controller is a sophisticated integrated motion control system, which is available with three levels of operating capability : Touch-trigger probing, Digitizing and Full scanning capability including Renishaw's patented RENSCAN DC™.



量測運用
SP25M taking
points with a
TP20 module

掃瞄運用
SP25M scanning



MCU 1



SPA 2



UCC2





測頭運用及分解 PROBE SYSTEMS AND STYLI

非接觸影像系統選購介紹 NON CONTACT VISION OPTIONS

測頭分解圖
PROBES EXTENSIONS
AND STYLI FOR PH10T

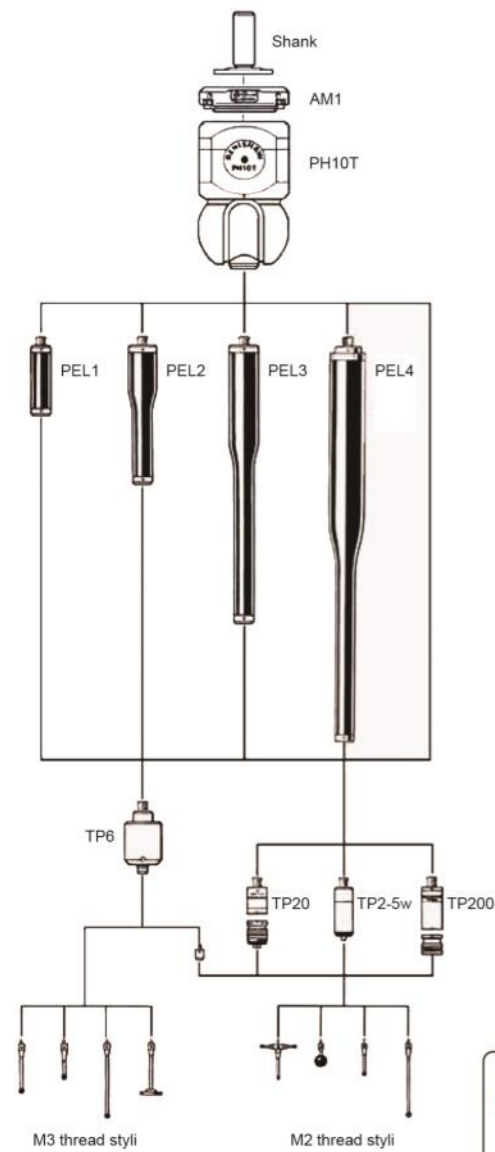

測頭運用
OPTION OF PROBES

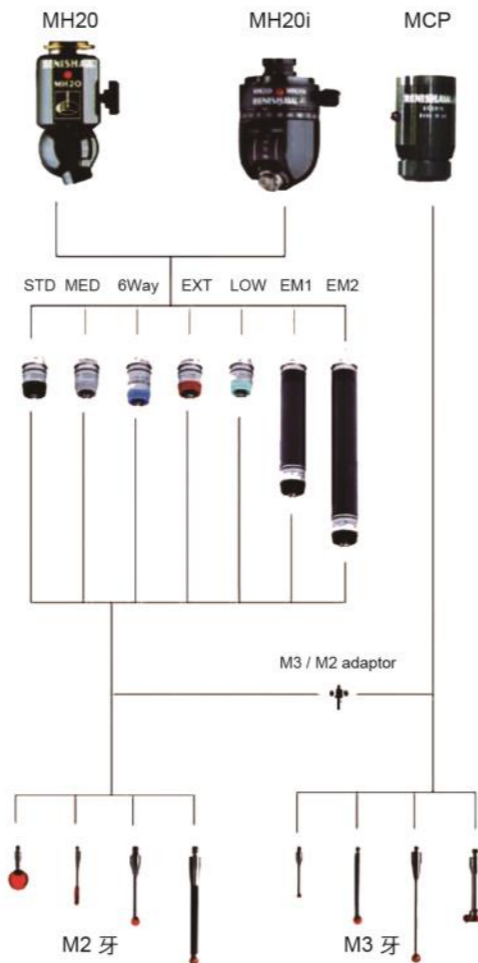

Modules / 測頭模組	Trigger force X Y	Color	Z	Styli max.
STD : Standard force 標準測力	8 gf	black	75 gf	10~40mm
MED : Medium force 中測力	10 gf	grey	190 gf	30~60mm
6-way : 6way module 六維	14 gf	blue	160 gf	10~30mm
*EXT : Extended force 高測力	10 gf	red	320 gf	30~60mm
*LOW : Low force 低測力	5.5 gf	green	65 gf	10~30mm
EM1 : Extension module 加長模組50	8 gf	marble	75 gf	10~50mm
EM2 : Extension module 加長模組75	8 gf	marble	75 gf	10~50mm

雷射影像

整合雷射裝置與影像系統，為高精密之快速對焦取像單一工具。除保有原2D影像量測之功能外，利用雷射原理使對焦速度快一倍；並提高Z軸深淺 / 厚度之量測精度，且可做非接觸之點群雷射掃描。



Laser zoom

A rapid focusing device is combined with the Laser and Vision Zoom. It increases the speed as well as the accuracy in focusing, besides the 2D vision measurement and 3D Laser scan.

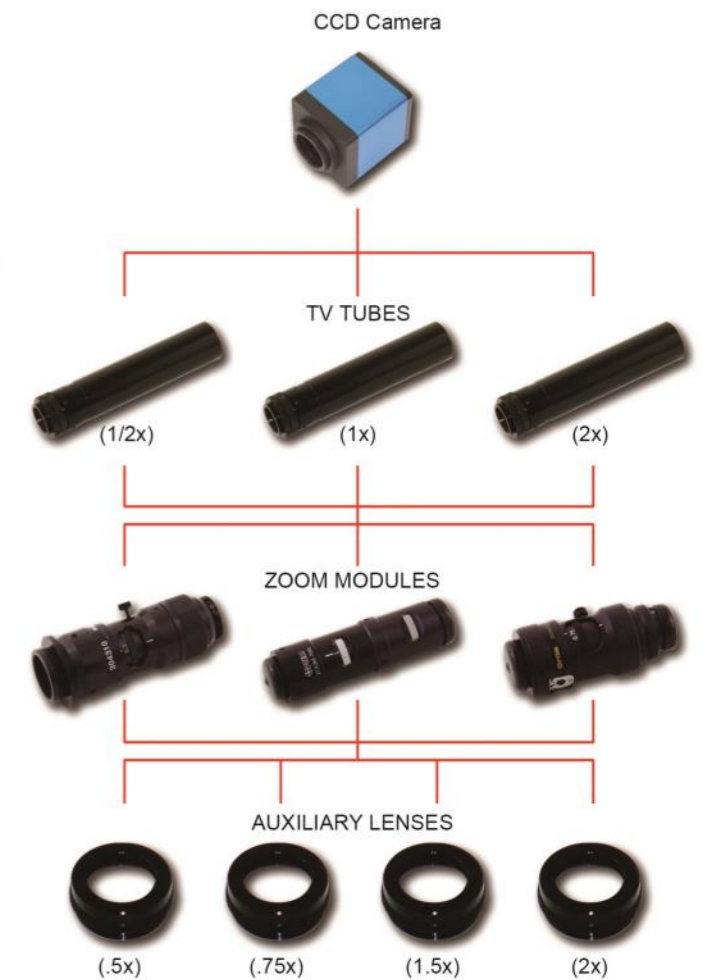

測針更換架 MCR 20

量測軟體介紹

MSU3D-PRO是一款真正的3D複合式軟體，研發團隊累積了多年專業量測軟體更集合了CAD導入，及時數據比對，報表格式多樣化，演算法先進等特點

MSU3d-PRO is professional 3D metrology software which included CAD input, measured data comparison, data output, and advanced algorithm

CAD模組導入比對功能：

CAD module input for comparison:

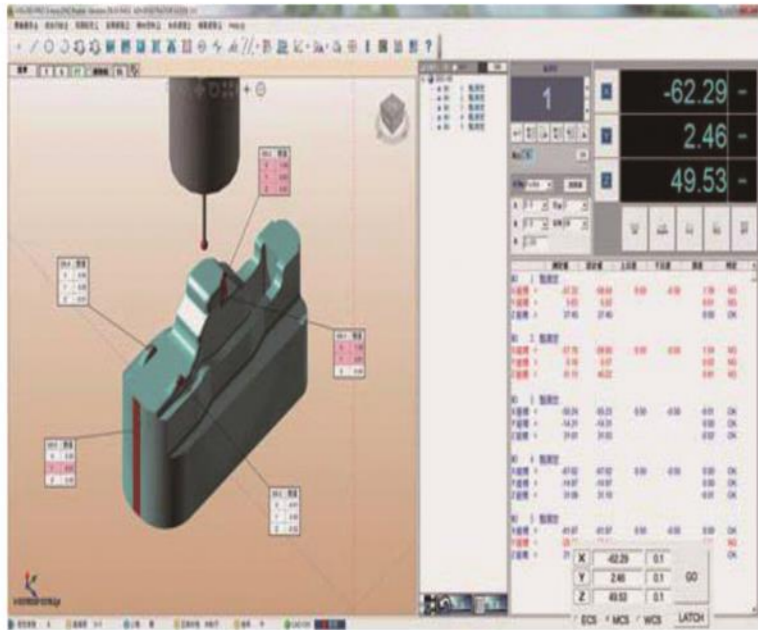

點擊模型量測：

Measuring to click on mold:

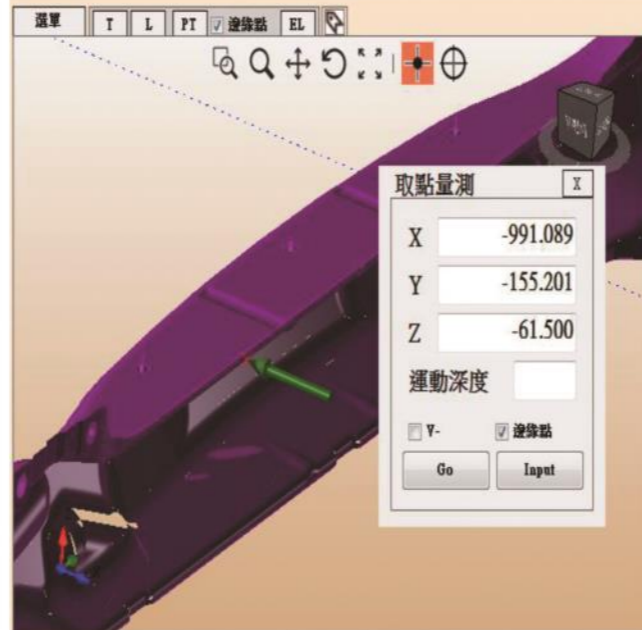

操作簡單功能強大，全圖形化顯示，快速點及操作，將CAD比對、測頭和影像完美結合的一款全新複合式量測軟體

Operate easier with strong function support. Fully graphic display, CAD comparison, probe and image measurement unity as one creative complexed metrological software.

影像、測頭及雷射共座標：

CCD, probe and laser are compatible

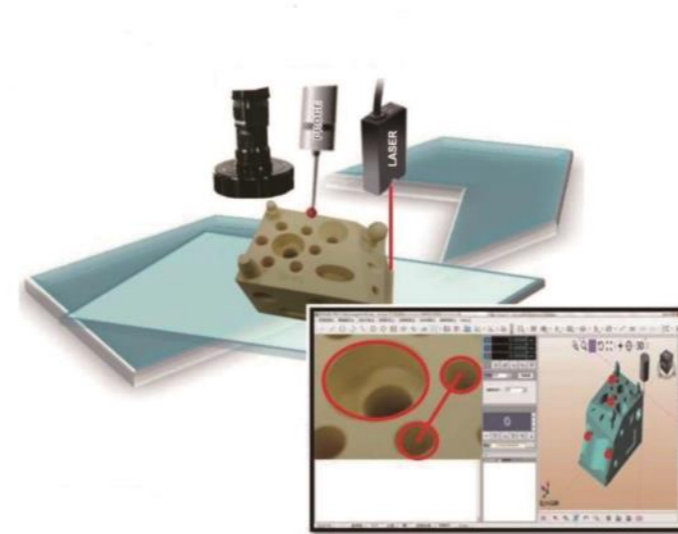

LOOP巨集複製功能：

Loop marco function:

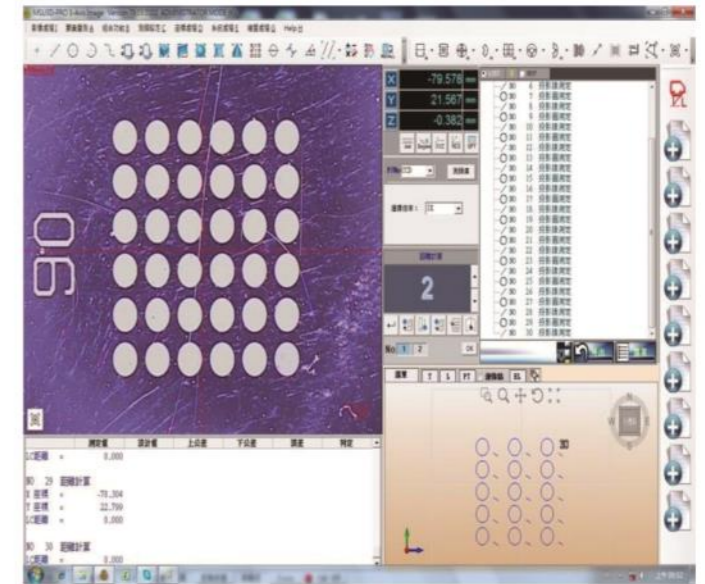

離線編程功能：

Off-Line programing:

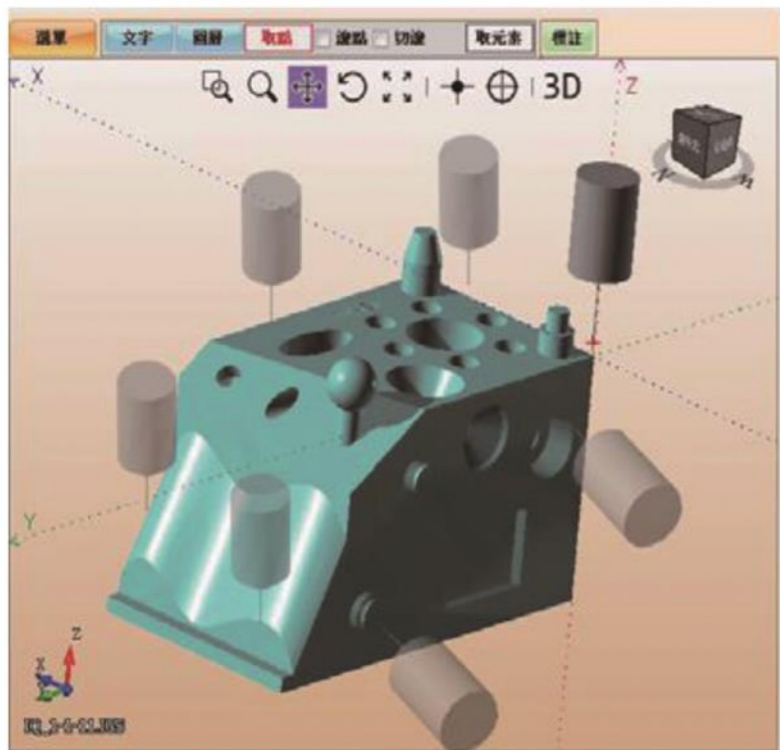

圖形導航功能：

Graphic Navigation:

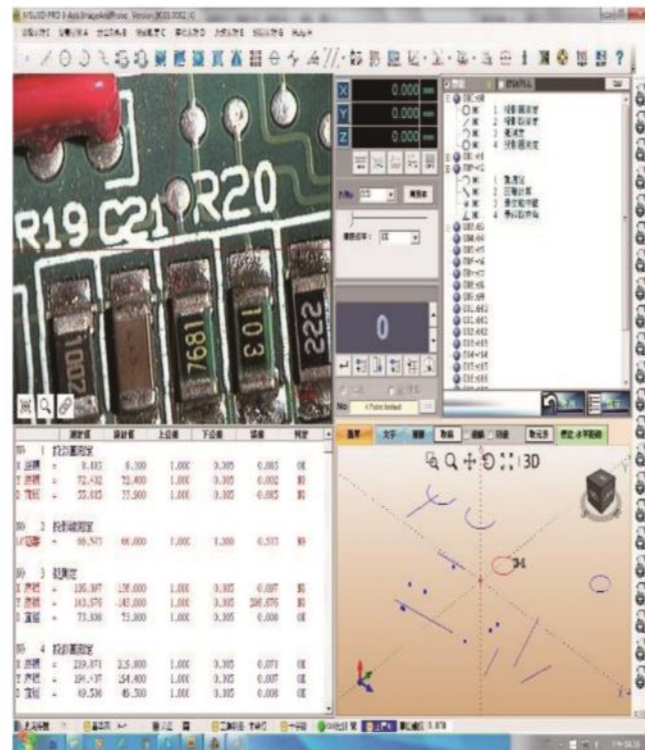

MSU3D-TWIN雙PC配對量測：

MSU-TWIN PC measuring operation:



WINQC品管資料處理軟體：

WINQC quality record and data processing :

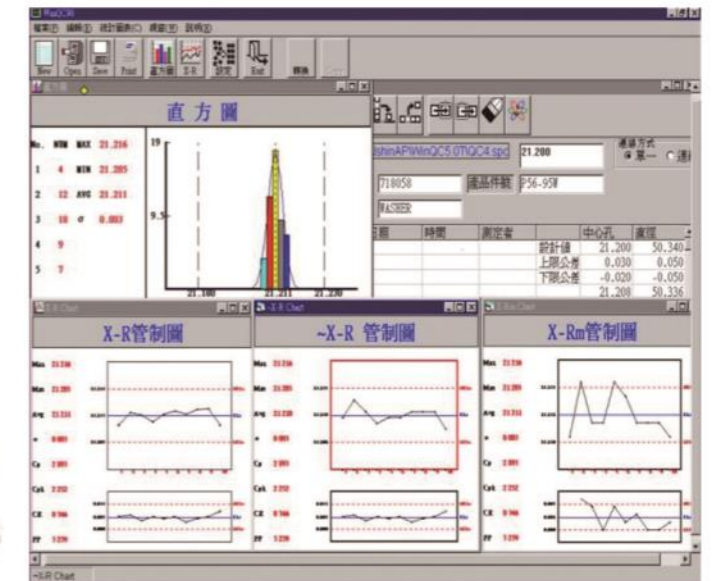

量測軟體介紹

AAT-CAPPS是一套圖形化，隨點即量之高階三次元量測軟體，可進行圖形化原點擺正，離線模擬，圓管量測，曲面掃描，數據統計SPC規劃，自動量測時碰撞迴避。

The Click-N-Measure CAD based inspection effect the CAD Alignment Off-Line Simulation Probe Collision Avoidance Free From Scanning..and so on functions of intelligent measurement.

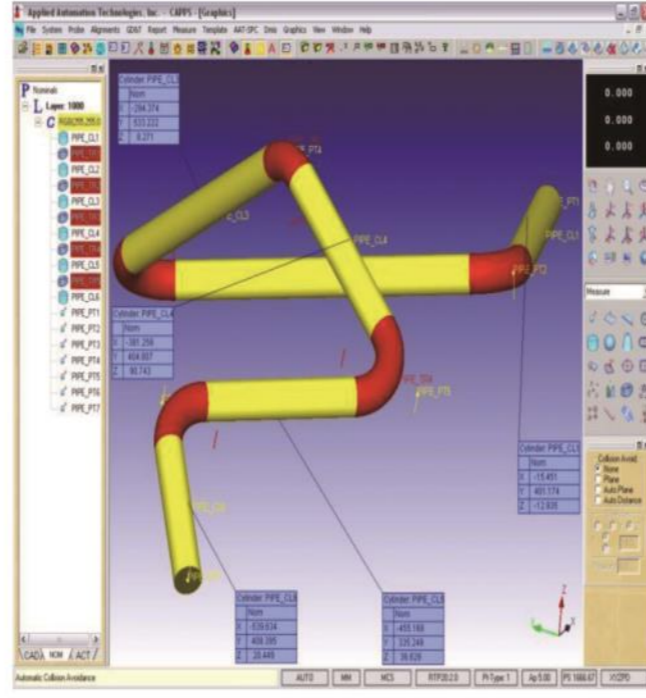
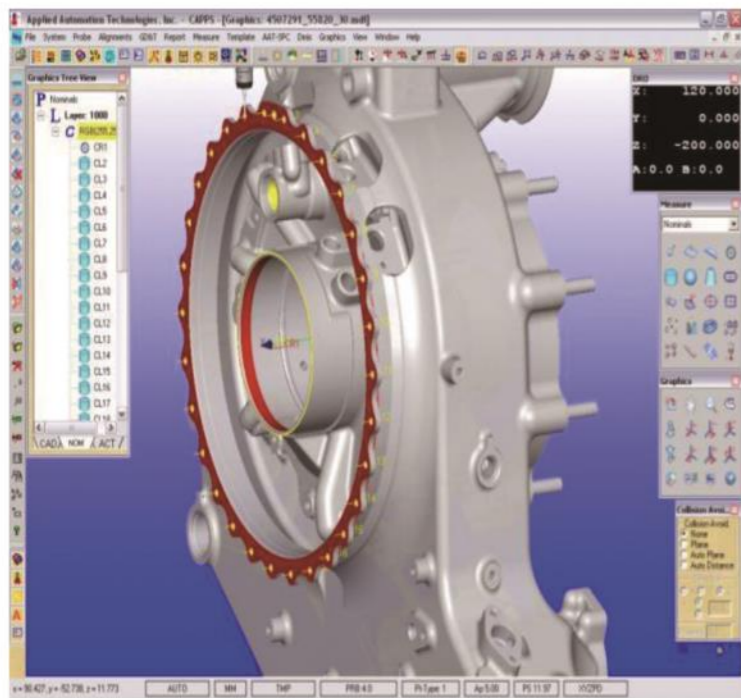

SPC : 3.txt COL:3
 XBar: 38.860
 Minimum Val: 38.858
 Maximum Val: 38.862
 CP: 4.813
 CpK: 4.768
 Sigma Capability: 0.001
 PP: 3.590
 PpK: 3.557
 Nominal: 38.860

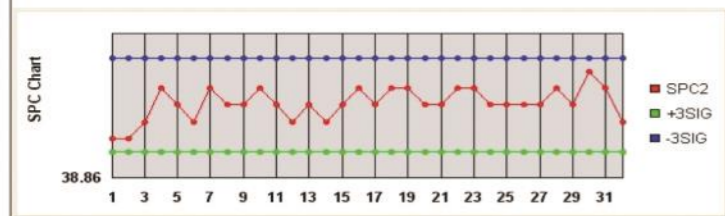

ELEM#	NOMINAL	ACTUAL	LOW_TOL	UPP_TOL	DEV	OUT_OF_TOL	CO
SPC : 3.txt COL:3							

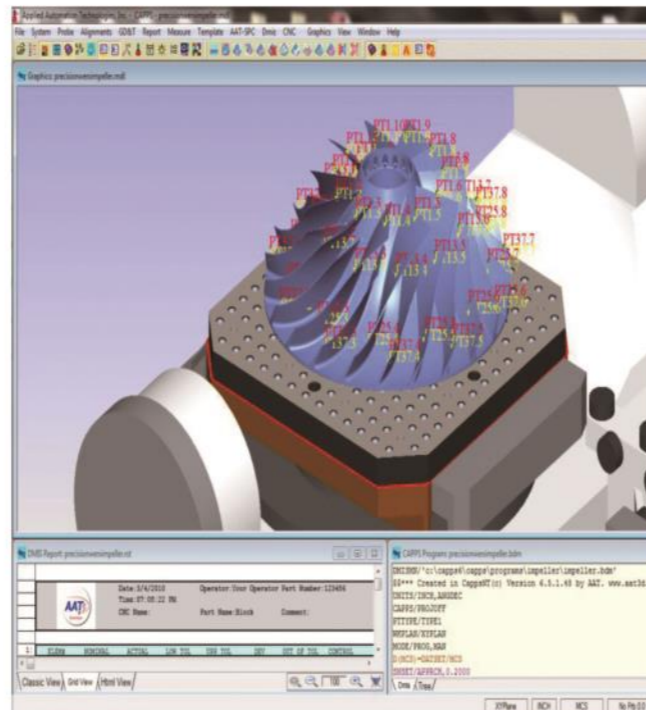
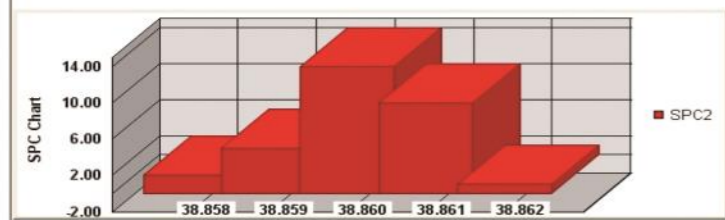

ZEPHYR II 3D 雷射頭

ZEPHYR II blue 適用於

1. 快速且準確的 3D 掃描
2. 幾何 (工件尺寸) 檢驗
3. 渦輪葉片的檢驗
4. 間隙及段差檢驗
5. 橡膠及塑膠件檢驗
6. 機械零件的幾何尺寸檢驗
7. 模具檢驗

ZEPHYR II blue 規格

1. 雷射線長度 :70mm
2. 最大回置光點數 250,000 點 / 秒
3. 最大速度 :500,000 點 / 秒 (可達 500HZ)
4. 線解析度 : 50 UM
5. 量測間距 :75MM
6. 量測 / 視覺範圍 (Measuring Field/ Field of View): 75mm
7. 精度 (再現性, 根據 OSIS/ WG3-09/2003): 10UM
8. 標準測頭系統誤差: (MPEp 標準, 根據 EN/ISO10360-2 標準):10UM
9. 多重探針測試誤差 (MPEAL; 根據 EN/ISO10360-5 或 VDI2617 6.2 章節):15UM
10. AQC (自動品質檢驗): 有
11. 溫度補償性: 有
12. 雷射: 2M 級, 藍色
13. 電腦連接性: USB
14. 機械介面: 機械手臂式, CNC 自動機械, 手動式驅動量測儀
15. Renishaw 相容性 :MIH, PH10T, PH-10M/MQ multiwire and IS1-2
16. 測頭相容性: TP2/20/200

ZEPHYR II blue is used for :

1. Fast and accurate 3D scanning
2. Geometric features inspection
3. Turbine blade inspection
4. Gap% Flush inspection
5. Rubber and plastic parts inspection
6. GD&T of mechanical parts
7. Tools and Dies inspection

ZEPHYR II blue specification

1. Laser line length : 70mm
2. Max. acquisition rate: 250,000 pts/s
3. Speed : up to 500 Hz
4. Line resolution : 50 um
5. Standoff distance: 75mm
6. Measuring field / Field of view: 75mm
7. Accuracy ; Reproducibility according to OSIS/ WG3-09/2003: 10um
8. Typical probing error (MPEp, according to EN/ISO10360-2) :10um
9. Multi stylus test accuracy (MPEAL) according to : EN/ISO10360-5 or VDI2617 part 6.2: 15um
10. AQC: yes
11. Temperature compensation : yes
12. Laser: Blue ; class 2M
13. PC communication: USB
14. Machine interface: articulated arms, CNC machine tool, manual and driven CMM
15. Renishaw compatibility : :MIH, PH10T, PH-10M/MQ multiwire and IS1-2
16. Probe compatibility under scanner: TP2/20/200



ZEPHYR II



ZEPHYR II blue

CWB-450



CWB-450V



CWB-450-CNC

規格 SPECIFICATION	CWB-450	CWB-450V	規格 SPECIFICATION	CWB-450-CNC	CWB-450V-CNC
量測行程 MEASURING TRAVEL	400 x 430 x 350 mm (X , Y , Z)	400 x 430 x 350 mm (X , Y , Z)	量測行程 MEASURING TRAVEL	400 x 430 x 350 mm (X , Y , Z)	400 x 430 x 350 mm (X , Y , Z)
解析讀數 RESOLUTION	RENISHAW Linear Scales 0.001 mm	RENISHAW Linear Scales 0.001 mm	解析讀數 RESOLUTION	RENISHAW Linear Scales 0.001 mm	RENISHAW Linear Scales 0.001 mm
量測軟體 SOFTWARE	MSD-3D Pro + WIN10	MSD-3D Pro + WIN10	量測軟體 SOFTWARE	MSD-3D Pro + WIN10	MSD-3D Pro + WIN10
電腦 HARDWARE	PC + 24" LCD Color Monitor	PC + 24" LCD Color Monitor	電腦 HARDWARE	PC + 24" LCD Color Monitor	PC + 24" LCD Color Monitor
影像系統 NON-CONTACTVISION		Color CCD + ZOOM	影像系統 NON-CONTACTVISION		Color CCD + ZOOM
放大倍率 ZOOM magnification		20X ~ 200X	放大倍率 ZOOM magnification		20X ~ 200X
表面燈源 SURFACE LIGHT		WHITE LED 白色 LED	表面燈源 SURFACE LIGHT		WHITE LED 白色 LED
Z 軸自動對焦 AUTO-FOCUS			Z 軸自動對焦 AUTO-FOCUS		Z AXIS
接觸式測頭 TRIGGER PROBE	RENISHAW MCP or MH20i (option)	RENISHAW MCP or MH20i (option)	接觸式測頭 TRIGGER PROBE	RENISHAW MH20i	RENISHAW MH20i
Z 軸配重平衡 Z AXIS BALANCE	COUNTER WEIGHT	COUNTER WEIGHT	Z 軸配重平衡 Z AXIS BALANCE	COUNTER WEIGHT	COUNTER WEIGHT
操作方式 OPERATION	MANUAL 手動	MANUAL 手動	操作方式 OPERATION	CNC PROGRAMABLE CNC 程式控制	CNC PROGRAMABLE CNC 程式控制
驅動方式 DRIVE			驅動方式 DRIVE	SERVO MOTORS + JOYSTICK 伺服馬達 + 搖桿控制	
傳動方式 TRANSMISSION	Linear Guide-Way + Drive Nut 線性滑軌 + 無牙螺桿		傳動方式 TRANSMISSION	Linear Guide-Way + Drive Nut 線性滑軌 + 無牙螺桿	
精度 ACCURACY	U1 = 2 + L / 200 um ; U3 = 4 + L / 100 um (Temperature 溫度 20° c ± 1) Humidity 相對溼度 : 55 ~ 65 %		精度 ACCURACY	U1 = 2 + L / 200 um ; U3 = 4 + L / 100 um (Temperature 溫度 20° c ± 1) Humidity 相對溼度 : 55 ~ 65 %	
花崗石平台 GRANITE PLATES	DIN.876, 0 GRADE (AREA 590 x 850 mm 放置面積)	DIN.876, 0 GRADE (AREA 590 x 850 mm 放置面積)	花崗石平台 GRANITE PLATES	DIN.876, 0 GRADE (AREA 590 x 850 mm 放置面積)	DIN.876, 0 GRADE (AREA 590 x 850 mm 放置面積)
工件限高 DEMO-PARTS HEIGHT	350 mm	350 mm	工件限高 DEMO-PARTS HEIGHT	350 mm	350 mm
工作限重 DEMO-PARTS WEIGHT	120 kgs	120 kgs	工作限重 DEMO-PARTS WEIGHT	120 kgs	120 kgs
機器尺寸 MACHINE DIMENSIONS	92 x 97 x 210 cm (Including STAND FRAME)	92 x 97 x 210 cm (Including STAND FRAME)	機器尺寸 MACHINE DIMENSIONS	92 x 97 x 210 cm (Including STAND FRAME)	92 x 97 x 210 cm (Including STAND FRAME)
外觀尺寸 (W x D x H) APPEARANCE	192 x 97 x 210 cm (Including PC TABLE)	192 x 97 x 210 cm (Including PC TABLE)	外觀尺寸 (W x D x H) APPEARANCE	212 x 97 x 210 cm (Including DELUXE TABLE)	212 x 97 x 210 cm (Including DELUXE TABLE)
機器重量 (W x D x H) MACHINE WEIGHT	570 kgs	590 kgs	機器重量 (W x D x H) MACHINE WEIGHT	600 kgs	620 kgs
選購配備 / 選購軟體 OPTION / SOFTWARE			選購配備 / 選購軟體 OPTION / SOFTWARE	AAT software	自動倍率 Auto-Zoom / 自動調光 Auto-Light / Laser-Zoom

CWB-450



CWB-450DV

CWB-554



CWB-554AV-CNC

規格 SPECIFICATION	CWB-450DV	CWB-450DV-CNC	規格 SPECIFICATION	CWB-554AV	CWB-554AV-CNC
量測行程 MEASURING TRAVEL	Probe : 400 x 380 x 280 mm (X , Y , Z) Vision : 400 x 430 x 280 mm (X , Y , Z)	Probe : 400 x 380 x 280 mm (X , Y , Z) Vision : 400 x 430 x 280 mm (X , Y , Z)	量測行程 MEASURING TRAVEL	500 x 500 x 400 mm (X , Y , Z)	500 x 500 x 400 mm (X , Y , Z)
解析讀數 RESOLUTION	RENISHAW Linear Scales 0.001 mm	RENISHAW Linear Scales 0.001 mm	解析讀數 RESOLUTION	RENISHAW Linear Scales 0.001 mm	RENISHAW Linear Scales 0.001 mm
量測軟體 SOFTWARE	MSD-3D Pro + WIN10	MSD-3D Pro + WIN10	量測軟體 SOFTWARE	MSD-3D Pro + WIN10	MSD-3D Pro + WIN10
電腦 HARDWARE	PC + 24" LCD Color Monitor	PC + 24" LCD Color Monitor	電腦 HARDWARE	PC + 24" LCD Color Monitor	PC + 24" LCD Color Monitor
影像系統 NON-CONTACTVISION	Color CCD + ZOOM	Color CCD + ZOOM	影像系統 NON-CONTACTVISION	Color CCD + ZOOM	Color CCD + ZOOM
放大倍率 ZOOM magnification	20X ~ 200X	20X ~ 200X	放大倍率 ZOOM magnification	20X ~ 200X	20X ~ 200X
表面燈源 SURFACE LIGHT	WHITE LED 白色 LED	WHITE LED 白色 LED	表面燈源 SURFACE LIGHT	WHITE LED 白色 LED	WHITE LED 白色 LED
補光底燈 CONTOUR LIGHT	GREEN LED 綠色 LED	GREEN LED 綠色 LED	Z 軸自動對焦 AUTO-FOCUS		Z AXIS
Z 軸自動對焦 AUTO-FOCUS		Z AXIS	接觸式測頭 TRIGGER PROBE	RENISHAW MCP or MH20i (option)	RENISHAW MH20i
接觸式測頭 TRIGGER PROBE	RENISHAW MCP or MH20i (option)	RENISHAW MH20i	Z 軸配重平衡 Z AXIS BALANCE		CYLINDER 氣壓缸
Z 軸配重平衡 Z AXIS BALANCE	COUNTER WEIGHT	COUNTER WEIGHT	操作方式 OPERATION	MANUAL 手動	CNC PROGRAMABLE CNC 程式控制
操作方式 OPERATION	MANUAL 手動	CNC PROGRAMABLE CNC 程式控制	驅動方式 DRIVE		SERVO MOTORS + JOYSTICK 伺服馬達 + 搖桿控制
驅動方式 DRIVE		SERVO MOTORS + JOYSTICK 伺服馬達 + 搖桿控制	傳動方式 TRANSMISSION		Air Bearing in 3 Axes (85 psi ; 0.6 Mpa more is requested)
傳動方式 TRANSMISSION	Linear Guide-Way + Drive Nut 線性滑軌 + 無牙螺桿		精度 ACCURACY	U1 = 1.5 + L / 200 um ; U3 = 3 + L / 200 um (Temperature 溫度 20° c ± 1) Humidity 相對溼度 : 55 ~ 65 %	
精度 ACCURACY	U1 = 2 + L / 200 um ; U3 = 4 + L / 100 um (Temperature 溫度 20° c ± 1) Humidity 相對溼度 : 55 ~ 65 %		花崗石平台 GRANITE PLATES	DIN.876, 0 GRADE (AREA 715 x 1000 mm 放置面積)	
花崗石平台 GRANITE PLATES	DIN.876, 0 GRADE (AREA 520 x 520 mm 放置面積)	DIN.876, 0 GRADE (AREA 520 x 520 mm 放置面積)	工件限高 DEMO-PARTS HEIGHT	400 mm	400 mm
工件限高 DEMO-PARTS HEIGHT	250 mm	250 mm	工作限重 DEMO-PARTS WEIGHT	150 kgs	150 kgs
工作限重 DEMO-PARTS WEIGHT	30 kgs	30 kgs	機器尺寸 MACHINE DIMENSIONS	111 x 123 x 236 cm (Including STAND FRAME)	111 x 123 x 236 cm (Including STAND FRAME)
機器尺寸 MACHINE DIMENSIONS	92 x 97 x 210 cm (Including STAND FRAME)	92 x 97 x 210 cm (Including STAND FRAME)	外觀尺寸 (W x D x H) APPEARANCE	211 x 123 x 236 cm (Including PC TABLE)	211 x 123 x 236 cm (Including DELUXE TABLE)
外觀尺寸 (W x D x H) APPEARANCE	192 x 97 x 210 cm (Including PC TABLE)	212 x 97 x 210 cm (Including DELUXE TABLE)	機器重量 (W x D x H) MACHINE WEIGHT	980 kgs	1000 kgs
機器重量 (W x D x H) MACHINE WEIGHT	620 kgs	640 kgs	選購配備 / 選購軟體 OPTION / SOFTWARE		自動倍率 Auto-Zoom / 自動調光 Auto-Light / Laser-Zoom AAT software / PH10T + TP20 CNC 測頭 / Programmable Probe
選購配備 / 選購軟體 OPTION / SOFTWARE		自動倍率 Auto-Zoom / 自動調光 Auto-Light / Laser-Zoom			

CWB-775



CWB-775AV



CWB-775AV-CNC

規格 SPECIFICATION	CWB-775A	CWB-775AV	規格 SPECIFICATION	CWB-775A-CNC	CWB-775AV-CNC
量測行程 MEASURING TRAVEL	700 x 700 x 500 mm (X , Y , Z)	700 x 700 x 500 mm (X , Y , Z)	量測行程 MEASURING TRAVEL	700 x 700 x 500 mm (X , Y , Z)	700 x 700 x 500 mm (X , Y , Z)
解析讀數 RESOLUTION	RENISHAW Linear Scales 0.001 mm	RENISHAW Linear Scales 0.001 mm	解析讀數 RESOLUTION	RENISHAW Linear Scales 0.001 mm	RENISHAW Linear Scales 0.001 mm
量測軟體 SOFTWARE	MSD-3D Pro + WIN10	MSD-3D Pro + WIN10	量測軟體 SOFTWARE	MSD-3D Pro + WIN10	MSD-3D Pro + WIN10
電腦 HARDWARE	PC + 24" LCD Color Monitor	PC + 24" LCD Color Monitor	電腦 HARDWARE	PC + 24" LCD Color Monitor	PC + 24" LCD Color Monitor
影像系統 NON-CONTACTVISION		Color CCD + ZOOM	影像系統 NON-CONTACTVISION		Color CCD + ZOOM
放大倍率 ZOOM magnification		20X ~ 200X	放大倍率 ZOOM magnification		20X ~ 200X
表面燈源 SURFACE LIGHT		WHITE LED 白色 LED	表面燈源 SURFACE LIGHT		WHITE LED 白色 LED
Z 軸自動對焦 AUTO-FOCUS			Z 軸自動對焦 AUTO-FOCUS		Z AXIS
接觸式測頭 TRIGGER PROBE		RENISHAW MH20i	接觸式測頭 TRIGGER PROBE		RENISHAW MH20i
Z 軸配重平衡 Z AXIS BALANCE		CYLINDER 氣壓缸	Z 軸配重平衡 Z AXIS BALANCE		CYLINDER 氣壓缸
操作方式 OPERATION		MANUAL 手動	操作方式 OPERATION		CNC PROGRAMABLE CNC 程式控制
驅動方式 DRIVE			驅動方式 DRIVE		SERVO MOTORS + JOYSTICK 伺服馬達 + 搖桿控制
傳動方式 TRANSMISSION		Air Bearing in 3 Axes (85 psi ; 0.6 Mpa more is requested)	傳動方式 TRANSMISSION		Air Bearing in 3 Axes (85 psi ; 0.6 Mpa more is requested)
精度 ACCURACY	U1 = 1.5 + L / 200 um ; U3 = 3 + L / 200 um (Temperature 溫度 20° c ± 1) Humidity 相對溼度 : 55 ~ 65 %		精度 ACCURACY	U1 = 1.5 + L / 200 um ; U3 = 3 + L / 200 um (Temperature 溫度 20° c ± 1) Humidity 相對溼度 : 55 ~ 65 %	
花崗石平台 GRANITE PLATES	DIN.876, 0 GRADE (AREA 930 x 1400 mm 放置面積)		花崗石平台 GRANITE PLATES	DIN.876, 0 GRADE (AREA 930 x 1400 mm 放置面積)	
工件限高 DEMO-PARTS HEIGHT	500 mm		工件限高 DEMO-PARTS HEIGHT	500 mm	
工作限重 DEMO-PARTS WEIGHT	200 kgs		工作限重 DEMO-PARTS WEIGHT	200 kgs	
機器尺寸 MACHINE DIMENSIONS	137 x 153 x 260 cm (Including STAND FRAME)		機器尺寸 MACHINE DIMENSIONS	137 x 153 x 260 cm (Including STAND FRAME)	
外觀尺寸 (W x D x H) APPEARANCE	237 x 153 x 260 cm (Including PC TABLE)		外觀尺寸 (W x D x H) APPEARANCE	237 x 153 x 260 cm (Including DELUXE TABLE)	
機器重量 (W x D x H) MACHINE WEIGHT	1100 kgs	1120 kgs	機器重量 (W x D x H) MACHINE WEIGHT	1150 kgs	1170 kgs
選購配備 / 選購軟體 OPTION / SOFTWARE			選購配備 / 選購軟體 OPTION / SOFTWARE	PH10T 測頭 + TP20 / Programmable Probe AAT software	自動倍率 Auto-Zoom / 自動調光 Auto-Light / Laser-Zoom

CWT-544



CWT-544AV-CNC

CWT-875



CWT-875AV-CNC

規格 SPECIFICATION	CWT-544A-CNC	CWT-544AV-CNC	規格 SPECIFICATION	CWT-875A-CNC	CWT-875AV-CNC
量測行程 MEASURING TRAVEL	500 x 400 x 400 mm (X , Y , Z)	Probe : 500 x 400 x 400 mm (X , Y , Z) Vision : 500 x 300 x 400 mm (X , Y , Z)	量測行程 MEASURING TRAVEL	800 x 650 x 500 mm (X , Y , Z)	Probe : 800 x 650 x 500 mm (X , Y , Z) Vision : 800 x 550 x 500 mm (X , Y , Z)
解析讀數 RESOLUTION	RENISHAW Linear Scales 0.0001 mm	RENISHAW Linear Scales 0.0001 mm	解析讀數 RESOLUTION	RENISHAW Linear Scales 0.0001 mm	RENISHAW Linear Scales 0.0001 mm
量測軟體 SOFTWARE	MSD-3D Pro + WIN10	MSD-3D Pro + WIN10	量測軟體 SOFTWARE	MSD-3D Pro + WIN10	MSD-3D Pro + WIN10
電腦 HARDWARE	PC + 24" LCD Color Monitor	PC + 24" LCD Color Monitor	電腦 HARDWARE	PC + 24" LCD Color Monitor	PC + 24" LCD Color Monitor
影像系統 NON-CONTACTVISION		Color CCD + ZOOM	影像系統 NON-CONTACTVISION		Color CCD + ZOOM
放大倍率 ZOOM magnification		20X ~ 200X	放大倍率 ZOOM magnification		20X ~ 200X
表面燈源 SURFACE LIGHT		WHITE LED 白色 LED	表面燈源 SURFACE LIGHT		WHITE LED 白色 LED
Z 軸自動對焦 AUTO-FOCUS		Z AXIS	Z 軸自動對焦 AUTO-FOCUS		Z AXIS
接觸式測頭 TRIGGER PROBE		RENISHAW PH10T	接觸式測頭 TRIGGER PROBE		RENISHAW PH10T
Z 軸配重平衡 Z AXIS BALANCE		CYLINDER 氣壓缸	Z 軸配重平衡 Z AXIS BALANCE		CYLINDER 氣壓缸
操作方式 OPERATION	CNC PROGRAMABLE CNC 程式控制		操作方式 OPERATION	CNC PROGRAMABLE CNC 程式控制	
驅動方式 DRIVE	SERVO MOTORS + JOYSTICK 伺服馬達 + 搖桿控制		驅動方式 DRIVE	SERVO MOTORS + JOYSTICK 伺服馬達 + 搖桿控制	
傳動方式 TRANSMISSION	Air Bearing in 3 Axes (85 psi ; 0.6 Mpa more is requested)		傳動方式 TRANSMISSION	Air Bearing in 3 Axes (85 psi ; 0.6 Mpa more is requested)	
精度 ACCURACY	U1 = 0.5 + L / 400 um ; U3 = 1.9 + L / 300 um (Temperature 溫度 20°c ± 1) Humidity 相對溼度 : 55 ~ 65 %		精度 ACCURACY	U1 = 0.5 + L / 400 um ; U3 = 1.9 + L / 300 um (Temperature 溫度 20°c ± 1) Humidity 相對溼度 : 55 ~ 65 %	
花崗石平台 GRANITE PLATES	DIN.876, 0 GRADE (AREA 400 x 500 mm 放置面積)		花崗石平台 GRANITE PLATES	DIN.876, 0 GRADE (AREA 860 x 700 mm 放置面積)	
工件限高 DEMO-PARTS HEIGHT	400 mm		工件限高 DEMO-PARTS HEIGHT	500 mm	
工作限重 DEMO-PARTS WEIGHT	80 kgs		工作限重 DEMO-PARTS WEIGHT	160 kgs	
機器尺寸 MACHINE DIMENSIONS	110 x 120 x 255 cm (Including STAND FRAME)		機器尺寸 MACHINE DIMENSIONS	160 x 180 x 283 cm (Including STAND FRAME)	
外觀尺寸 (W x D x H) APPEARANCE	205 x 120 x 255 cm (Including DELUXE TABLE)		外觀尺寸 (W x D x H) APPEARANCE	244 x 180 x 283 cm (Including DELUXE TABLE)	
機器重量 (W x D x H) MACHINE WEIGHT	1200 kgs	1220 kgs	機器重量 (W x D x H) MACHINE WEIGHT	1800 kgs	1820 kgs
選購配備 / 選購軟體 OPTION / SOFTWARE	AAT software		選購配備 / 選購軟體 OPTION / SOFTWARE	AAT software / 自動倍率 Auto-Zoom / 自動調光 Auto-Light	

CWT-1000



CWT-1000AV-CNC

CWB-9126



CWB-9126A-CNC

規格 SPECIFICATION	CWT-1000A-CNC	CWT-1000AV-CNC	規格 SPECIFICATION	CWB-9126A-CNC	CWB-9126AV-CNC
量測行程 MEASURING TRAVEL	400 x 1000 x 300 mm (X , Y , Z)	Probe : 400 x 1000 x 300 mm (X , Y , Z) Vision : 400 x 900 x 300 mm (X , Y , Z)	量測行程 MEASURING TRAVEL	900 x 1200 x 600 mm (X , Y , Z)	900 x 1200 x 600 mm (X , Y , Z)
解析讀數 RESOLUTION	RENISHAW Linear Scales 0.0001 mm	RENISHAW Linear Scales 0.0001 mm	解析讀數 RESOLUTION	RENISHAW Linear Scales 0.001 mm	RENISHAW Linear Scales 0.001 mm
量測軟體 SOFTWARE	MSD-3D Pro + WIN10	MSD-3D Pro + WIN10	量測軟體 SOFTWARE	MSD-3D Pro + WIN10	MSD-3D Pro + WIN10
電腦 HARDWARE	PC + 24" LCD Color Monitor	PC + 24" LCD Color Monitor	電腦 HARDWARE	PC + 24" LCD Color Monitor	PC + 24" LCD Color Monitor
影像系統 NON-CONTACTVISION		Color CCD + ZOOM	影像系統 NON-CONTACTVISION		Color CCD + ZOOM
放大倍率 ZOOM magnification		20X ~ 200X	放大倍率 ZOOM magnification		20X ~ 200X
表面燈源 SURFACE LIGHT		WHITE LED 白色 LED	表面燈源 SURFACE LIGHT		WHITE LED 白色 LED
Z 軸自動對焦 AUTO-FOCUS		Z AXIS	Z 軸自動對焦 AUTO-FOCUS		Z AXIS
接觸式測頭 TRIGGER PROBE		RENISHAW PH10T	接觸式測頭 TRIGGER PROBE		RENISHAW MH20i
Z 軸配重平衡 Z AXIS BALANCE		CYLINDER 氣壓缸	Z 軸配重平衡 Z AXIS BALANCE		CYLINDER 氣壓缸
操作方式 OPERATION		CNC PROGRAMABLE CNC 程式控制	操作方式 OPERATION		CNC PROGRAMABLE CNC 程式控制
驅動方式 DRIVE		SERVO MOTORS + JOYSTICK 伺服馬達 + 搖桿控制	驅動方式 DRIVE		SERVO MOTORS + JOYSTICK 伺服馬達 + 搖桿控制
傳動方式 TRANSMISSION		Air Bearing in 3 Axes (85 psi ; 0.6 Mpa more is requested)	傳動方式 TRANSMISSION		Air Bearing in 3 Axes (85 psi ; 0.6 Mpa more is requested)
精度 ACCURACY	U1 = 0.5 + L / 400 um ; U3 = 1.9 + L / 300 um (Temperature 溫度 20°c ± 1) Humidity 相對溼度 : 55 ~ 65 %		精度 ACCURACY	U1 = 1.5 + L / 200 um ; U3 = 4 + L / 150 um (Temperature 溫度 20°c ± 1) Humidity 相對溼度 : 55 ~ 65 %	
花崗石平台 GRANITE PLATES		DIN.876, 0 GRADE (AREA 400 x 500 mm 放置面積)	花崗石平台 GRANITE PLATES		DIN.876, 0 GRADE (AREA 1100 x 1800 mm 放置面積)
工件限高 DEMO-PARTS HEIGHT		300 mm	工件限高 DEMO-PARTS HEIGHT		600 mm
工作限重 DEMO-PARTS WEIGHT		100 kgs	工作限重 DEMO-PARTS WEIGHT		800 kgs
機器尺寸 MACHINE DIMENSIONS		110 x 210 x 234 cm (Including STAND FRAME)	機器尺寸 MACHINE DIMENSIONS		172 x 231 x 290 cm (Including STAND FRAME)
外觀尺寸 (W x D x H) APPEARANCE		204 x 210 x 234 cm (Including DELUXE TABLE)	外觀尺寸 (W x D x H) APPEARANCE		290 x 231 x 290 cm (Including DELUXE TABLE)
機器重量 (W x D x H) MACHINE WEIGHT	1600 kgs	1620 kgs	機器重量 (W x D x H) MACHINE WEIGHT	2950 kgs	2970 kgs
選購配備 / 選購軟體 OPTION / SOFTWARE		AAT software / 自動倍率 Auto-Zoom / 自動調光 Auto-Light	選購配備 / 選購軟體 OPTION / SOFTWARE	AAT software / 自動倍率 Auto-Zoom / 自動調光 Auto-Light ; PH10T 測頭 / Programmable Probe	

CWB-9128



CWB-1215



規格 SPECIFICATION	CWB-9128A-CNC	CWB-9128AV-CNC
量測行程 MEASURING TRAVEL	900 x 1200 x 800 mm (X , Y , Z)	900 x 1200 x 800 mm (X , Y , Z)
解析讀數 RESOLUTION	RENISHAW Linear Scales 0.001 mm	RENISHAW Linear Scales 0.001 mm
量測軟體 SOFTWARE	MSD-3D Pro + WIN10	MSD-3D Pro + WIN10
電腦 HARDWARE	PC + 24" LCD Color Monitor	PC + 24" LCD Color Monitor
影像系統 NON-CONTACTVISION		Color CCD + ZOOM
放大倍率 ZOOM magnification		20X ~ 200X
表面燈源 SURFACE LIGHT		WHITE LED 白色 LED
Z 軸自動對焦 AUTO-FOCUS		Z AXIS
接觸式測頭 TRIGGER PROBE		RENISHAW MH20i
Z 軸配重平衡 Z AXIS BALANCE		CYLINDER 氣壓缸
操作方式 OPERATION	CNC PROGRAMABLE CNC 程式控制	
驅動方式 DRIVE	SERVO MOTORS + JOYSTICK 伺服馬達 + 搖桿控制	
傳動方式 TRANSMISSION	Air Bearing in 3 Axes (85 psi ; 0.6 Mpa more is requested)	
精度 ACCURACY	U1 = 1.5 + L / 200 um ; U3 = 4 + L / 150 um (Temperature 溫度 20° c ± 1) Humidity 相對溼度 : 55 ~ 65 %	
花崗石平台 GRANITE PLATES	DIN.876, 0 GRADE (AREA 1300 x 2000 mm 放置面積)	
工件限高 DEMO-PARTS HEIGHT	600 mm	
工作限重 DEMO-PARTS WEIGHT	800 kgs	
機器尺寸 MACHINE DIMENSIONS	172 x 231 x 322 cm (Including STAND FRAME)	
外觀尺寸 (W x D x H) APPEARANCE	290 x 231 x 322 cm (Including DELUXE TABLE)	
機器重量 (W x D x H) MACHINE WEIGHT	3000 kgs	3020 kgs
選購配備 / 選購軟體 OPTION / SOFTWARE	AAT software / 自動倍率 Auto-Zoom / 自動調光 Auto-Light ; PH10T 測頭 / Programmable Probe	

規格 SPECIFICATION	CWB-1215A-CNC	CWB-1215AV-CNC
量測行程 MEASURING TRAVEL	1200 x 1500 x 600 mm (X , Y , Z)	1200 x 1500 x 600 mm (X , Y , Z)
解析讀數 RESOLUTION	RENISHAW Linear Scales 0.001 mm	RENISHAW Linear Scales 0.001 mm
量測軟體 SOFTWARE	MSD-3D Pro + WIN10	MSD-3D Pro + WIN10
電腦 HARDWARE	PC + 24" LCD Color Monitor	PC + 24" LCD Color Monitor
影像系統 NON-CONTACTVISION		Color CCD + ZOOM
放大倍率 ZOOM magnification		20X ~ 200X
表面燈源 SURFACE LIGHT		WHITE LED 白色 LED
Z 軸自動對焦 AUTO-FOCUS		Z AXIS
接觸式測頭 TRIGGER PROBE		RENISHAW PH10T
Z 軸配重平衡 Z AXIS BALANCE		CYLINDER 氣壓缸
操作方式 OPERATION	CNC PROGRAMABLE CNC 程式控制	
驅動方式 DRIVE	SERVO MOTORS + JOYSTICK 伺服馬達 + 搖桿控制	
傳動方式 TRANSMISSION	Air Bearing in 3 Axes (85 psi ; 0.6 Mpa more is requested)	
精度 ACCURACY	U1 = 2 + L / 200 um ; U3 = 4 + L / 150 um (Temperature 溫度 20° c ± 1) Humidity 相對溼度 : 55 ~ 65 %	
花崗石平台 GRANITE PLATES	DIN.876, 0 GRADE (AREA 1500 x 2200 mm 放置面積)	
工件限高 DEMO-PARTS HEIGHT	600 mm	
工作限重 DEMO-PARTS WEIGHT	800 kgs	
機器尺寸 MACHINE DIMENSIONS	220 x 255 x 302 cm (Including STAND FRAME)	
外觀尺寸 (W x D x H) APPEARANCE	340 x 255 x 302 cm (Including DELUXE TABLE)	
機器重量 (W x D x H) MACHINE WEIGHT	4800 kgs	4820 kgs
選購配備 / 選購軟體 OPTION / SOFTWARE	Z 軸可加高到 800 mm Z axis can be increased up to 800 mm AAT software / 自動倍率 Auto-Zoom / 自動調光 Auto-Light ; PH10T 測頭 / Programmable Probe	

CWG-1216



CWG-1525



規格 SPECIFICATION	CWG-1216AV-CNC	CWG-1516AV-CNC
量測行程 MEASURING TRAVEL	1200 x 1600 x 1000 mm (X , Y , Z)	1500 x 1600 x 1000 mm (X , Y , Z)
解析讀數 RESOLUTION	RENISHAW Linear Scales 0.001 mm / option 0.0001 mm	
量測軟體 SOFTWARE	MSD-3D Pro + WIN10	
電腦 HARDWARE	PC + 24" LCD Color Monitor	
影像系統 NON-CONTACTVISION	Color CCD + ZOOM	
放大倍率 ZOOM magnification	20X ~ 200X	
表面燈源 SURFACE LIGHT	WHITE LED 白色 LED	
Z 軸自動對焦 AUTO-FOCUS	Z AXIS	
接觸式測頭 TRIGGER PROBE	RENISHAW PH10T	
Z 軸配重平衡 Z AXIS BALANCE	CYLINDER 氣壓缸	
操作方式 OPERATION	CNC PROGRAMABLE CNC 程式控制	
驅動方式 DRIVE	SERVO MOTORS + JOYSTICK 伺服馬達 + 搖桿控制	
傳動方式 TRANSMISSION	Air Bearing in 3 Axes (85 psi ; 0.6 Mpa more is requested)	
精度 ACCURACY	U1 = 3 + L / 200 um ; U3 = 5 + L / 150 um (Temperature 溫度 20 ° c ± 1) Humidity 相對溼度 : 55 ~ 65 %	
花崗石平台 GRANITE PLATES	DIN.876, 0 GRADE (AREA 1800 x 2400 mm 放置面積)	DIN.876, 0 GRADE (AREA 2250 x 2200 mm 放置面積)
工件限高 DEMO-PARTS HEIGHT	900 mm	
工作限重 DEMO-PARTS WEIGHT	1200 kgs	
機器尺寸 MACHINE DIMENSIONS	265 x 295 x 345 cm (Including STAND FRAME)	295 x 295 x 345 cm (Including STAND FRAME)
外觀尺寸 (W x D x H) APPEARANCE	385 x 295 x 345 cm (Including DELUXE TABLE)	400 x 295 x 345 cm (Including DELUXE TABLE)
機器重量 (W x D x H) MACHINE WEIGHT	6500 kgs	6700 kgs
選購配備 / 選購軟體 OPTION / SOFTWARE	Z 軸可加高到 1500 mm Z axis can be increased up to 1500 mm AAT software / 自動倍率 Auto-Zoom / 自動調光 Auto-Light	

規格 SPECIFICATION	CWG-1525AV-CNC
量測行程 MEASURING TRAVEL	1500 x 2500 x 1000 mm (X , Y , Z)
解析讀數 RESOLUTION	RENISHAW Linear Scales 0.001 mm / option 0.0001 mm
量測軟體 SOFTWARE	MSD-3D Pro + WIN10
電腦 HARDWARE	PC + 24" LCD Color Monitor
影像系統 NON-CONTACTVISION	Color CCD + ZOOM
放大倍率 ZOOM magnification	20X ~ 200X
表面燈源 SURFACE LIGHT	WHITE LED 白色 LED
Z 軸自動對焦 AUTO-FOCUS	Z AXIS
接觸式測頭 TRIGGER PROBE	RENISHAW PH10T
Z 軸配重平衡 Z AXIS BALANCE	CYLINDER 氣壓缸
操作方式 OPERATION	CNC PROGRAMABLE CNC 程式控制
驅動方式 DRIVE	SERVO MOTORS + JOYSTICK 伺服馬達 + 搖桿控制
傳動方式 TRANSMISSION	Air Bearing in 3 Axes (85 psi ; 0.6 Mpa more is requested)
精度 ACCURACY	U1 = 3 + L / 200 um ; U3 = 5 + L / 150 um (Temperature 溫度 20 ° c ± 1) Humidity 相對溼度 : 55 ~ 65 %
花崗石平台 GRANITE PLATES	DIN.876, 0 GRADE (AREA 2250 x 3100 mm 放置面積)
工件限高 DEMO-PARTS HEIGHT	900 mm
工作限重 DEMO-PARTS WEIGHT	1200 kgs
機器尺寸 MACHINE DIMENSIONS	295 x 365 x 345 cm (Including STAND FRAME)
外觀尺寸 (W x D x H) APPEARANCE	400 x 365 x 345 cm (Including DELUXE TABLE)
機器重量 (W x D x H) MACHINE WEIGHT	8350 kgs
選購配備 / 選購軟體 OPTION / SOFTWARE	Z 軸可加高到 1500 mm Z axis can be increased up to 1500 mm AAT software / 自動倍率 Auto-Zoom / 自動調光 Auto-Light