

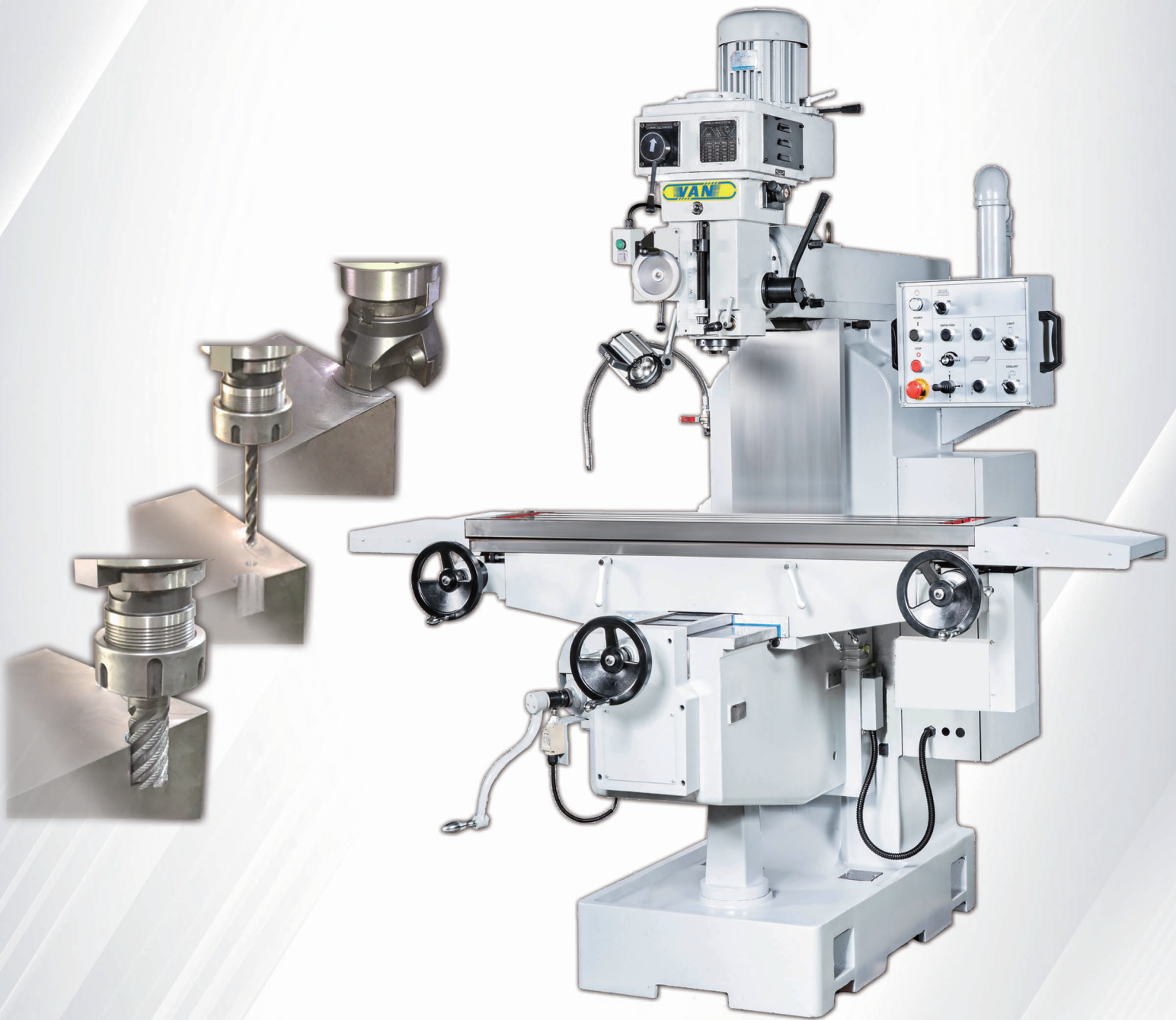

**YING SHUN
MACHINERY INDUSTRY CO., LTD.**

Vertical Turret Milling Machine

YSM-20B SERIES



MECHANICAL FEATURE

- The main casting part is made of meehanite casting.
- Milling head type:
 - Steps (BS) Inverter (BC)
- The spindle is one piece machined from SCM440 alloysteel, high-frequency and precision polishing.
- X/Y axis double nut ball screw.

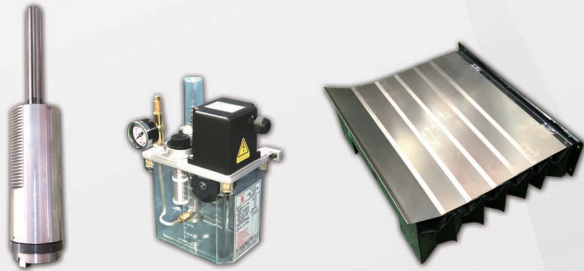

MECHANICAL DIMENSIONS

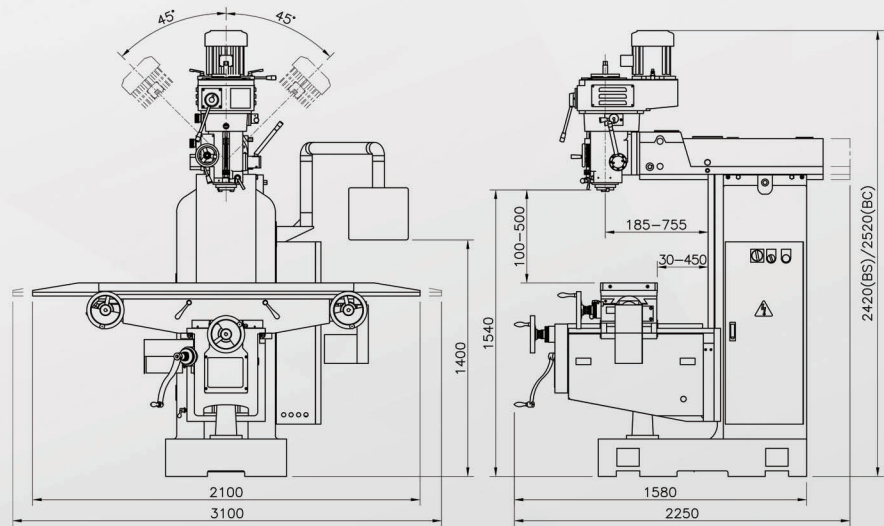

SPECIFICATONS AND ACCESSORIES

Model	Unit	20BS	20BC
Travel			
Longitudinal travel (M./A.)	mm	1000 (Opt.800)	
Cross travel (M./A.)	mm	420	
Vertical travel (M./A.)	mm	400	
Slideway X/Y/Z	type	△ / □ / □	
Quill travel	mm	140	
Overarm travel	mm	570	
Overarm swivel	degree	Fiexd	
Quill swivel (R&L)/(F&B)	degree	±45/Fiexd	
Table			
Dimension	mm	1370x300 (Opt.1270x300)	
T-slots (WidthxNo.xPitch)	mm	16x3x70	
Spindle			
Milling head	type	10 Steps	Inverter
Speed	60Hz	rpm	75-3500
	50Hz	rpm	60-2870
Vertical feeds	mm/rev	0.04/0.08/0.15	
Taper	type	NT40	
Quill Diameter	mm	110	
Motor			
Main spindle	HP	5 (Opt.7.5)	
X/Y axis traverse	HP	1	
Z axis elevation	HP	1	
feedrate			
X/Y axis speed	mm/min	0-1800	
Z axis speed	mm/min	1150	
Machine			
Net Weight	kg	2000	

Standard accessries

- Draw bar
- Tool box and tools
- Tapping equipment of spindle
- Front finned bellows cover on Y axis
- Back chip cover on Y axis
- Working lamp
- Auto lubrication system
- X/Y axis servo motor
- Z Axis Rapid up/down
- Deluxe type operation panel
- Electric box
- Ball scerw (X/Y)

Optional accessories

- Draw bar(pneumatic)
- Digital readout (DRO)
- Coolant system(Pump 1/8HP)
- Chip tray



YING SHUN MACHINERY INDUSTRY CO., LTD.

All specification , dimension and design characteristics shown in this catalogue are subject to change without notice.

No.5,Aly.162,Ln.136,Sec.1,Jiahou Rd.,Houli Dist., Taichung City 421,Taiwan(R.O.C.)

TEL:+886-4-25586346

ys@yingshun.com.tw

FAX:+886-4-25586930

https://www.yingshun.com.tw