

# MC SUB TABLE / MC TOOLING BLOCKS

## MC 精密治具板 / MC 精密治具桶

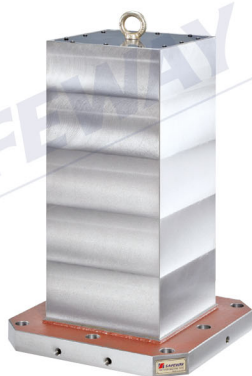

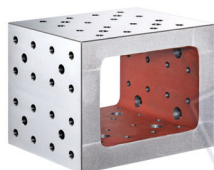
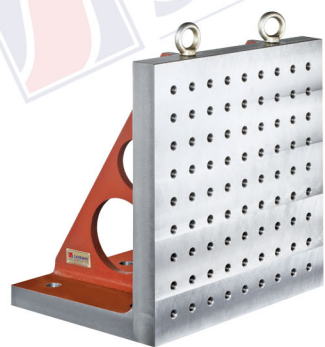

**MC SUB TABLE**  
**MC 精密治具板**



**FEATURES :**

- Both ground & paralleled within 0.010/500mm
- Material:FCD600~60kgs/mm<sup>2</sup> ductile iron (High tensile casting)
- Annealing.

※Please fill D.E.F.K.PITCH dimension of yourself.

**特性:**

- 兩面精密研磨0.010mm/500mm
- 材質：球狀石墨化鑄鐵 FCD600~60kgs/mm<sup>2</sup>
- 退火處理

※D.E.F.K間格數請客戶自行填上，並告知機械機種。

**MODEL**

- ST-300×600×70, 500×1000×75, 550×1200×75, 700×1700×80
- ST-350×800×75, 510× 850×75, 600×1200×75, 800×2300×85
- ST-400×950×75, 510×1000×75, 600×1500×80, 850×2100×85
- ST-410×900×75, 510×1200×75, 650×1600×80, 850×2300×85
- ST-450×900×75, 510×1300×75, 650×1700×80, 900×2400×85

**MODEL**

- SC-300×600×70, 500×1000×75, 550×1200×75, 700×1700×80
- SC-350×800×75, 510× 850×75, 600×1200×75, 800×2300×85
- SC-400×950×75, 510×1000×75, 600×1500×80, 850×2100×85
- SC-410×900×75, 510×1200×75, 650×1600×80, 850×2300×85
- SC-450×900×75, 510×1300×75, 650×1700×80, 900×2400×85

**MODEL**

- SH-300×600×70, 500×1000×75, 550×1200×75, 700×1700×80
- SH-350×800×75, 510× 850×75, 600×1200×75, 800×2300×85
- SH-400×950×75, 510×1000×75, 600×1500×80, 850×2100×85
- SH-410×900×75, 510×1200×75, 650×1600×80, 850×2300×85
- SH-450×900×75, 510×1300×75, 650×1700×80, 900×2400×85
- SH-340×510×30, 340× 660×30, 405× 660×35, 405× 780×35
- SH-495×720×40, 495× 940×40

※ Accept special order, T-slots as ISO.  
接受特別尺寸訂製，T型槽依ISO標準。

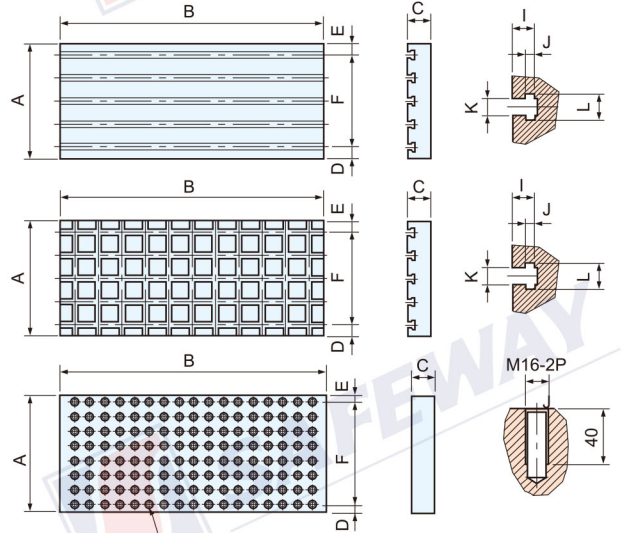

PITCH/孔距:50m/m K/孔: M16×2P×40L

Unit: mm

Order NO. 訂購編號	Model 型號	A	B	C	D	E	F	K	Remark 備註
07870002	ST-300× 600×70	300	600	70					
07870004	ST-350× 800×75	350	800	75					
07870006	ST-400× 950×75	400	950	75					
07870008	ST-410× 900×75	410	900	75					
07870010	ST-450× 900×75	450	900	75					
07870012	ST-500×1000×75	500	1000	75					
07870014	ST-510× 850×75	510	850	75					
07870016	ST-510×1000×75	510	1000	75					
07870018	ST-510×1200×75	510	1200	75					
07870020	ST-510×1300×75	510	1300	75					
07870022	ST-550×1200×75	550	1200	75					
07870024	ST-600×1200×75	600	1200	75					
07870026	ST-600×1500×80	600	1500	80					
07870028	ST-650×1600×80	650	1600	80					
07870030	ST-650×1700×80	650	1700	80					
07870032	ST-700×1700×80	700	1700	80					
07870034	ST-800×2300×85	800	2300	85					
07870036	ST-850×2100×85	850	2100	85					
07870038	ST-850×2300×85	850	2300	85					
07870040	ST-900×2400×85	900	2400	85					
07872002	SC-300× 600×70	300	600	70					
07872004	SC-350× 800×75	350	800	75					
07872006	SC-400× 950×75	400	950	75					
07872008	SC-410× 900×75	410	900	75					
07872010	SC-450× 900×75	450	900	75					
07872012	SC-500×1000×75	500	1000	75					
07872014	SC-510× 850×75	510	850	75					
07872016	SC-510×1000×75	510	1000	75					
07872018	SC-510×1200×75	510	1200	75					
07872020	SC-510×1300×75	510	1300	75					
07872022	SC-550×1200×75	550	1200	75					
07872024	SC-600×1200×75	600	1200	75					
07872026	SC-600×1500×80	600	1500	80					

Order NO. 訂購編號	Model 型號	A	B	C	D	E	F	K	Remark 備註
07872028	SC-650×1600×80	650	1600	80					
07872030	SC-650×1700×80	650	1700	80					
07872032	SC-700×1700×80	700	1700	80					
07872034	SC-800×2300×85	800	2300	85					
07872036	SC-850×2100×85	850	2100	85					
07872038	SC-850×2300×85	850	2300	85					
07872040	SC-900×2400×85	900	2400	85					
07874002	SH-300× 600×70	300	600	70					
07874004	SH-350× 800×75	350	800	75					
07874006	SH-400× 950×75	400	950	75					
07874008	SH-410× 900×75	410	900	75					
07874010	SH-450× 900×75	450	900	75					
07874012	SH-500×1000×75	500	1000	75					
07874014	SH-510× 850×75	510	850	75					
07874016	SH-510×1000×75	510	1000	75					
07874018	SH-510×1200×75	510	1200	75					
07874020	SH-510×1300×75	510	1300	75					
07874022	SH-550×1200×75	550	1200	75					
07874024	SH-600×1200×75	600	1200	75					
07874026	SH-600×1500×80	600	1500	80					
07874028	SH-650×1600×80	650	1600	80					
07874030	SH-650×1700×80	650	1700	80					
07874032	SH-700×1700×80	700	1700	80					
07874034	SH-800×2300×85	800	2300	85					
07874036	SH-850×2100×85	850	2100	85					
07874038	SH-850×2300×85	850	2300	85					
07874040	SH-900×2400×85	900	2400	85					
07874042	SH-340× 510×30	340	510	30					
07874044	SH-340× 660×30	340	660	30					
07874046	SH-405× 600×35	405	600	35					
07874048	SH-405× 780×35	405	780	35					
07874050	SH-495× 720×40	495	720	40					
07874052	SH-495× 940×40	495	940	40					



**MC SUB TABLE**  
**MC 精密治具板**

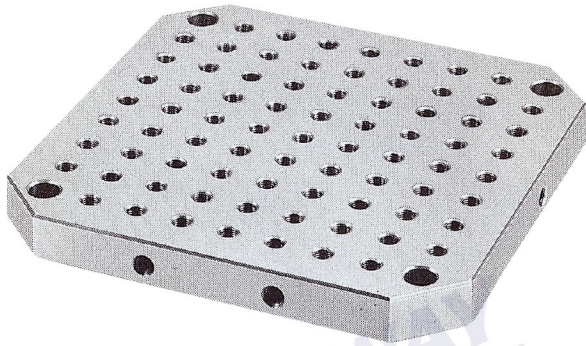

**FEATURES :**

- Both ground & paralleled within 0.010/500mm
- Material: FCD600~60kgs/mm<sup>2</sup> ductile iron.  
(High tensile casting)
- Annealing.

**特性:**

- 兩面精密研磨0.010/500mm
- 材質：球狀石墨化鑄鐵FCD600~60kgs/mm<sup>2</sup>
- 退火處理。

※Please fill D.E.F.K.PITCH dimension of yourself.  
D.E.F.K間格數請客戶自行填上，並告知機械機種。

- MODEL • 07876002 SP-300×300×40  
• 07876004 SP-400×400×40  
• 07876006 SP-500×500×40  
• 07876008 SP-600×600×45  
• 07876010 SP-630×630×40

- MODEL • 07878002 SL-400×400×70  
• 07878004 SL-500×500×70  
• 07878006 SL-630×630×70  
• 07878008 SL-800×800×70

- MODEL • 07880002 SM-300×300×40  
• 07880004 SM-400×400×40  
• 07880006 SM-500×500×40  
• 07880008 SM-600×600×45  
• 07880010 SM-630×630×40  
• 07880012 SM-400×400×70  
• 07880014 SM-500×500×70  
• 07880016 SM-630×630×70  
• 07880018 SM-800×800×70

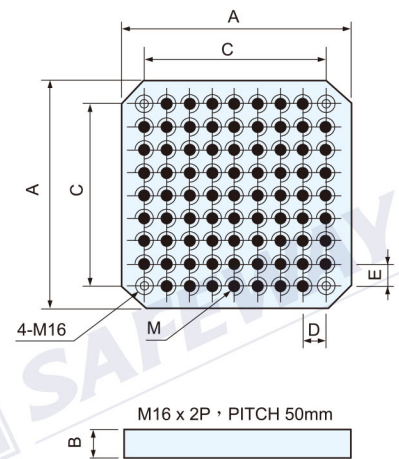
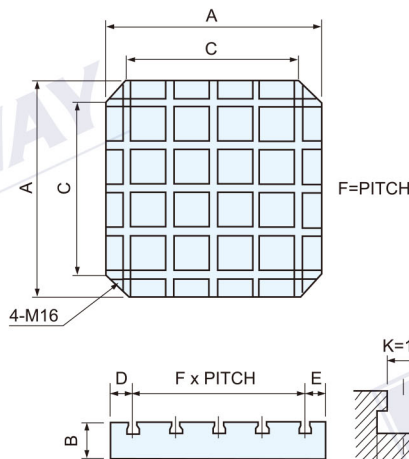
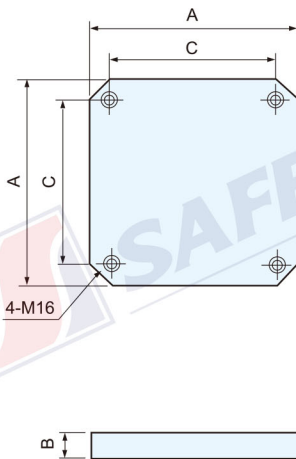

SUB-TABLE

※ Accept special order / 接受特別尺寸訂製

Unit: mm

Order NO. 訂購編號	Model 型號	A	B	C	D	F	K	Remark 備註
07876002	SP-300×300×40	300	40	240				
07876004	SP-400×400×40	400	40	300				
07876006	SP-500×500×40	500	40	400				
07876008	SP-600×600×45	600	45	500				
07876010	SP-630×630×40	630	40	500				
07878002	SL-400×400×70	400	70	300	50	100	18	
07878004	SL-500×500×70	500	70	400	50	100	18	
07878006	SL-630×630×70	630	70	500	65	100	18	
07878008	SL-800×800×70	800	70	700	50	100	18	

Order NO. 訂購編號	Model 型號	A	B	C	D	E	F	K	Remark 備註
07880002	SM-300×300×40	300	40	240	50	50			
07880004	SM-400×400×40	400	40	320	50	50			
07880006	SM-500×500×40	500	40	400	50	50			
07880008	SM-600×600×45	600	45	500	50	50			
07880010	SM-630×630×40	630	40	500	50	50			
07880012	SM-400×400×70	400	70	320	50	50			
07880014	SM-500×500×70	500	70	400	50	50			
07880016	SM-630×630×70	630	70	500	50	50			
07880018	SM-800×800×70	800	70	700	50	50			



**MC TOOLING BLOCKS (4 FACE TYPE)**

**MC 四面基座**



- MODEL
- 07882002 SJB-400×250×500B
  - 07882014 SJB-800×550×850B
  - 07882004 SJB-500×300×600B
  - 07882022 SJB-400×250×660B
  - 07882006 SJB-500×350×550B
  - 07882024 SJB-500×350×700B
  - 07882008 SJB-630×350×700B
  - 07882026 SJB-630×450×860B
  - 07882010 SJB-630×400×700B
  - 07882028 SJB-800×550×1000B
  - 07882012 SJB-630×500×700B

**FEATURES :**

- Material: FCD600~60kgs/mm<sup>2</sup> ductile iron. (High tensile casting)
- Heat-Treatment-Annealing.
- One piece casting of bed and column.
- Accept special order.

**特性 :**

- 材質：球狀石墨化鑄鐵FCD600~60kgs/mm<sup>2</sup>
- 燒鈍熱處理。
- 適合臥式綜合切削加工機，重切削加工使用。
- 基座一體成形，剛性佳，適重切削。
- 接受特殊規格訂製，交貨期及價格另議。

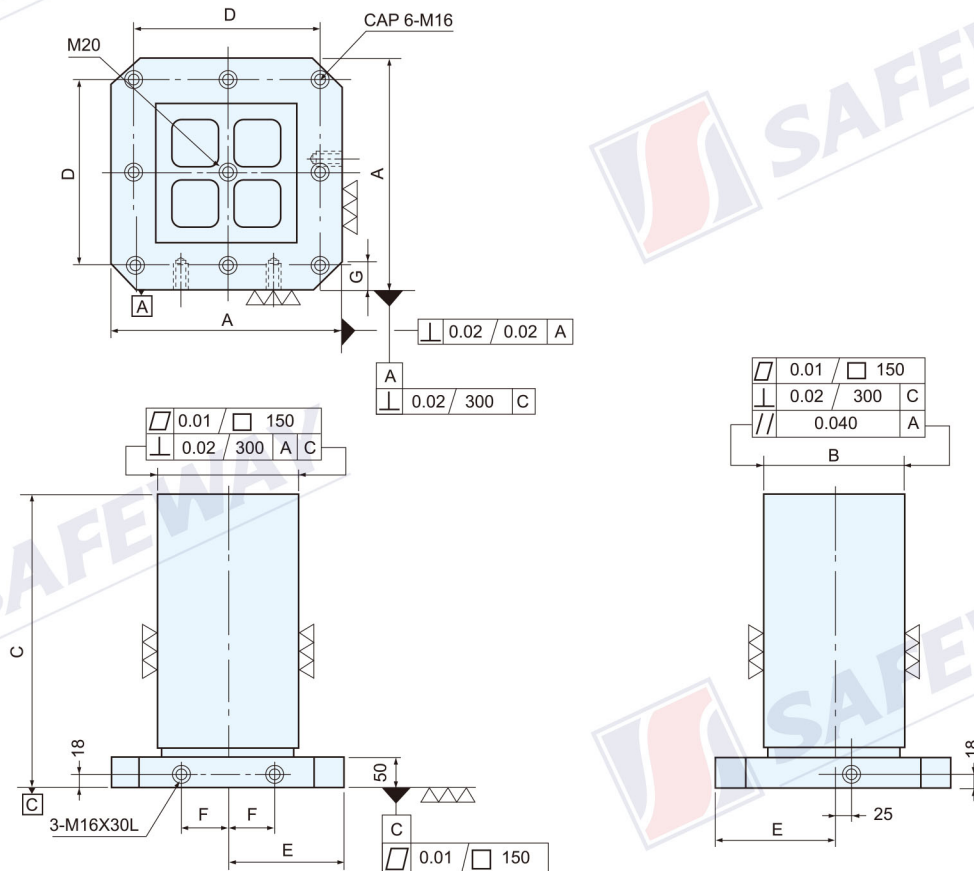

Unit: mm

Order NO. 訂購編號	Model 型號	A	B	C	D	E	F	G	N.W 淨重	Remark 備註
07882002	SJB-400×250×500B	400	250	500	320	200	55	50	195kg	
07882004	SJB-500×300×600B	500	300	600	400	250	75	60	315kg	
07882006	SJB-500×350×550B	500	350	550	400	250	75	60	345kg	
07882008	SJB-630×350×700B	630	350	700	500	315	100	65	449kg	
07882010	SJB-630×400×700B	630	400	700	500	315	100	65	500kg	
07882012	SJB-630×500×700B	630	500	700	500	315	100	65	595kg	
07882014	SJB-800×550×850B	800	550	850	640	400	135	80	811kg	
07882022	SJB-400×250×660B	400	250	660	320	200	55	50	215kg	
02882024	SJB-500×350×700B	500	350	700	400	250	75	60	328kg	
07882026	SJB-630×450×860B	630	450	860	500	315	100	65	582kg	
07882028	SJB-800×550×1000B	800	550	1000	640	400	135	100	795kg	



**MC TOOLING BLOCKS (4 FACE TYPE-T-SLOTS)**

**MC 四面基座 (T型槽)**



- |                                   |                             |
|-----------------------------------|-----------------------------|
| MODEL • 07884002 SJB-400×250×500T | • 07884202 SJB-400×250×500L |
| • 07884004 SJB-500×300×600T       | • 07884204 SJB-500×300×600L |
| • 07884006 SJB-500×350×550T       | • 07884206 SJB-500×350×550L |
| • 07884008 SJB-630×350×700T       | • 07884208 SJB-630×350×700L |
| • 07884010 SJB-630×400×700T       | • 07884210 SJB-630×400×700L |
| • 07884012 SJB-630×500×700T       | • 07884212 SJB-630×500×700L |
| • 07884014 SJB-800×550×850T       | • 07884214 SJB-800×550×850L |

**FEATURES :**

- Material: FCD600~60kgs/mm<sup>2</sup> ductile iron. (High tensile casting)
- Heat-Treatment-Annealing.
- One piece casting of bed and column.
- Accept special order.

**特性 :**

- 材質：球狀石墨化鑄鐵FCD600~60kgs/mm<sup>2</sup>
- 燒鈍熱處理。
- 適合臥式綜合切削加工機，重切削加工使用。
- 基座一體成形，剛性佳，適重切削。
- 接受特殊規格訂製，交貨期及價格另議。

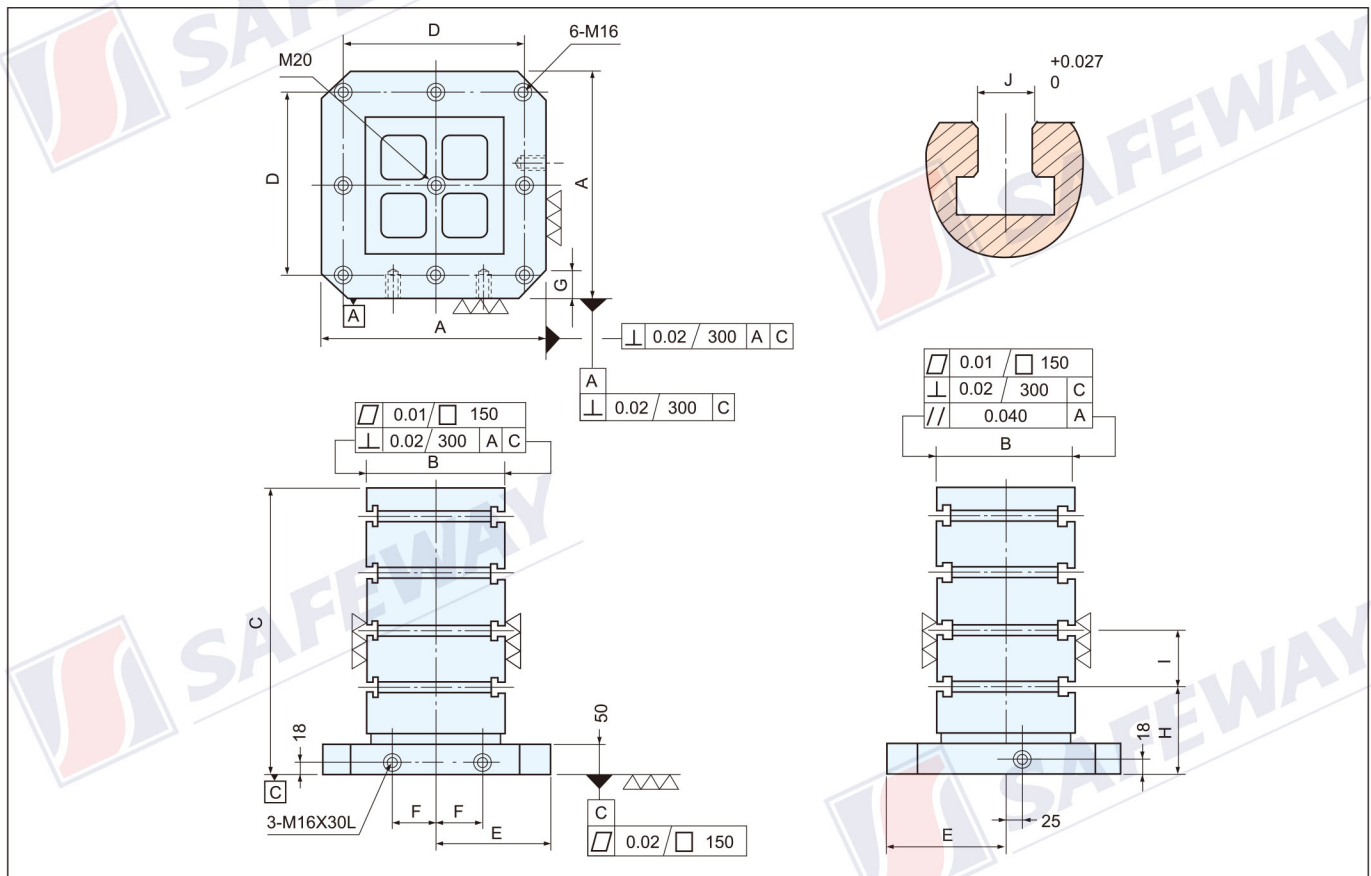

Unit: mm

Order NO. 訂購編號	Model 型號	A	B	C	D	E	F	G	H	I	J	N.W. 淨重	Remark 備註
07884002	SJB-400×250×500T	400	250	500	320	200	55	50	150	100x4	14	177kg	
07884004	SJB-500×300×600T	500	300	600	400	250	75	60	150	100x5	14	290kg	
07884006	SJB-500×350×550T	500	350	550	400	250	75	60	150	100x4	14	291kg	
07884008	SJB-630×350×700T	630	350	700	500	315	100	65	150	125x5	14	428kg	
07884010	SJB-630×400×700T	630	400	700	500	315	100	65	150	125x5	14	470kg	
07884012	SJB-630×500×700T	630	500	700	500	315	100	65	150	125x5	14	560kg	
07884014	SJB-800×550×850T	800	550	850	640	400	135	80	150	150x5	14	770kg	
07884202	SJB-400×250×500L	400	250	500	320	200	55	50	150	100x4	18	174kg	
07884204	SJB-500×300×600L	500	300	600	400	250	75	60	150	100x5	18	287kg	
07884206	SJB-500×350×550L	500	350	550	400	250	75	60	150	100x4	18	286kg	
07884208	SJB-630×350×700L	630	350	700	500	315	100	65	150	125x5	18	423kg	
07884210	SJB-630×400×700L	630	400	700	500	315	100	65	150	125x5	18	465kg	
07884212	SJB-630×500×700L	630	500	700	500	315	100	65	150	125x5	18	552kg	
07884214	SJB-800×550×850L	800	550	850	640	400	135	80	150	150x5	18	714kg	



**MC TOOLING BLOCKS (4 FACE TYPE-TAPPING)**

**MC 四面基座 (鑽孔 / 攻牙)**



- |       |                             |                             |
|-------|-----------------------------|-----------------------------|
| MODEL | • 07886002 SJB-400×250×500M | • 07886202 SJB-400×250×500H |
|       | • 07886004 SJB-500×300×600M | • 07886204 SJB-500×300×600H |
|       | • 07886006 SJB-500×350×550M | • 07886206 SJB-500×350×550H |
|       | • 07886008 SJB-630×350×700M | • 07886208 SJB-630×350×700H |
|       | • 07886010 SJB-630×400×700M | • 07886210 SJB-630×400×700H |
|       | • 07886012 SJB-630×500×700M | • 07886212 SJB-630×500×700H |
|       | • 07886014 SJB-800×550×850M | • 07886214 SJB-800×550×850H |

**FEATURES :**

- Material: FCD600~60kgs/mm<sup>2</sup> ductile iron. (High tensile casting)
- Heat-Treatment-Annealing.
- One piece casting of bed and column.
- Accept special order.

**特性 :**

- 材質：球狀石墨化鑄鐵FCD600~60kgs/mm<sup>2</sup>
- 燒鈍熱處理。
- 適合臥式綜合切削加工機，重切削加工使用。
- 基座一體成形，剛性佳，適重切削。
- 接受特殊規格訂製，交貨期及價格另議。

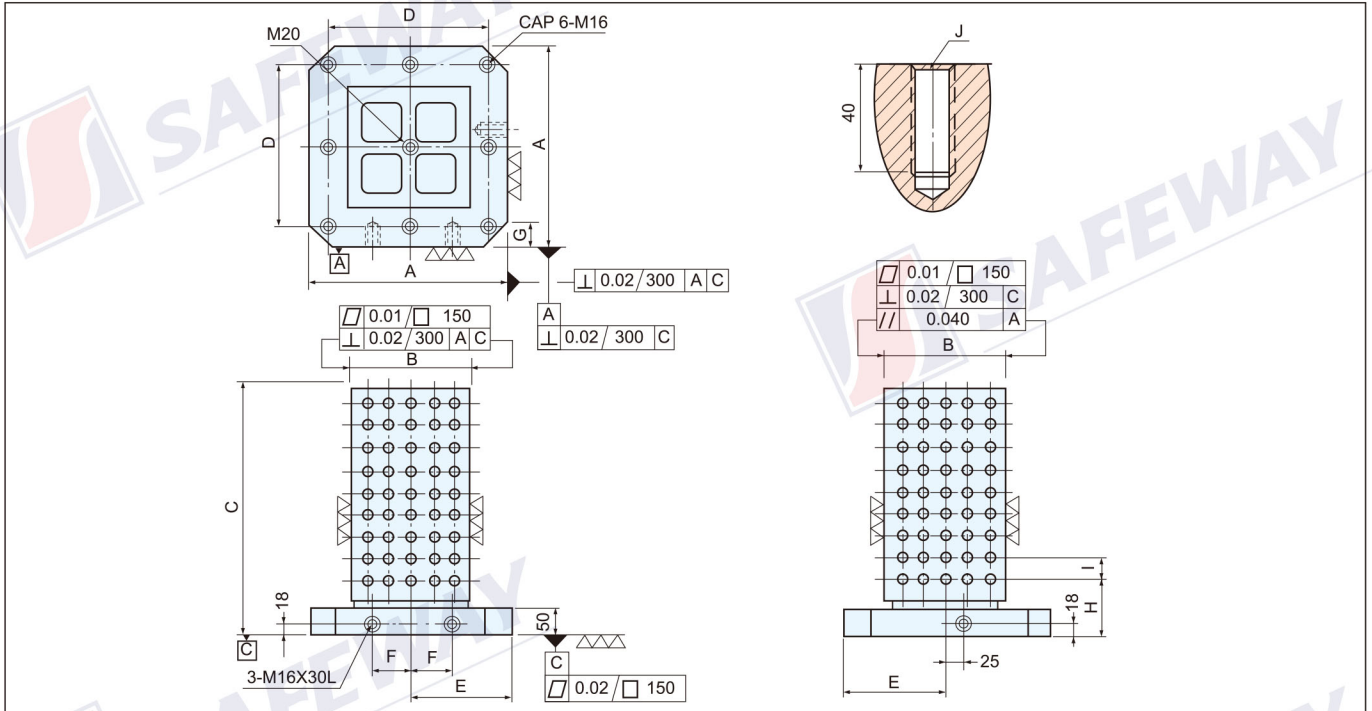

Unit: mm

Order NO. 訂購編號	Model 型號	A	B	C	D	E	F	G	H	I	J	N.W. 淨重	Remark 備註
07886002	SJB-400×250×500M	400	250	500	320	200	55	50	150	50	M12-4x7x4=112	193kg	
07886004	SJB-500×300×600M	500	300	600	400	250	75	60	150	50	M12-5x9x4=180	294kg	
07886006	SJB-500×350×550M	500	350	550	400	250	75	60	150	50	M12-6x8x4=192	312kg	
07886008	SJB-630×350×700M	630	350	700	500	315	100	65	150	50	M12-6x11x4=264	438kg	
07886010	SJB-630×400×700M	630	400	700	500	315	100	65	150	50	M12-7x11x4=308	460kg	
07886012	SJB-630×500×700M	630	500	700	500	315	100	65	150	50	M12-9x11x4=396	570kg	
07886014	SJB-800×550×850M	800	550	850	640	400	135	80	150	50	M12-10x14x4=560	780kg	
07886022	SJB-400×250×660M	400	250	660	320	200	55	50	150	50	M12-4x10x4=160	213kg	
07886024	SJB-500×350×700M	500	350	700	400	250	75	60	150	50	M12-5x11x4=220	309kg	
07886026	SJB-630×450×860M	630	450	860	500	315	100	65	150	50	M12-6x14x4=336	582kg	
07886028	SJB-800×550×1000M	800	550	1000	640	400	135	100	150	50	M12-10x17x4=680	795kg	
07886202	SJB-400×250×500H	400	250	500	320	200	55	50	150	50	M16-4x7x4=112	189kg	
07886204	SJB-500×300×600H	500	300	600	400	250	75	60	150	50	M16-5x9x4=180	290kg	
07886206	SJB-500×350×550H	500	350	550	400	250	75	60	150	50	M16-6x8x4=192	308kg	
07886208	SJB-630×350×700H	630	350	700	500	315	100	65	150	50	M16-6x11x4=264	433kg	
07886210	SJB-630×400×700H	630	400	700	500	315	100	65	150	50	M16-7x11x4=308	455kg	
07886212	SJB-630×500×700H	630	500	700	500	315	100	65	150	50	M16-9x11x4=396	565kg	
07886214	SJB-800×550×850H	800	550	850	640	400	135	80	150	50	M16-10x14x4=560	776kg	
07886222	SJB-400×250×660H	400	250	660	320	200	55	50	150	50	M16-4x10x4=160	209kg	
07886224	SJB-500×350×700H	500	350	700	400	250	75	60	150	50	M16-5x11x4=220	305kg	
07886226	SJB-630×450×860H	630	450	860	500	315	100	65	150	50	M16-6x14x4=336	578kg	
07886228	SJB-800×550×1000H	800	550	1000	640	400	135	100	150	50	M16-10x17x4=680	785kg	



**MC TOOLING BLOCKS (2 FACE TYPE)**

**MC 二面基座**



- MODEL
- 07886402 SJB-400×150×500P
  - 07886412 SJB-400×150×660P
  - 07886404 SJB-500×200×600P
  - 07886414 SJB-500×150×700P
  - 07886406 SJB-630×250×700P
  - 07886416 SJB-630×200×860P
  - 07886408 SJB-800×300×800P
  - 07886418 SJB-800×300×1000P

**FEATURES :**

- Material: FCD600~60kgs/mm<sup>2</sup> ductile iron. (High tensile casting)
- Heat-Treatment-Annealing.
- One piece casting of bed and column.
- Accept special order.

**特性：**

- 材質：球狀石墨化鑄鐵FCD600~60kgs/mm<sup>2</sup>
- 燒鈍熱處理。
- 適合臥式綜合切削加工機，重切削加工使用。
- 基座一體成形，剛性佳，適重切削。
- 接受特殊規格訂製，交貨期及價格另議。

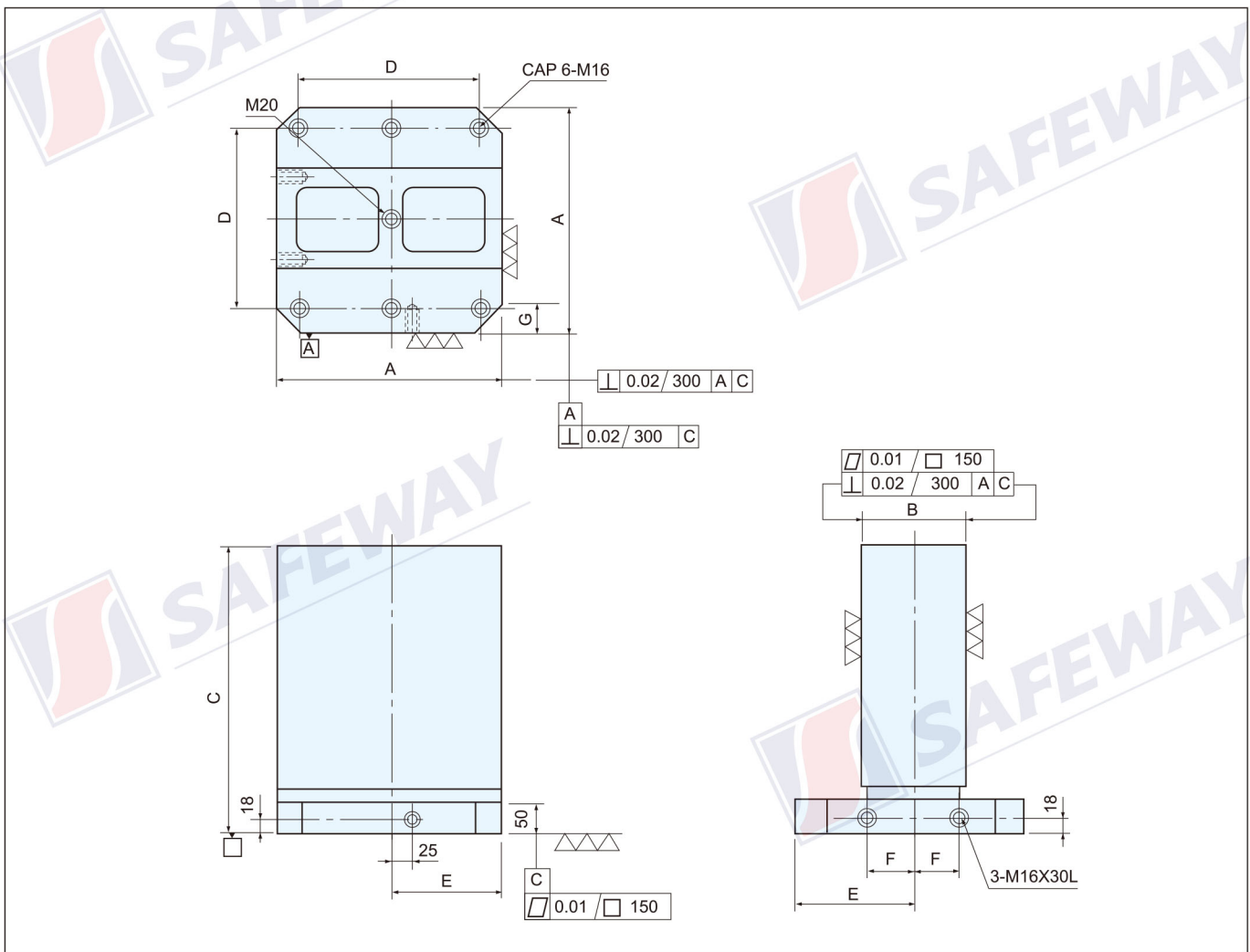

SJB-04

Unit: mm

Order NO. 訂購編號	Model 型號	A	B	C	D	E	F	G	N.W. 淨重	Remark 備註
07886402	SJB-400×150×500P	400	150	500	320	200	55	50	218kg	
07886404	SJB-500×200×600P	500	200	600	400	250	75	60	320kg	
07886406	SJB-630×250×700P	630	250	700	500	315	100	65	578kg	
07886408	SJB-800×300×800P	800	300	800	640	400	135	80	776kg	
07886412	SJB-400×150×660P	400	150	660	300	200	55	50	207kg	
07886414	SJB-500×150×700P	500	150	700	400	250	75	60	280kg	
07886416	SJB-630×200×860P	630	200	860	500	315	100	65	504kg	
07886418	SJB-800×300×1000P	800	300	1000	640	400	135	100	810kg	



**MC TOOLING BLOCKS (2 FACE T-SLOTS)**  
**MC 二面基座 (T型槽)**



- MODEL • 07886602 SJB-400×150×500R • 07886802 SJB-400×150×500S  
 • 07886604 SJB-500×200×600R • 07886804 SJB-500×200×600S  
 • 07886606 SJB-630×250×700R • 07886806 SJB-630×250×700S  
 • 07886608 SJB-800×300×800R • 07886808 SJB-800×300×800S

**FEATURES :**

- Material: FCD600~60kgs/mm<sup>2</sup> ductile iron. (High tensile casting)
- Heat-Treatment-Annealing.
- One piece casting of bed and column.
- Accept special order.

**特性 :**

- 材質：球狀石墨化鑄鐵FCD600~60kgs/mm<sup>2</sup>
- 燒鈍熱處理。
- 適合臥式綜合切削加工機，重切削加工使用。
- 基座一體成形，剛性佳，適重切削。
- 接受特殊規格訂製，交貨期及價格另議。

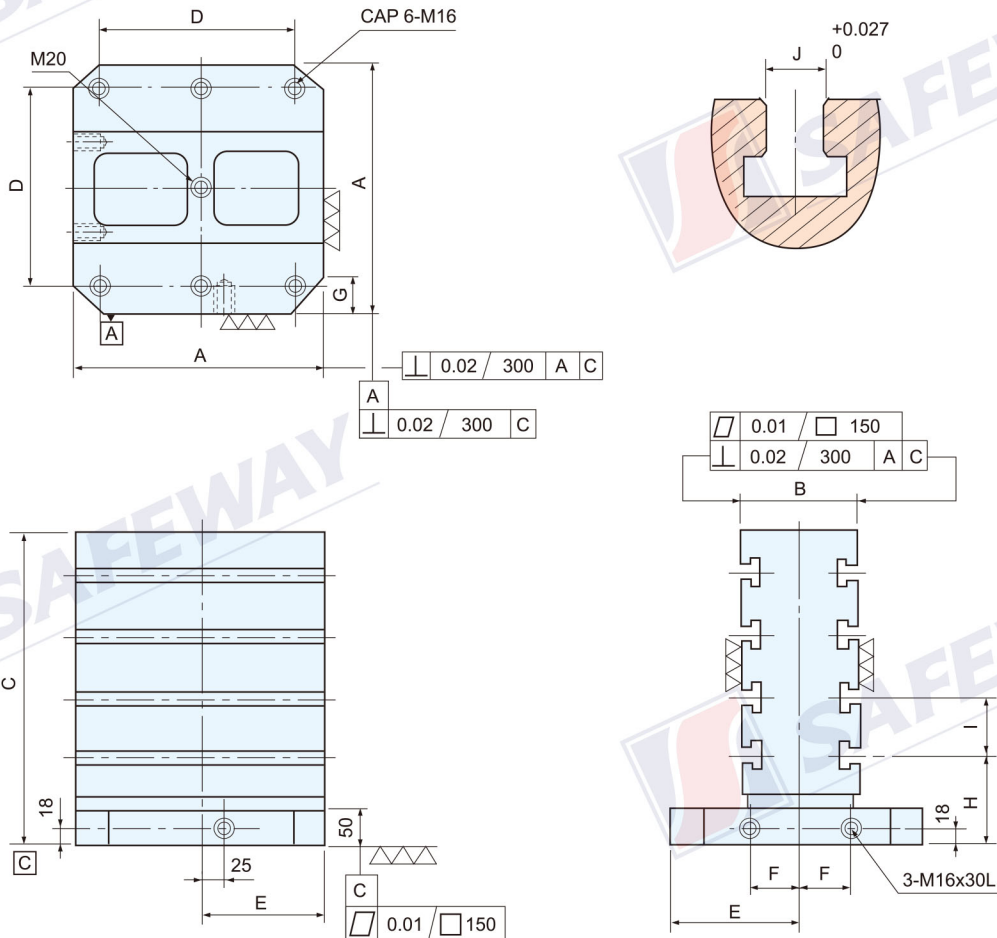

SJB-05

Unit: mm

Order NO. 訂購編號	Model 型號	A	B	C	D	E	F	G	H	I	J	N.W. 淨重	Remark 備註
07886602	SJB-400×150×500R	400	150	500	320	200	55	50	150	100x4	14	204kg	
07886604	SJB-500×200×600R	500	200	600	400	250	75	60	150	100x5	14	305kg	
07886606	SJB-630×250×700R	630	250	700	500	315	100	65	150	125x5	14	560kg	
07886608	SJB-800×300×800R	800	300	800	640	400	135	80	150	150x5	14	752kg	
07886802	SJB-400×150×500S	400	150	500	320	200	55	50	150	100x4	18	198kg	
07886804	SJB-500×200×600S	500	200	600	400	250	75	60	150	100x5	18	304kg	
07886806	SJB-630×250×700S	630	250	700	500	315	100	65	150	125x5	18	578kg	
07886808	SJB-800×300×800S	800	300	800	640	400	135	80	150	150x5	18	740kg	





**MC TOOLING BLOCKS (2 FACE TYPE-TAPPING)**

MC 二面基座 (鑽孔 / 攻牙)

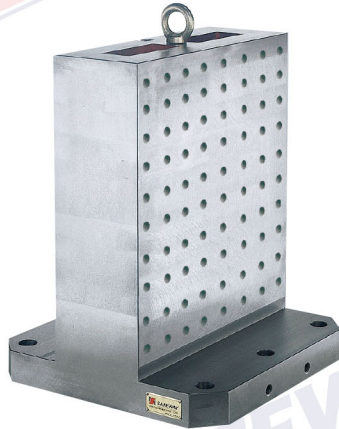

- MODEL
- 07887002 SJB-400×150×500U
  - 07887202 SJB-400×150×500V
  - 07887004 SJB-500×200×600U
  - 07887204 SJB-500×200×600V
  - 07887006 SJB-630×250×700U
  - 07887206 SJB-630×250×700V
  - 07887008 SJB-800×300×800U
  - 07887208 SJB-800×300×800V

**FEATURES :**

- Material: FCD600~60kgs/mm<sup>2</sup> ductile iron. (High tensile casting)
- Heat-Treatment-Annealing.
- One piece casting of bed and column.
- Accept special order.

**特性 :**

- 材質：球狀石墨化鑄鐵FCD600~60kgs/mm<sup>2</sup>
- 燒鈍熱處理。
- 適合臥式綜合切削加工機，重切削加工使用。
- 基座一體成形，剛性佳，適重切削。
- 接受特殊規格訂製，交貨期及價格另議。

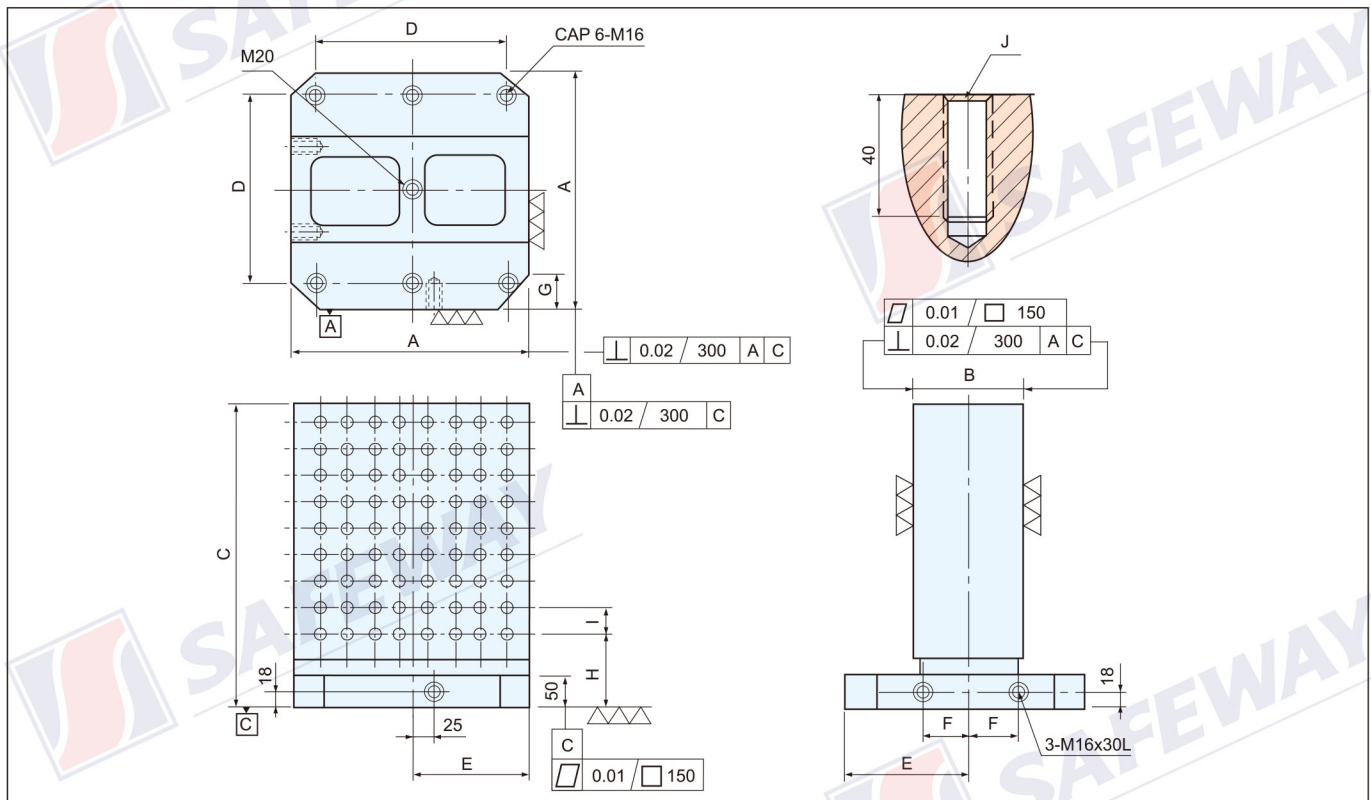

Unit: mm

Order NO. 訂購編號	Model 型號	A	B	C	D	E	F	G	H	I	J	N.W. 淨重	Remark 備註
07887002	SJB-400×150×500U	400	150	500	320	200	55	50	150	50	M12-7x7x2=98	206kg	
07887004	SJB-500×200×600U	500	200	600	400	250	75	60	150	50	M12-9x9x2=162	315kg	
07887006	SJB-630×250×700U	630	250	700	500	315	100	65	150	50	M12-11x11x2=242	568kg	
07887008	SJB-800×300×800U	800	300	800	640	400	135	80	150	50	M12-15x13x2=390	762kg	
07887012	SJB-400×150×660U	400	150	660	320	200	55	50	150	50	M12-7x10x2=140	207kg	
07887014	SJB-500×150×700U	500	150	700	400	250	75	60	150	50	M12-9x11x2=198	280kg	
07887016	SJB-630×200×860U	630	200	860	500	315	100	65	150	50	M12-11x14x2=308	504kg	
07887018	SJB-800×300×1000U	800	300	1000	640	400	135	100	150	50	M12-15x17x2=510	810kg	
07887202	SJB-400×150×500V	400	150	500	320	200	55	50	150	50	M16-7x7x2=98	204kg	
07887204	SJB-500×200×600V	500	200	600	400	250	75	60	150	50	M16-9x9x2=162	307kg	
07887206	SJB-630×250×700V	630	250	700	500	315	100	65	150	50	M16-11x11x2=242	564kg	
07887208	SJB-800×300×800V	800	300	800	640	400	135	80	150	50	M16-15x13x2=390	755kg	
07887212	SJB-400×150×660V	400	150	660	320	200	55	50	150	50	M16-7x10x2=140	205kg	
07887214	SJB-500×150×700V	500	150	700	400	250	75	60	150	50	M16-9x11x2=198	272kg	
07887216	SJB-630×200×860V	630	200	860	500	315	100	65	150	50	M16-11x14x2=308	500kg	
07887218	SJB-800×300×1000V	800	300	1000	640	400	135	100	150	50	M16-15x17x2=510	803kg	



**MC TOOLING BLOCKS (CROSS COLUMN)**  
**MC 十字基座**



- MODEL
- 07888402 SJB-400×150×550SC
  - 07888404 SJB-400×150×650SC
  - 07888406 SJB-500×160×650SC
  - 07888408 SJB-500×160×750SC
  - 07888410 SJB-630×200×750SC
  - 07888412 SJB-630×200×850SC
  - 07888414 SJB-800×250×850SC
  - 07888416 SJB-800×250×1000SC

**FEATURES :**

- Material: FCD600~60kgs/mm<sup>2</sup> ductile iron. (High tensile casting)
- Heat-Treatment-Annealing.
- One piece casting of bed and column.
- Accept special order.

**特性：**

- 材質：球狀石墨化鑄鐵FCD600~60kgs/mm<sup>2</sup>
- 燒鈍熱處理。
- 適合臥式綜合切削加工機，重切削加工使用。
- 基座一體成形，剛性佳，適重切削。
- 接受特殊規格訂製，交貨期及價格另議。

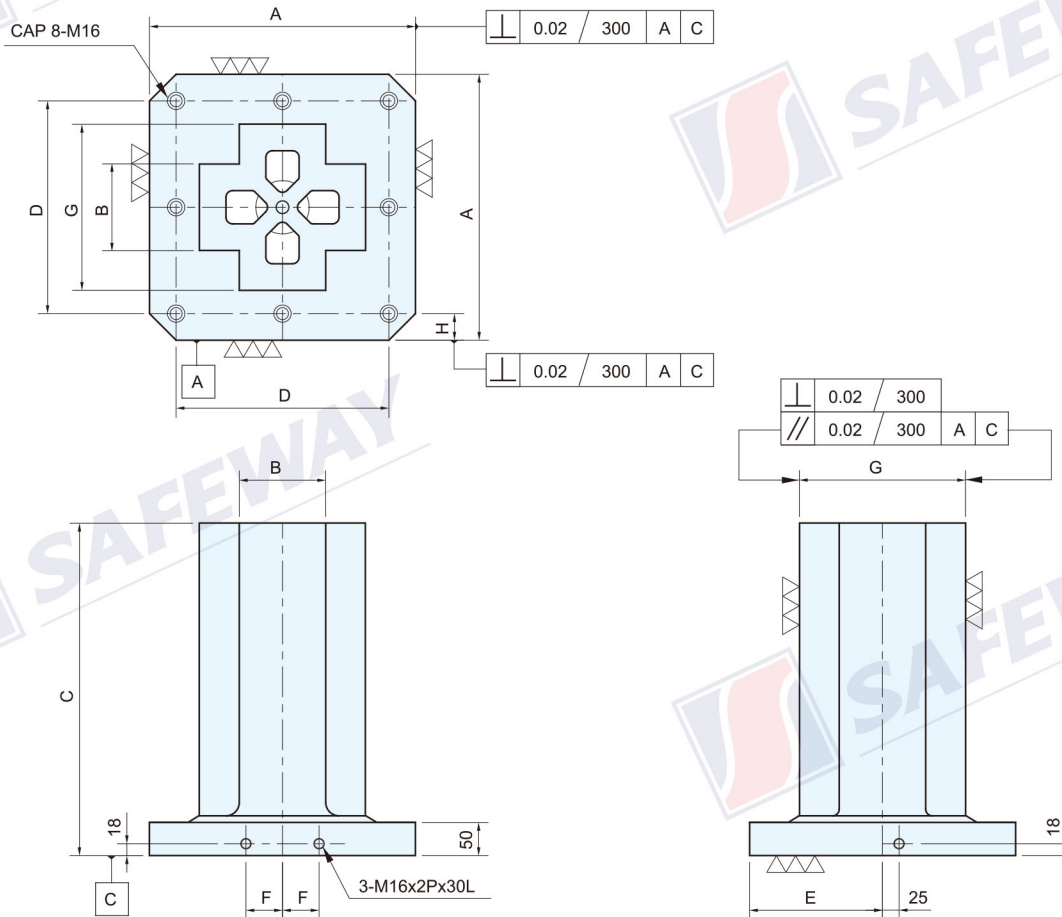

Unit: mm

Order NO. 訂購編號	Model 型號	A	B	C	D	E	F	G	H	N.W. 淨重	Remark 備註
07888402	SJB-400×150×550SC	400	150	550	320	200	55	250	40		
07888404	SJB-400×150×650SC	400	150	650	320	200	55	250	40		
07888406	SJB-500×160×650SC	500	160	650	400	250	75	300	50		
07888408	SJB-500×160×750SC	500	160	750	400	250	75	300	50		
07888410	SJB-630×200×750SC	630	200	750	500	315	100	360	65		
07888412	SJB-630×200×850SC	630	200	850	500	315	100	360	65		
07888414	SJB-800×250×850SC	800	250	850	640	400	135	500	80		
07888416	SJB-800×250×1000SC	800	250	1000	640	400	135	500	80		



**MC TOOLING BLOCKS (CROSS COLUMN-TAPPING)**

MC 十字基座 (鑽孔 / 攻牙)



- MODEL
- 07888602 SJB-400×150×550TC
  - 07888802 SJB-400×150×550UC
  - 07888604 SJB-400×150×650TC
  - 07888804 SJB-400×150×650UC
  - 07888606 SJB-500×160×650TC
  - 07888806 SJB-500×160×650UC
  - 07888608 SJB-500×160×750TC
  - 07888808 SJB-560×160×750UC
  - 07888610 SJB-630×200×750TC
  - 07888810 SJB-630×200×750UC
  - 07888612 SJB-630×200×850TC
  - 07888812 SJB-630×200×850UC
  - 07888614 SJB-800×250×850TC
  - 07888814 SJB-800×250×850UC
  - 07888616 SJB-800×250×1000TC
  - 07888816 SJB-800×250×1000UC

**FEATURES :**

- Material: FCD600~60kgs/mm<sup>2</sup> ductile iron. (High tensile casting)
- Heat-Treatment-Annealing.
- One piece casting of bed and column.
- Accept special order.

**特性 :**

- 材質：球狀石墨化鑄鐵FCD600~60kgs/mm<sup>2</sup>
- 燒鈍熱處理。
- 適合臥式綜合切削加工機，重切削加工使用。
- 基座一體成形，剛性佳，適重切削。
- 接受特殊規格訂製，交貨期及價格另議。

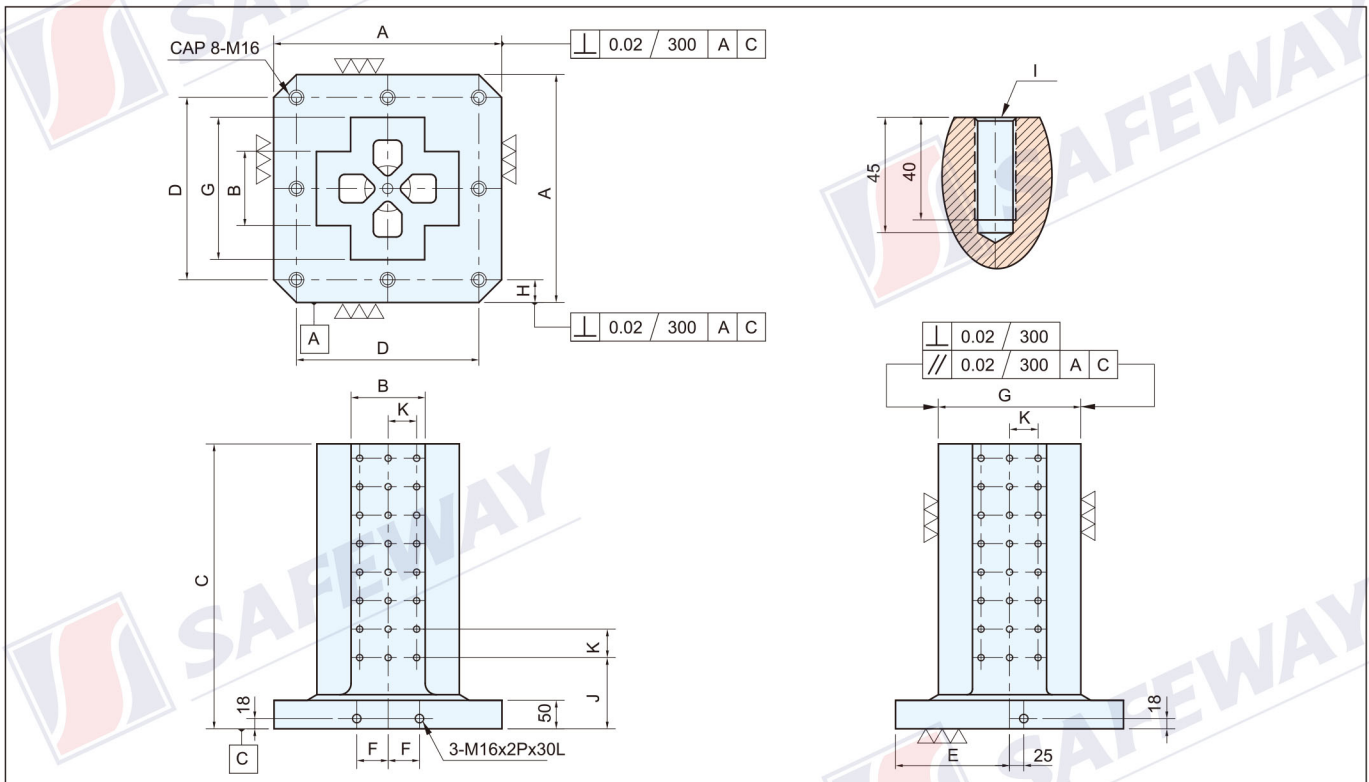

Unit: mm

Order NO. 訂購編號	Model 型號	A	B	C	D	E	F	G	H	I	J	K	N.W. 淨重	Remark 備註
07888602	SJB-400×150×550TC	400	150	550	320	200	55	250	40	12	150	50		
07888604	SJB-400×150×650TC	400	150	650	320	200	55	250	40	12	150	50		
07888606	SJB-500×160×650TC	500	160	650	400	250	75	300	50	12	150	50		
07888608	SJB-500×160×750TC	500	160	750	400	250	75	300	50	12	150	50		
07888610	SJB-630×200×750TC	630	200	750	500	315	100	350	65	12	150	50		
07888612	SJB-630×200×850TC	630	200	850	500	315	100	350	65	12	150	50		
07888614	SJB-800×250×850TC	800	250	850	640	400	135	500	80	12	150	50		
07888616	SJB-800×250×1000TC	800	250	1000	640	400	135	500	80	12	150	50		
07888802	SJB-400×150×550UC	400	150	550	320	200	55	250	40	16	150	50		
07888804	SJB-400×150×650UC	400	150	650	320	200	55	250	40	16	150	50		
07888806	SJB-500×160×650UC	500	160	650	400	250	75	300	50	16	150	50		
07888808	SJB-500×160×750UC	500	160	750	400	250	75	300	50	16	150	50		
07888810	SJB-630×200×750UC	630	200	750	500	315	100	350	65	16	150	50		
07888812	SJB-630×200×850UC	630	200	850	500	315	100	350	65	16	150	50		
07888814	SJB-800×250×850UC	800	250	850	640	400	135	500	80	16	150	50		
07888816	SJB-800×250×1000UC	800	250	1000	640	400	135	500	80	16	150	50		



**MC TOOLING BLOCKS (6 FACES)**

**MC 六面基座**

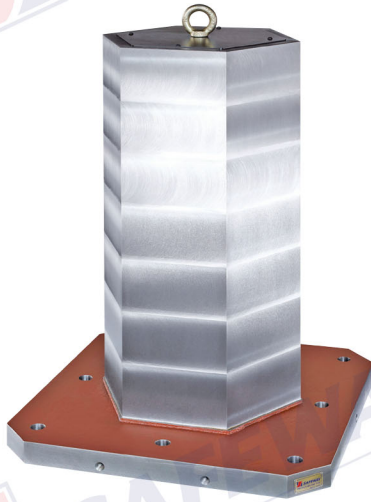

- MODEL • 07889002 SJB-400×144×550J6 • 07889010 SJB-630×205×750J6  
 • 07889004 SJB-400×144×650J6 • 07889012 SJB-630×205×850J6  
 • 07889006 SJB-500×173×650J6 • 07889014 SJB-800×289×850J6  
 • 07889008 SJB-500×173×750J6 • 07889016 SJB-800×289×1000J6

**FEATURES :**

- Material: FCD600~60kgs/mm<sup>2</sup> ductile iron. (High tensile casting)
- Heat-Treatment-Annealing.
- One piece casting of bed and column.
- Accept special order.

**特性：**

- 材質：球狀石墨化鑄鐵FCD600~60kgs/mm<sup>2</sup>
- 燒鈍熱處理。
- 適合臥式綜合切削加工機，重切削加工使用。
- 基座一體成形，剛性佳，適重切削。
- 接受特殊規格訂製，交貨期及價格另議。

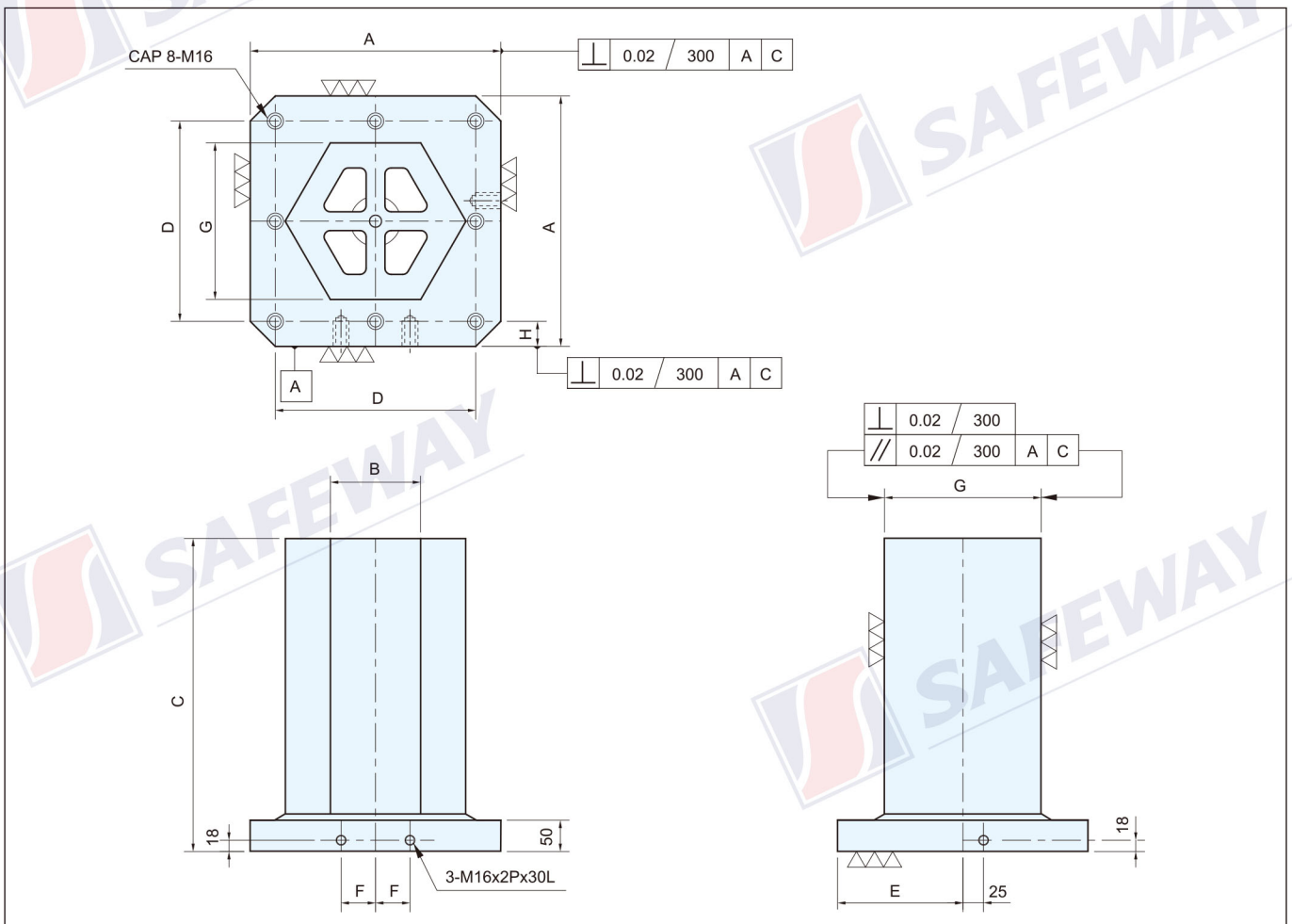

SJB-09

Unit: mm

Order NO. 訂購編號	Model 型號	A	B	C	D	E	F	G	H	N.W. 淨重	Remark 備註
07889002	SJB-400×144×550J6	400	144	550	320	200	55	250	40		
07889004	SJB-400×144×650J6	400	144	650	320	200	55	250	40		
07889006	SJB-500×173×650J6	500	173	650	400	250	75	300	50		
07889008	SJB-500×173×750J6	500	173	750	400	250	75	300	50		
07889010	SJB-630×205×750J6	630	205	750	500	315	100	360	65		
07889012	SJB-630×205×850J6	630	205	850	500	315	100	360	65		
07889014	SJB-800×289×850J6	800	289	850	640	400	135	500	80		
07889016	SJB-800×289×1000J6	800	289	1000	640	400	135	500	80		



**MC TOOLING BLOCKS (6 FACES-TAPPING)**

**MC 六面基座 (鑽孔 / 攻牙)**

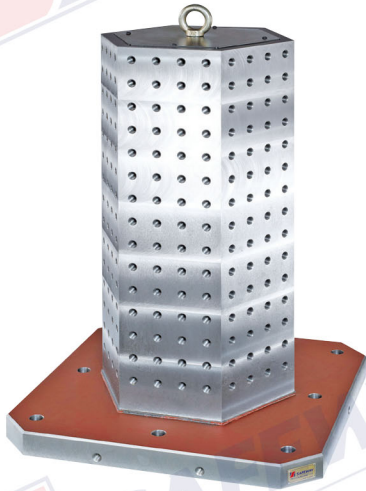

- MODEL • 07889202 SJB-400×144×550K6 • 07889402 SJB-400×144×550M6  
 • 07889204 SJB-400×144×650K6 • 07889404 SJB-400×144×650M6  
 • 07889206 SJB-500×173×650K6 • 07889406 SJB-500×173×650M6  
 • 07889208 SJB-500×173×750K6 • 07889408 SJB-500×173×750M6  
 • 07889210 SJB-630×205×750K6 • 07889410 SJB-630×205×750M6  
 • 07889212 SJB-630×205×850K6 • 07889412 SJB-630×205×850M6  
 • 07889214 SJB-800×289×850K6 • 07889414 SJB-800×289×850M6  
 • 07889216 SJB-800×289×1000K6 • 07889416 SJB-800×289×1000M6

**FEATURES :**

- Material: FCD600~60kgs/mm<sup>2</sup> ductile iron. (High tensile casting)
- Heat-Treatment-Annealing.
- One piece casting of bed and column.
- Accept special order.

**特性 :**

- 材質：球狀石墨化鑄鐵FCD600~60kgs/mm<sup>2</sup>
- 燒鈍熱處理。
- 適合臥式綜合切削加工機，重切削加工使用。
- 基座一體成形，剛性佳，適重切削。
- 接受特殊規格訂製，交貨期及價格另議。

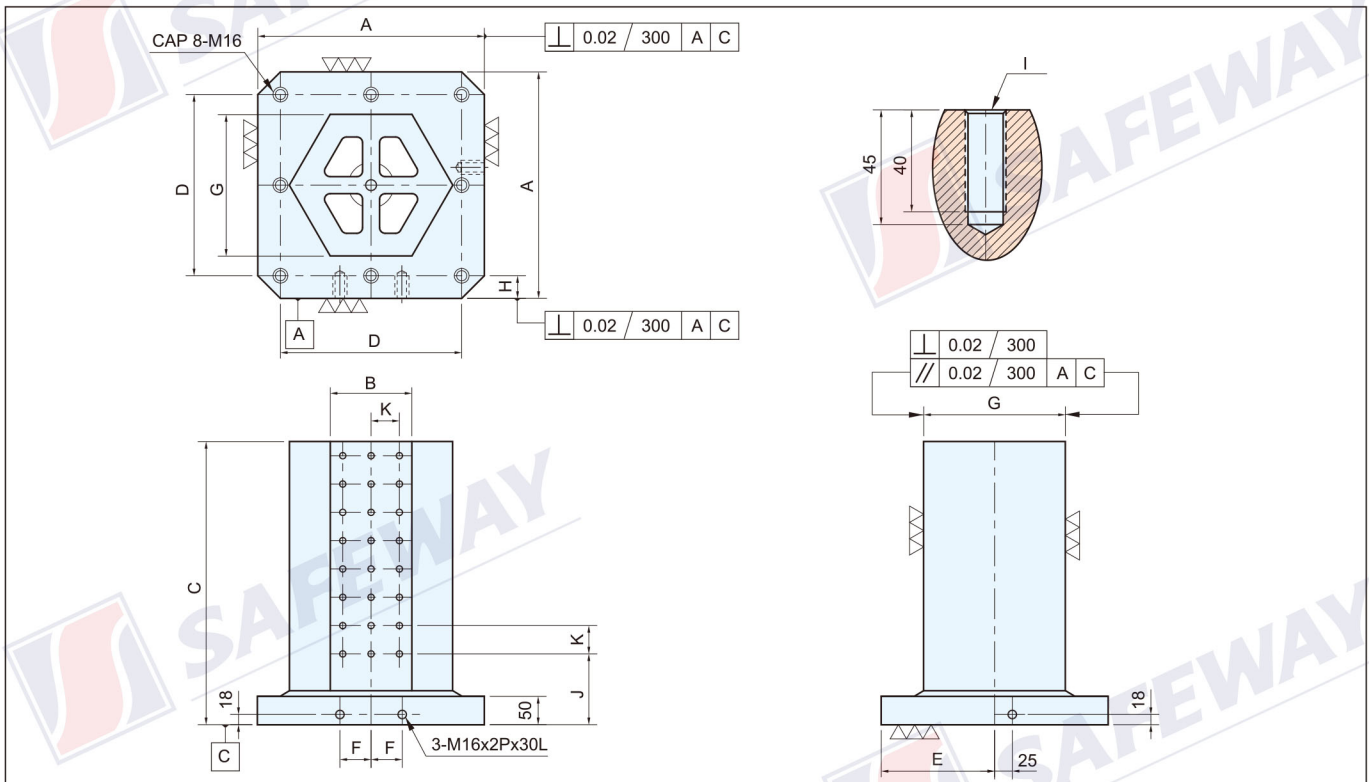

SJB-10

Unit: mm

Order NO. 訂購編號	Model 型號	A	B	C	D	E	F	G	H	I	J	K	N.W. 淨重	Remark 備註
07889202	SJB-400×144×550K6	400	144	550	320	200	55	250	40	12	150	50		
07889204	SJB-400×144×650K6	400	144	650	320	200	55	250	40	12	150	50		
07889206	SJB-500×173×650K6	500	173	650	400	250	75	300	50	12	150	50		
07889208	SJB-500×173×750K6	500	173	750	400	250	75	300	50	12	150	50		
07889210	SJB-630×205×750K6	630	205	750	500	315	100	360	65	12	150	50		
07889212	SJB-630×205×850K6	630	205	850	500	315	100	360	65	12	150	50		
07889214	SJB-800×289×850K6	800	289	850	640	400	135	500	80	12	150	50		
07889216	SJB-800×289×1000K6	800	289	1000	640	400	135	500	80	12	150	50		
07889402	SJB-400×144×550M6	400	144	550	320	200	55	250	40	16	150	50		
07889404	SJB-400×144×650M6	400	144	650	320	200	55	250	40	16	150	50		
07889406	SJB-500×173×650M6	500	173	650	400	250	75	300	50	16	150	50		
07889408	SJB-500×173×750M6	500	173	750	400	250	75	300	50	16	150	50		
07889410	SJB-630×205×750M6	630	205	750	500	315	100	360	65	16	150	50		
07889412	SJB-630×205×850M6	630	205	850	500	315	100	360	65	16	150	50		
07889414	SJB-800×289×850M6	800	289	850	640	400	135	500	80	16	150	50		
07889416	SJB-800×289×1000M6	800	289	1000	640	400	135	500	80	16	150	50		



**MC TOOLING BLOCKS (8 FACES)**

**MC 八面基座**

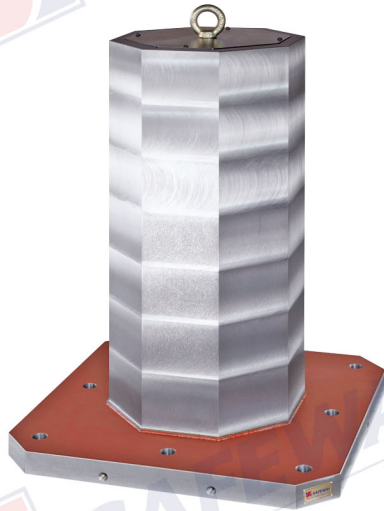

- MODEL • 07890002 SJB-400×103×550N8 • 07890010 SJB-630×149×750N8  
 • 07890004 SJB-400×103×650N8 • 07890012 SJB-630×149×850N8  
 • 07890006 SJB-500×124×650N8 • 07890014 SJB-800×207×850N8  
 • 07890008 SJB-500×124×750N8 • 07890016 SJB-800×207×1000N8

**FEATURES :**

- Material: FCD600~60kgs/mm<sup>2</sup> (80,000psi) ductile iron. (High tensile casting)
- Heat-Treatment-Annealing.
- One piece casting of bed and column.
- Accept special order.

**特性 :**

- 材質：球狀石墨化鑄鐵FCD600~60kgs/mm<sup>2</sup> (80,000psi)
- 燒鈍熱處理。
- 適合臥式綜合切削加工機，重切削加工使用。
- 基座一體成形，剛性佳，適重切削。
- 接受特殊規格訂製，交貨期及價格另議。

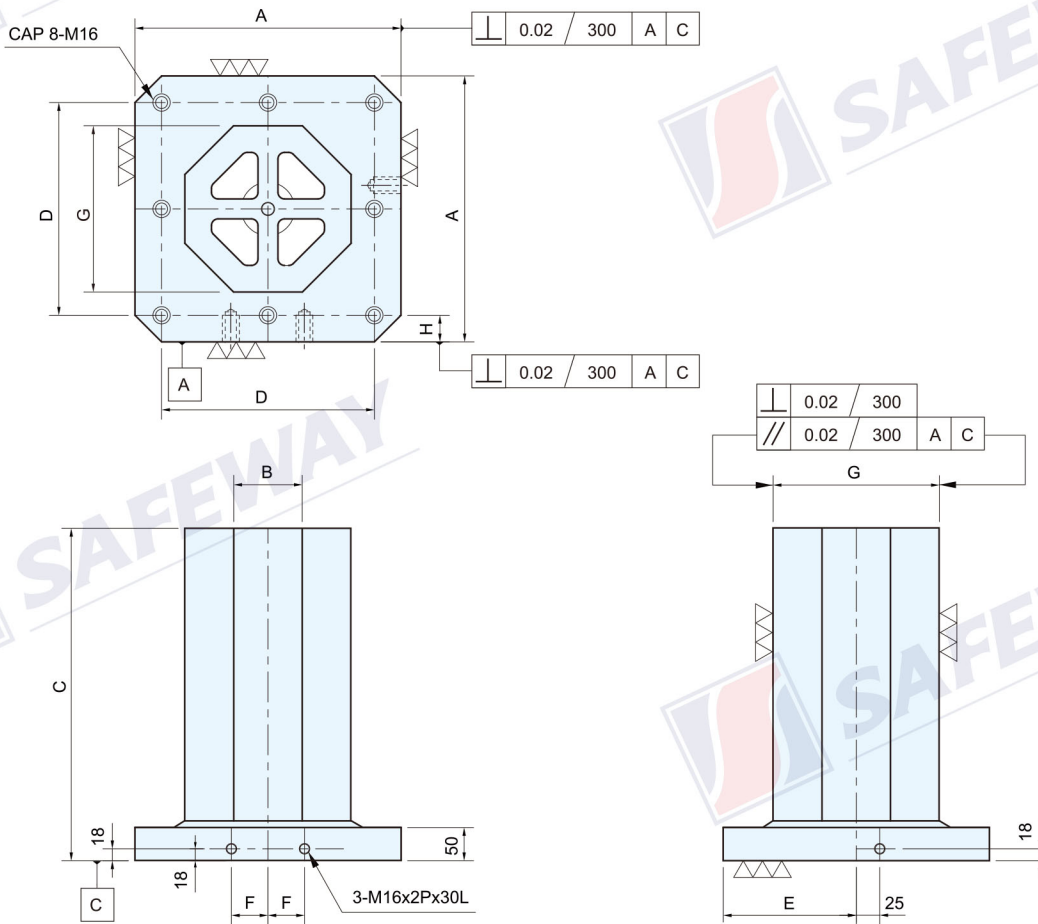

Unit: mm

Order NO. 訂購編號	Model 型號	A	B	C	D	E	F	G	H	N.W. 淨重	Remark 備註
07890002	SJB-400×103×550N8	400	103	550	320	200	55	250	40		
07890004	SJB-400×103×650N8	400	103	650	320	200	55	250	40		
07890006	SJB-500×124×650N8	500	124	650	400	250	75	300	50		
07890008	SJB-500×124×750N8	500	124	750	400	250	75	300	50		
07890010	SJB-630×149×750N8	630	149	750	500	315	100	360	65		
07890012	SJB-630×149×850N8	630	149	850	500	315	100	360	65		
07890014	SJB-800×207×850N8	800	207	850	640	400	135	500	80		
07890016	SJB-800×207×1000N8	800	207	1000	640	400	135	500	80		



**MC TOOLING BLOCKS (8 FACES-TAPPING)**

MC 八面基座 (鑽孔 / 攻牙)

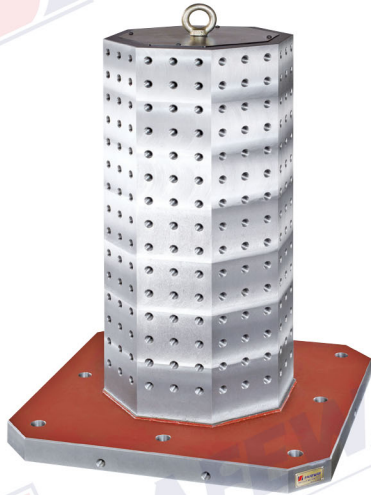

- |       |                               |                               |
|-------|-------------------------------|-------------------------------|
| MODEL | • 07890202 SJB-400×103×550P8  | • 07890402 SJB-400×103×550R8  |
|       | • 07890204 SJB-400×103×650P8  | • 07890404 SJB-400×103×650R8  |
|       | • 07890206 SJB-500×124×650P8  | • 07890406 SJB-500×124×650R8  |
|       | • 07890208 SJB-500×124×750P8  | • 07890408 SJB-500×124×750R8  |
|       | • 07890210 SJB-630×149×750P8  | • 07890410 SJB-630×149×750R8  |
|       | • 07890212 SJB-630×149×850P8  | • 07890412 SJB-630×149×850R8  |
|       | • 07890214 SJB-800×207×850P8  | • 07890414 SJB-800×207×850R8  |
|       | • 07890216 SJB-800×207×1000P8 | • 07890416 SJB-800×207×1000R8 |

**FEATURES :**

- Material: FCD600~60kgs/mm<sup>2</sup> (80,000psi) ductile iron. (High tensile casting)
- Heat-Treatment-Annealing.
- One piece casting of bed and column.
- Accept special order.

**特性 :**

- 材質：球狀石墨化鑄鐵FCD600~60kgs/mm<sup>2</sup> (80,000psi)
- 燒鈍熱處理。
- 適合臥式綜合切削加工機，重切削加工使用。
- 基座一體成形，剛性佳，適重切削。
- 接受特殊規格訂製，交貨期及價格另議。

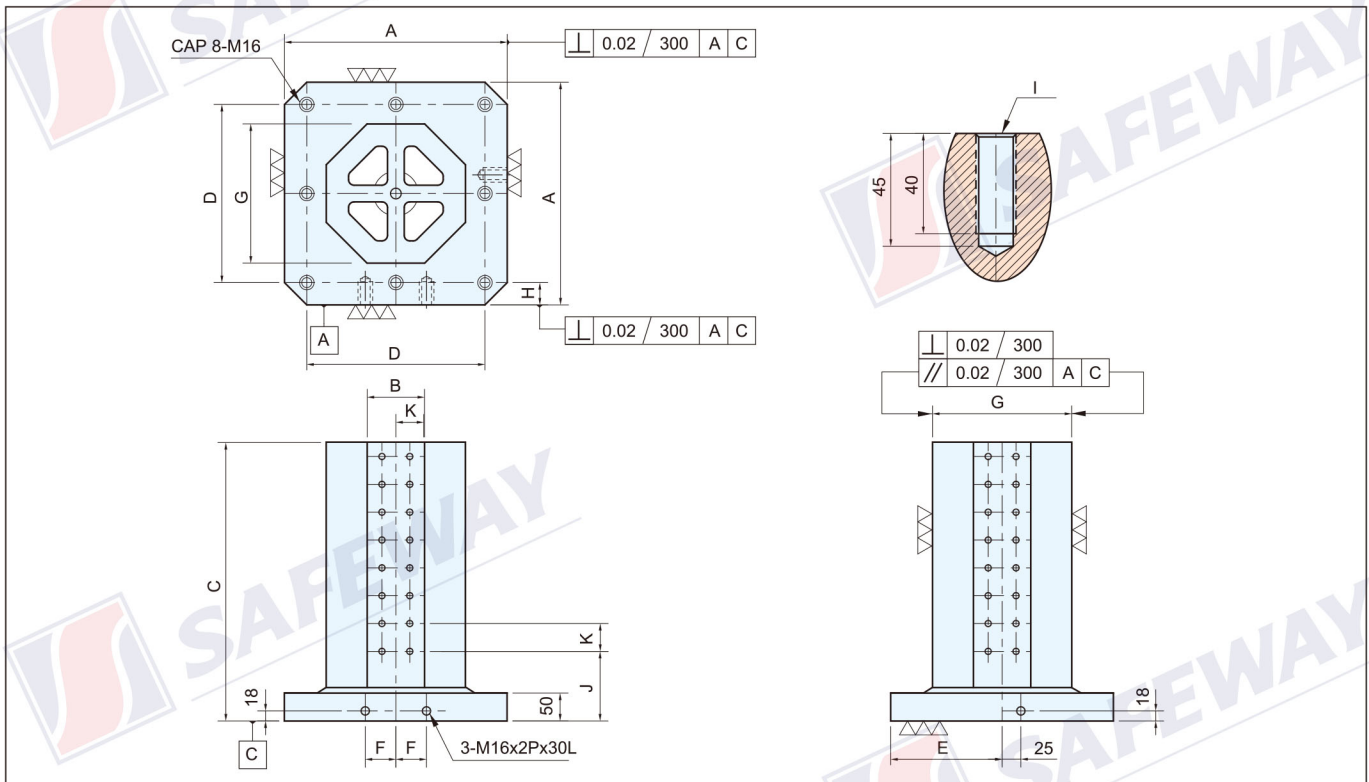

Unit: mm

Order NO. 訂購編號	Model 型號	A	B	C	D	E	F	G	H	I	J	K	N.W. 淨重	Remark 備註
07890202	SJB-400×103×550P8	400	103	550	320	200	55	250	40	12	150	50		
07890204	SJB-400×103×650P8	400	103	650	320	200	55	250	40	12	150	50		
07890206	SJB-500×124×650P8	500	124	650	400	250	75	300	50	12	150	50		
07890208	SJB-500×124×750P8	500	124	750	400	250	75	300	50	12	150	50		
07890210	SJB-630×149×750P8	630	149	750	500	315	100	360	65	12	150	50		
07890212	SJB-630×149×850P8	630	149	850	500	315	100	360	65	12	150	50		
07890214	SJB-800×207×850P8	800	207	850	640	400	135	500	80	12	150	50		
07890216	SJB-800×207×1000P8	800	207	1000	640	400	135	500	80	12	150	50		
07890402	SJB-400×103×550R8	400	103	550	320	200	55	250	40	16	150	50		
07890404	SJB-400×103×650R8	400	103	650	320	200	55	250	40	16	150	50		
07890406	SJB-500×124×650R8	500	124	650	400	250	75	300	50	16	150	50		
07890408	SJB-500×124×750R8	500	124	750	400	250	75	300	50	16	150	50		
07890410	SJB-630×149×750R8	630	149	750	500	315	100	360	65	16	150	50		
07890412	SJB-630×149×850R8	630	149	850	500	315	100	360	65	16	150	50		
07890414	SJB-800×207×850R8	800	207	850	640	400	135	500	80	16	150	50		
07890416	SJB-800×207×1000R8	800	207	1000	640	400	135	500	80	16	150	50		



MC TOOLING ANGLE PLATE  
MC 直角基座



- MODEL
- 07892002 SJB-300×300×220AL
  - 07892004 SJB-400×400×280AL
  - 07892006 SJB-500×500×340AL
  - 07892008 SJB-630×630×450AL
  - 07892010 SJB-800×800×550AL

FEATURES :

- Material: FCD600~60kgs/mm<sup>2</sup> ductile iron. (High tensile casting)
- Heat-Treatment-Annealing.
- One piece casting of bed and column.
- Accept special order.

特性：

- 材質：球狀石墨化鑄鐵FCD600~60kgs/mm<sup>2</sup>
- 燒鈍熱處理。
- 適合臥式綜合切削加工機，重切削加工使用。
- 基座一體成形，剛性佳，適重切削。
- 接受特殊規格訂製，交貨期及價格另議。

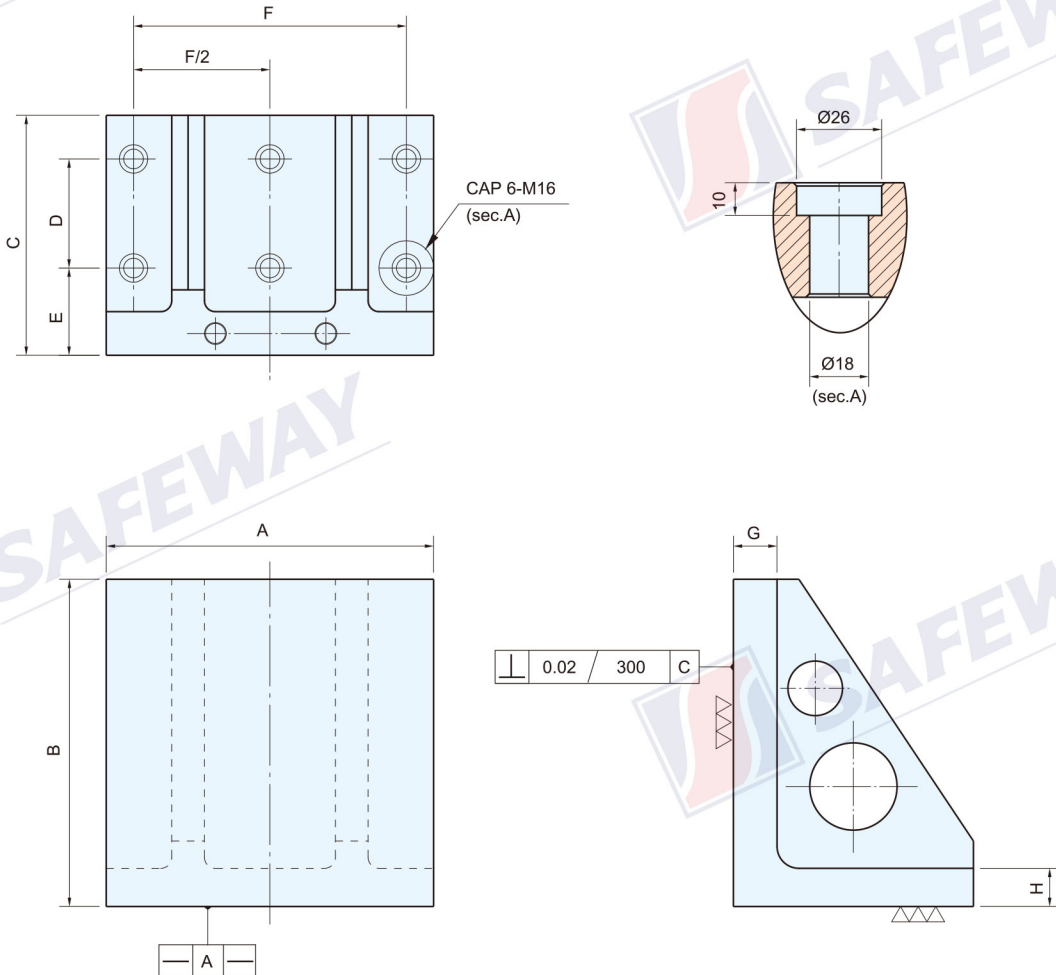

SJB-13

Unit: mm

Order NO. 訂購編號	Model 型號	A	B	C	D	E	F	G	H	N.W. 淨重	Remark 備註
07892002	SJB-300×300×220AL	300	300	220	100	80	240	50	30		
07892004	SJB-400×400×280AL	400	400	280	160	80	320	55	35		
07892006	SJB-500×500×340AL	500	500	340	200	80	400	55	40		
07892008	SJB-630×630×450AL	630	630	450	250	135	500	55	45		
07892010	SJB-800×800×550AL	800	800	550	320	150	640	65	50		





**MC TOOLING ANGLE PLATE (TAPPING)**

MC 直角基座 (鑽孔 / 攻牙)

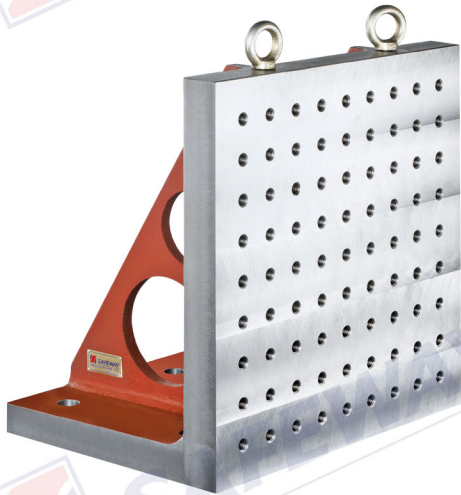

- MODEL
- 07892202 SJB-300×300×220BL
  - 07892402 SJB-300×300×220CL
  - 07892204 SJB-400×400×280BL
  - 07892404 SJB-400×400×280CL
  - 07892206 SJB-500×500×340BL
  - 07892406 SJB-500×500×340CL
  - 07892208 SJB-630×630×450BL
  - 07892408 SJB-630×630×450CL
  - 07892210 SJB-800×800×550BL
  - 07892410 SJB-800×800×550CL

**FEATURES :**

- Material: FCD600~60kgs/mm<sup>2</sup> ductile iron. (High tensile casting)
- Heat-Treatment-Annealing.
- One piece casting of bed and column.
- Accept special order.

**特性 :**

- 材質：球狀石墨化鑄鐵FCD600~60kgs/mm<sup>2</sup>
- 燒鈍熱處理。
- 適合臥式綜合切削加工機，重切削加工使用。
- 基座一體成形，剛性佳，適重切削。
- 接受特殊規格訂製，交貨期及價格另議。

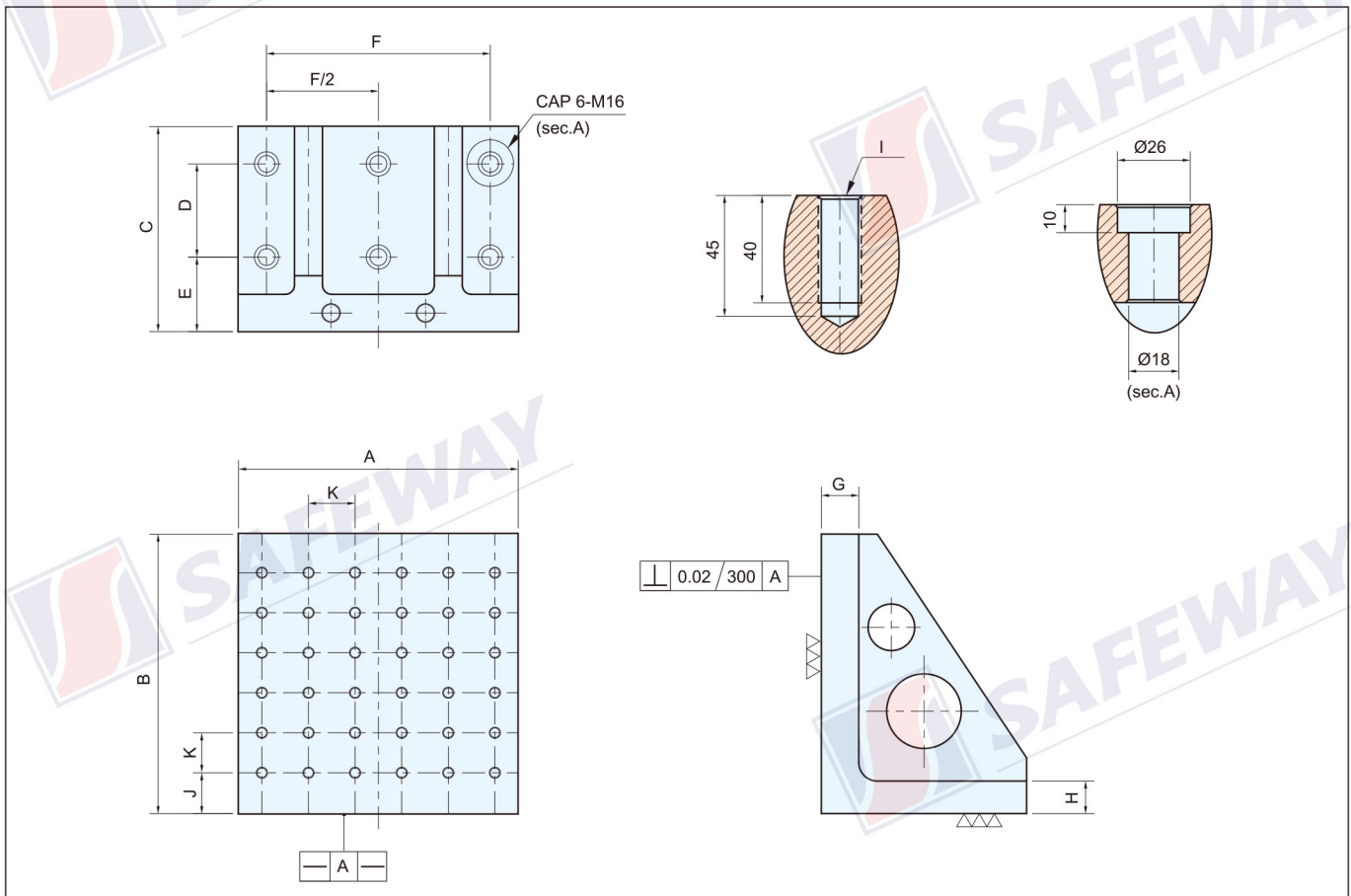

Unit: mm

Order NO. 訂購編號	Model 型號	A	B	C	D	E	F	G	H	I	J	K	N.W. 淨重	Remark 備註
07892202	SJB-300×300×220BL	300	300	220	100	80	240	50	30	12	75	50		
07892204	SJB-400×400×280BL	400	400	280	160	80	320	55	35	12	75	50		
07892206	SJB-500×500×340BL	500	500	340	200	80	400	55	40	12	75	50		
07892208	SJB-630×630×450BL	630	630	450	250	135	500	55	45	12	105	50		
07892210	SJB-800×800×550BL	800	800	550	320	150	640	65	50	12	125	50		
07892402	SJB-300×300×220CL	300	300	220	100	80	240	50	30	16	75	50		
07892404	SJB-400×400×280CL	400	400	280	160	80	320	55	35	16	75	50		
07892406	SJB-500×500×340CL	500	500	340	200	80	400	55	40	16	75	50		
07892408	SJB-630×630×450CL	630	630	450	250	135	500	55	45	16	105	50		
07892410	SJB-800×800×550CL	800	800	550	320	150	640	65	50	16	125	50		



**MC TOOLING ANGLE PLATE (T-SLOTS)**

**MC 直角基座 (T型槽)**

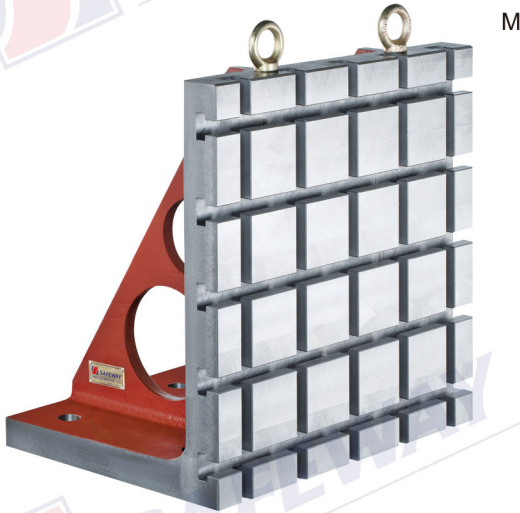

- MODEL • 07892602 SJB-300×300×220DL • 07892802 SJB-300×300×220EL  
 • 07892604 SJB-400×400×280DL • 07892804 SJB-400×400×280EL  
 • 07892606 SJB-500×500×340DL • 07892806 SJB-500×500×340EL  
 • 07892608 SJB-630×630×450DL • 07892808 SJB-630×630×450EL  
 • 07892610 SJB-800×800×550DL • 07892810 SJB-800×800×550EL

**FEATURES :**

- Material: FCD600~60kgs/mm<sup>2</sup> ductile iron. (High tensile casting)
- Heat-Treatment-Annealing.
- One piece casting of bed and column.
- Accept special order.

**特性 :**

- 材質：球狀石墨化鑄鐵FCD600~60kgs/mm<sup>2</sup>
- 燒鈍熱處理。
- 適合臥式綜合切削加工機，重切削加工使用。
- 基座一體成形，剛性佳，適重切削。
- 接受特殊規格訂製，交貨期及價格另議。

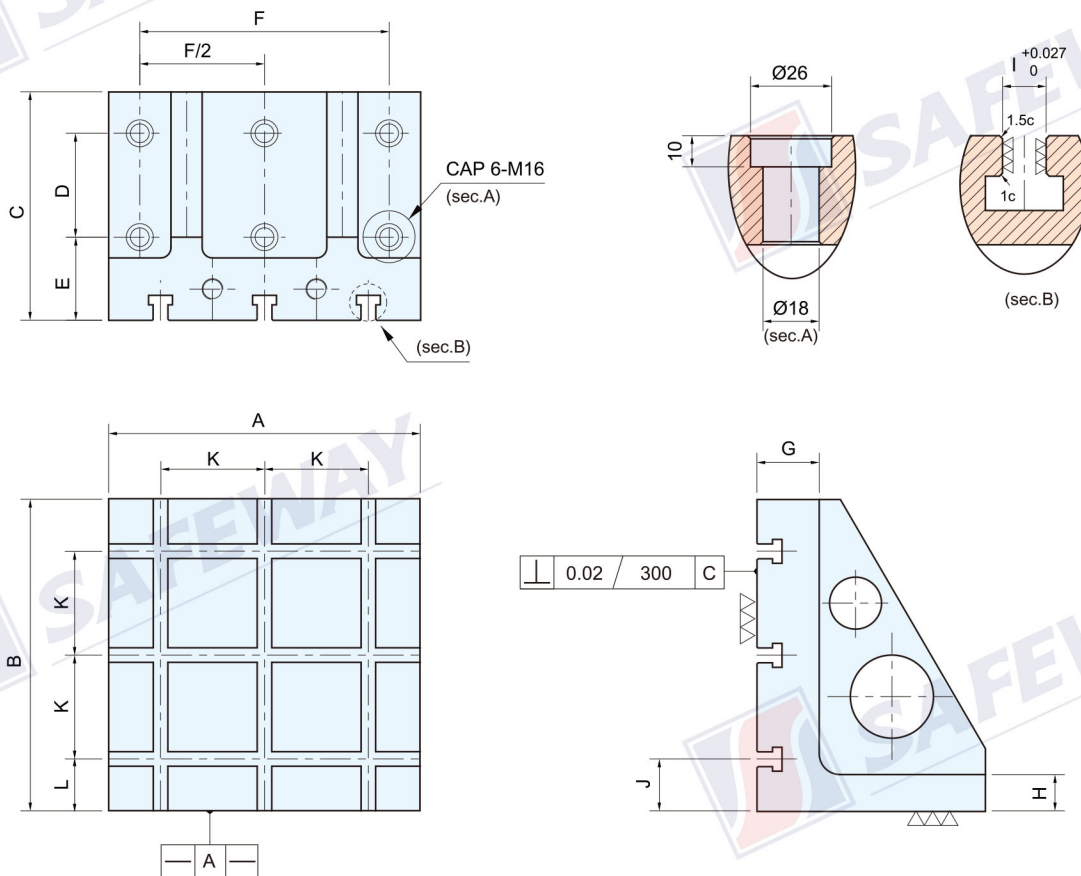

Unit: mm

Order NO. 訂購編號	Model 型號	A	B	C	D	E	F	G	H	I	J	K	L	N.W. 淨重	Remark 備註
07892602	SJB-300×300×220DL	300	300	220	100	80	240	60	35	14	50	100	50		
07892604	SJB-400×400×280DL	400	400	280	160	80	320	60	40	14	50	100	50		
07892606	SJB-500×500×340DL	500	500	340	200	80	400	60	45	14	50	100	50		
07892608	SJB-630×630×450DL	630	630	450	250	135	500	65	50	14	65	125	65		
07892610	SJB-800×800×550DL	800	800	550	320	150	640	75	55	14	100	150	105		
07892802	SJB-300×300×220EL	300	300	220	100	80	240	60	35	18	50	100	50		
07892804	SJB-400×400×280EL	400	400	280	160	80	320	60	40	18	50	100	50		
07892806	SJB-500×500×340EL	500	500	340	200	80	400	60	45	18	50	100	50		
07892808	SJB-630×630×450EL	630	630	450	250	135	500	65	50	18	65	125	65		
07892810	SJB-800×800×550EL	800	800	550	320	150	640	75	55	18	100	150	105		



**MC TOOLING ANGLE PLATE**

**MC 直角基座**



- MODEL • 07894002 SJB-100×300×200FL • 07894012 SJB-160×500×280FL  
 • 07894004 SJB-100×400×250FL • 07894014 SJB-200×300×200FL  
 • 07894006 SJB-100×500×280FL • 07894016 SJB-200×400×250FL  
 • 07894008 SJB-160×300×200FL • 07894018 SJB-200×500×280FL  
 • 07894010 SJB-160×400×250FL

**FEATURES :**

- Material: FCD600~60kgs/mm<sup>2</sup> ductile iron. (High tensile casting)
- Heat-Treatment-Annealing.
- One piece casting of bed and column.
- Accept special order.

**特性：**

- 材質：球狀石墨化鑄鐵FCD600~60kgs/mm<sup>2</sup>
- 燒鈍熱處理。
- 適合臥式綜合切削加工機，重切削加工使用。
- 基座一體成形，剛性佳，適重切削。
- 接受特殊規格訂製，交貨期及價格另議。

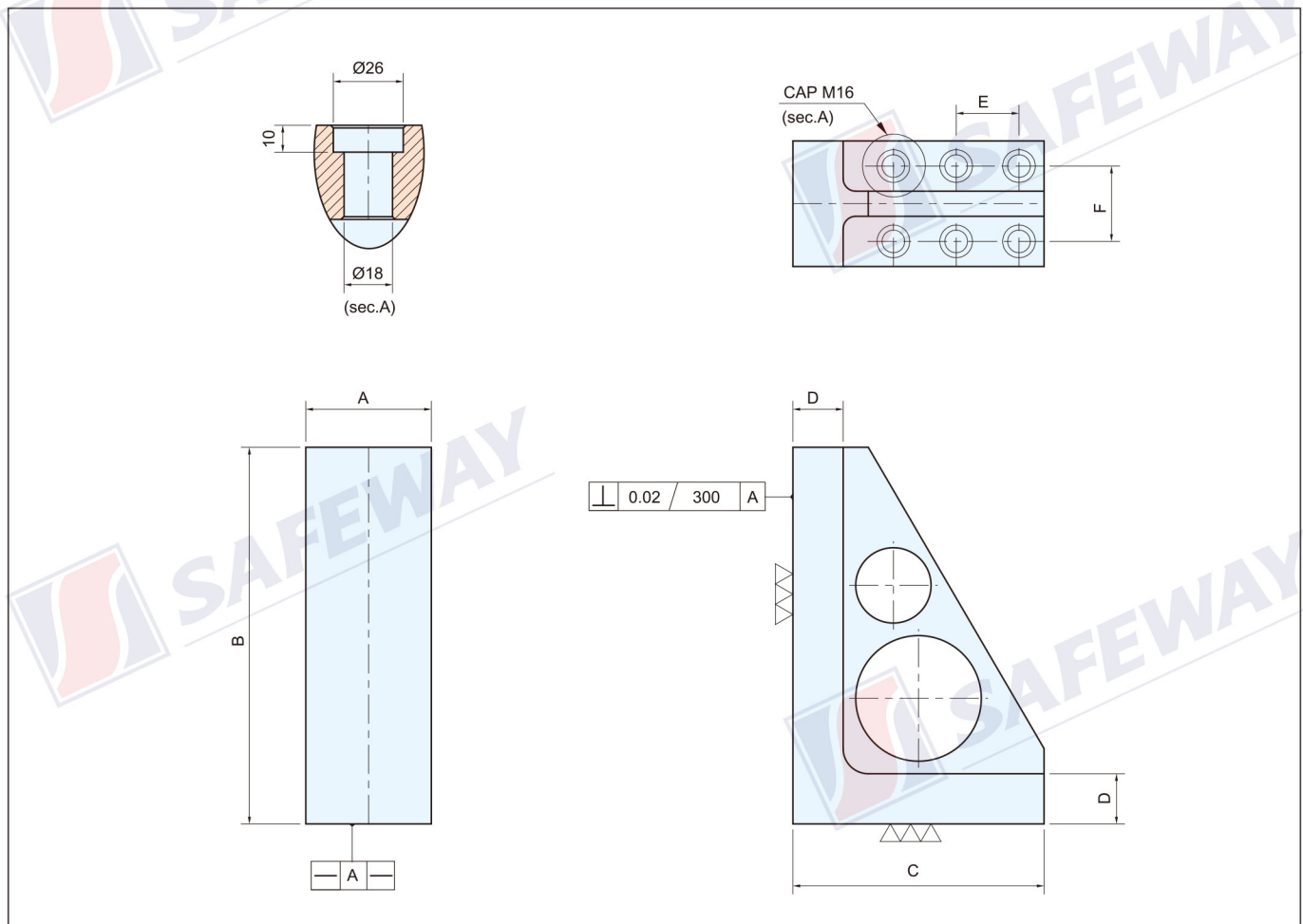

Unit: mm

Order NO. 訂購編號	Model 型號	A	B	C	D	E	F	N.W. 淨重	Remark 備註
07894002	SJB-100×300×200FL	100	300	200	40	50	50		
07894004	SJB-100×400×250FL	100	400	250	40	50	50		
07894006	SJB-100×500×280FL	100	500	280	40	50	50		
07894008	SJB-160×300×200FL	160	300	200	40	50	100		
07894010	SJB-160×400×250FL	160	400	250	40	50	100		
07894012	SJB-160×500×280FL	160	500	280	40	50	100		
07894014	SJB-200×300×200FL	200	300	200	40	50	100		
07894016	SJB-200×400×250FL	200	400	250	40	50	100		
07894018	SJB-200×500×280FL	200	500	280	40	50	100		



**MC TOOLING ANGLE PLATE (TAPPING)**

**MC直角基座(鑽孔 / 攻牙)**



- |       |                              |                              |
|-------|------------------------------|------------------------------|
| MODEL | • 07894202 SJB-100×300×200GL | • 07894402 SJB-100×300×200HL |
|       | • 07894204 SJB-100×400×250GL | • 07894404 SJB-100×400×250HL |
|       | • 07894206 SJB-100×500×280GL | • 07894406 SJB-100×500×280HL |
|       | • 07894208 SJB-160×300×200GL | • 07894408 SJB-160×300×200HL |
|       | • 07894210 SJB-160×400×250GL | • 07894410 SJB-160×400×250HL |
|       | • 07894212 SJB-160×500×280GL | • 07894412 SJB-160×500×280HL |
|       | • 07894214 SJB-200×300×200GL | • 07894414 SJB-200×300×200HL |
|       | • 07894216 SJB-200×400×250GL | • 07894416 SJB-200×400×250HL |
|       | • 07894218 SJB-200×500×280GL | • 07894418 SJB-200×500×280HL |

**FEATURES :**

- Material: FCD600~60kgs/mm<sup>2</sup> ductile iron. (High tensile casting)
- Heat-Treatment-Annealing.
- One piece casting of bed and column.
- Accept special order.

**特性 :**

- 材質：球狀石墨化鑄鐵FCD600~60kgs/mm<sup>2</sup>
- 燒鈍熱處理。
- 適合臥式綜合切削加工機，重切削加工使用。
- 基座一體成形，剛性佳，適重切削。
- 接受特殊規格訂製，交貨期及價格另議。

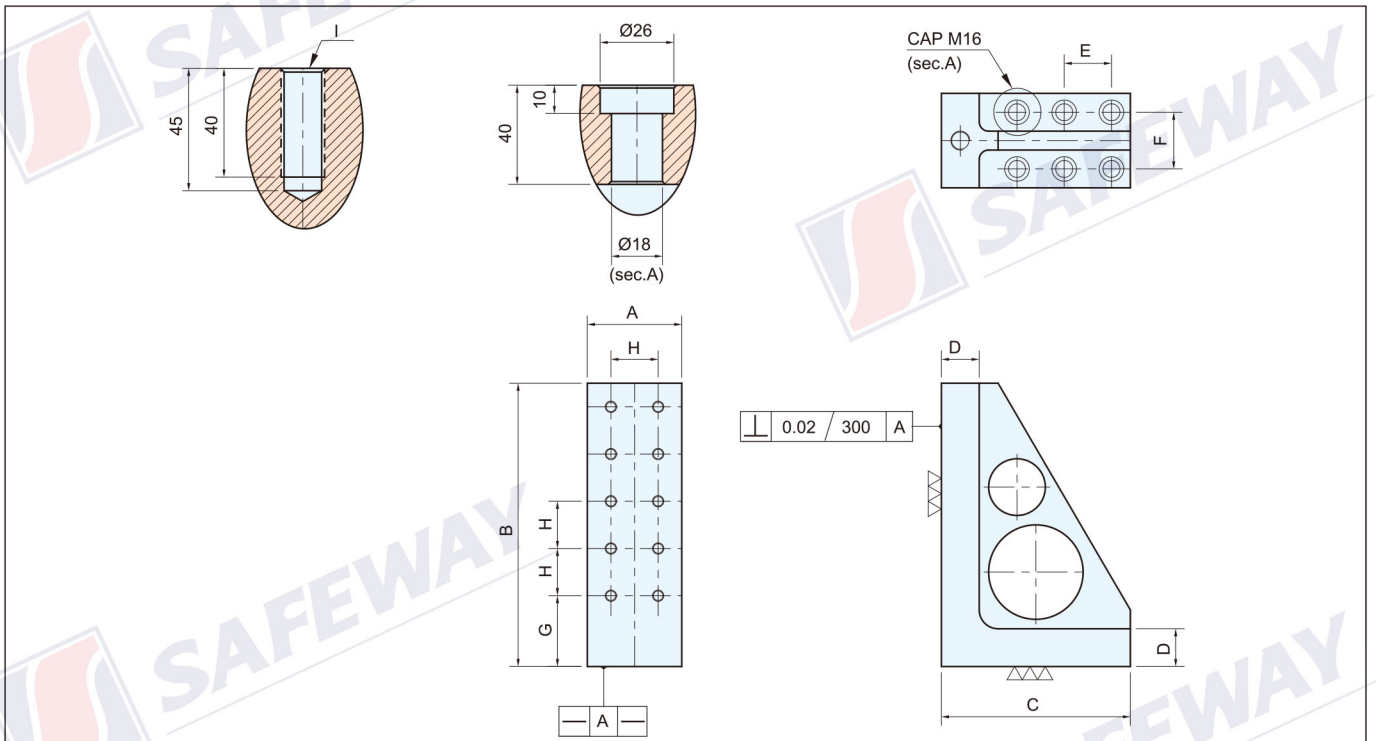

Unit: mm

Order NO. 訂購編號	Model 型號	A	B	C	D	E	F	G	H	I	N.W. 淨重	Remark 備註
07894202	SJB-100×300×200GL	100	300	200	40	50	50	75	50	12		
07894204	SJB-100×400×250GL	100	400	250	40	50	50	75	50	12		
07894206	SJB-100×500×280GL	100	500	280	40	50	50	75	50	12		
07894208	SJB-160×300×200GL	160	300	200	40	50	100	75	50	12		
07894210	SJB-160×400×250GL	160	400	250	40	50	100	75	50	12		
07894212	SJB-160×500×280GL	160	500	280	40	50	100	75	50	12		
07894214	SJB-200×300×200GL	200	300	200	40	50	100	75	50	12		
07894216	SJB-200×400×250GL	200	400	250	40	50	100	75	50	12		
07894218	SJB-200×500×280GL	200	500	280	40	50	100	75	50	12		
07894402	SJB-100×300×200HL	100	300	200	40	50	50	75	50	16		
07894404	SJB-100×400×250HL	100	400	250	40	50	50	75	50	16		
07894406	SJB-100×500×280HL	100	500	280	40	50	50	75	50	16		
07894408	SJB-160×300×200HL	160	300	200	40	50	100	75	50	16		
07894410	SJB-160×400×250HL	160	400	250	40	50	100	75	50	16		
07894412	SJB-160×500×280HL	160	500	280	40	50	100	75	50	16		
07894414	SJB-200×300×200HL	200	300	200	40	50	100	75	50	16		
07894416	SJB-200×400×250HL	200	400	250	40	50	100	75	50	16		
07894418	SJB-200×500×280HL	200	500	280	40	50	100	75	50	16		



**MC TOOLING BLOCKS (RECTANGULAR TYPE-TAPPING)**

MC 方型墊塊 (鑽孔 / 攻牙)

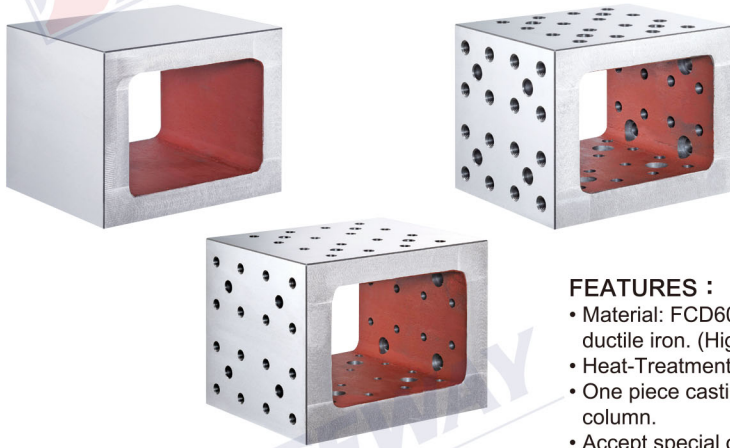

- MODEL
- 07896002 SJB-150×200×150V4
  - 07896004 SJB-200×250×200V4
  - 07896006 SJB-250×300×250V4
  - 07896202 SJB-150×200×150Y4
  - 07896204 SJB-200×250×200Y4
  - 07896206 SJB-250×300×250Y4
  - 07896404 SJB-150×200×150Z4
  - 07896406 SJB-200×250×200Z4
  - 07896408 SJB-250×300×250Z4

**FEATURES :**

- Material: FCD600~60kgs/mm<sup>2</sup> ductile iron. (High tensile casting)
- Heat-Treatment-Annealing.
- One piece casting of bed and column.
- Accept special order.

**特性 :**

- 材質：球狀石墨化鑄鐵FCD600~60kgs/mm<sup>2</sup> 燒鈍熱處理。
- 適合臥式綜合切削加工機，重切削加工使用。
- 墊塊一體成形，剛性佳，適重切削。
- 接受特殊規格訂製，交貨期及價格另議。

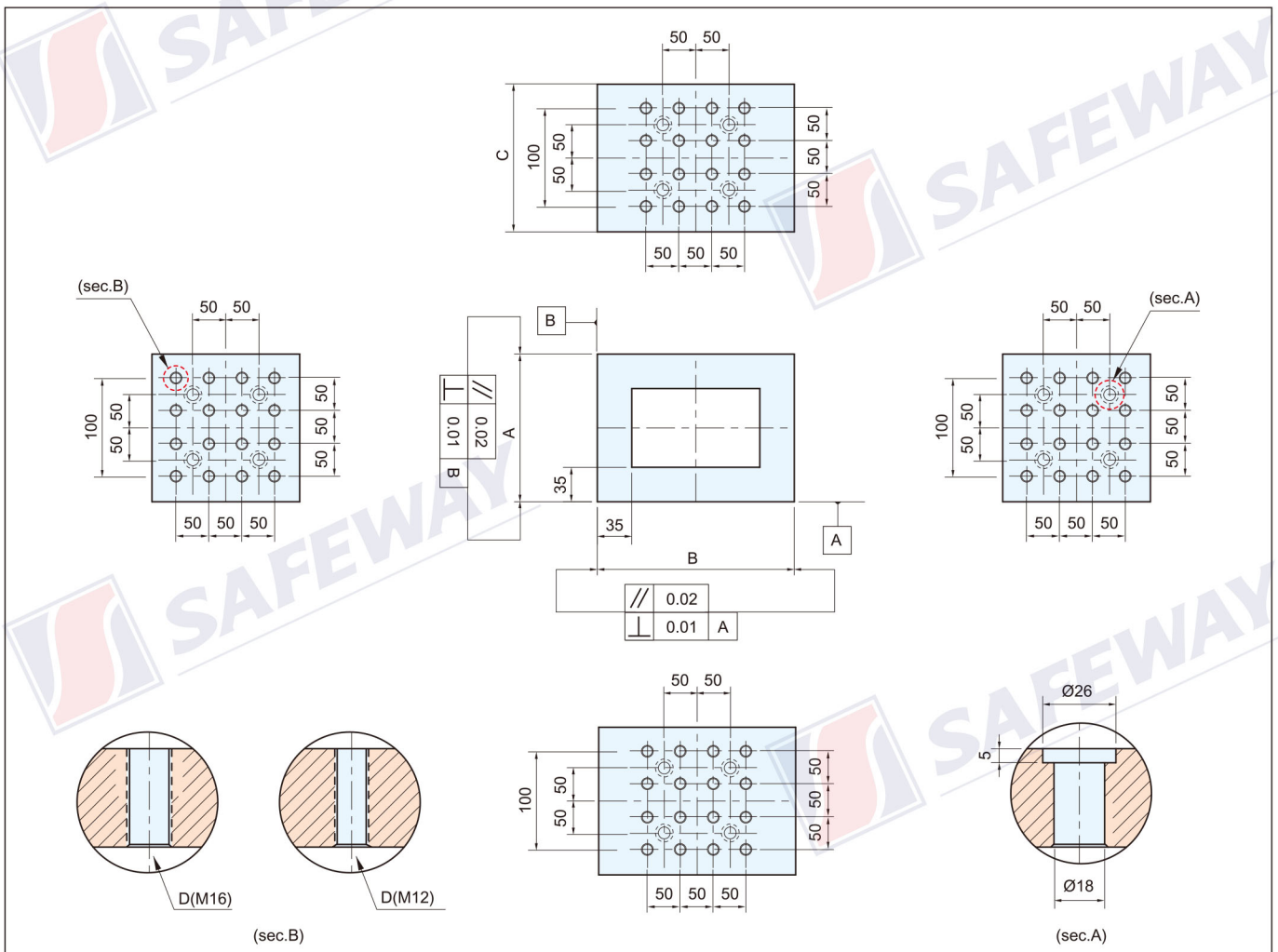

Unit: mm

Order NO. 訂購編號	Model 型號	A	B	C	D	N.W. 淨重	Remark 備註
07896002	SJB-150×200×150V4	150	200	150			
07896004	SJB-200×250×200V4	200	250	200			
07896006	SJB-250×300×250V4	250	300	250			
07896202	SJB-150×200×150Y4	150	200	150	M12		
07896204	SJB-200×250×200Y4	200	250	200	M12		
07896206	SJB-250×300×250Y4	250	300	250	M12		
07896404	SJB-150×200×150Z4	150	200	150	M16		
07896406	SJB-200×250×200Z4	200	250	200	M16		
07896408	SJB-250×300×250Z4	250	300	250	M16		