

MC 定壓式倍力虎鉗(特大開口) / MC 精密機械式虎鉗(大開口)
 MC POWER VISE (LONG OPENING) /
 MC MECHANICAL VISE(LONG OPENING)

MODEL : JQV-160L, 160XL, 160LL, 200XL, 200LL
 JMV-160L, 160XL, 160LL, 200XL, 200LL



特點：

1. 定壓裝置，夾持力可以預先設定，重複使用相同的夾持力。
2. 虎鉗本台採用球狀石墨化鑄鐵FCD-60材質。
3. 虎鉗滑動面均經硬化熱處理HRC45°，堅固耐用確保精度。
4. 虎鉗本體的高度與導正鍵槽皆做定寸管制，可以2、3、4台一起使用。
5. 虎鉗本體長度超短，開口超大，適合各式銑床、中心加工機使用。

FEATURES :

1. Pressure Constant. Clamping force can presetting, repeat use the same clamping force.
2. Vise body is made of ductile iron FCD-60.
3. Vise bed hardened to HRC45° and maintain accuracy for long.
4. Vise bed height-size and the guide block side are all made with full control, can 2、3、or 4 vises to perform a job at a time.
5. The length of vise body is very short, but the clamping range is very big. It works with every kind of milling machine, CNC machine center...

★ 每台虎鉗的高度與導正鍵槽皆做定寸管制。
 The height and the guide block side of every vise are all made with full control.

L-尺寸公差限度0.02或少於 H- Dimension tolerance 0.02 or less.
 L- Dimension tolerance 0.02 or less.

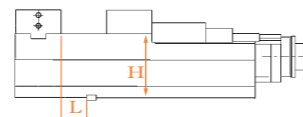

No.	檢查項目 Inspection Item(100mm)	容許值 Allowance	
		JIN YEAR	JIS CLASS
1.	鉗口面對本台底面導正鍵槽之平行度 Parallelism of guide block side of body bottom face and fixed jaw clamp force. 鉗口面對滑動面之垂直度	0.01	0.015
2.	Squareness of fixed jaw clamp face and jaw slide way.	0.015	0.03
3.	雙側面對滑動面之垂直度 Vise side-lock on the bottom with the slide way in vertical.	0.02	0.02
4.	本台滑動面對底面之平行度 Parallelism of body bottom face and jaw slide way.	0.01	0.015
5.	工件夾緊後之上浮量 Top face lift of test block in clamping. 工件夾緊後之平行度	0.015	0.03
6.	Parallelism of top face of clamped test block in clamping.	0.015	0.02

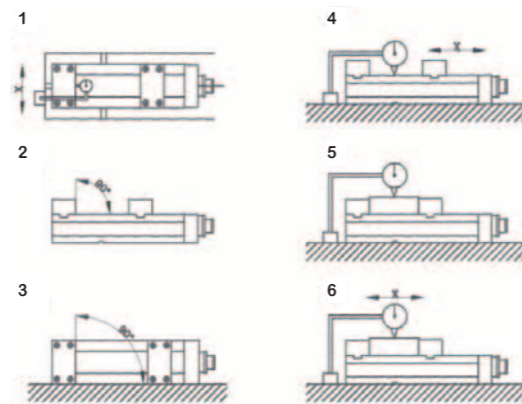

● 定壓裝置：

1. 夾持力可以預先設定，將六角板手插入定壓裝置之缺口，調整至所需要之夾持力刻度，即可重複使用相同的夾持力。
2. 一般最適用的夾持力刻度為 ④
3. Direct 1 刻度是螺桿夾持的力量，沒有切換成倍力增壓系統，適合夾持材質比較軟的工件如鋁或銅等。

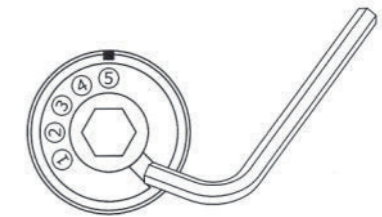

● 定壓裝置
 ● PRESSURE SYSTEM

● PRESSURE SYSTEM :

1. Clamping force can be set up in advance, using hexagon wrench to insert into the gap of pressure system. Then, it can be adjusted to the clamping force for specific demand and allowed to repeat use the same clamping force.
2. Generally clamping force is suitable scale ④
3. Scale of Direct 1 is clamping force of spindle, and without shifting power system, so it's suitable for clamping much softer workpiece such as aluminum, copper and so on.

MODEL	夾持力(刻度) Clamping Force (Scale)					開口範圍 Clamping Range
	1	2	3	4	5	
JQV-160L	Direct	2000	3000	4000	5000	0-355
JQV-160XL	Direct	2000	3000	4000	5000	165-520
JQV-160LL	Direct	2000	3000	4000	5000	355-705
JQV-200XL	Direct	2000	3500	4500	6000	205-605
JQV-200LL	Direct	2000	3500	4500	6000	405-805

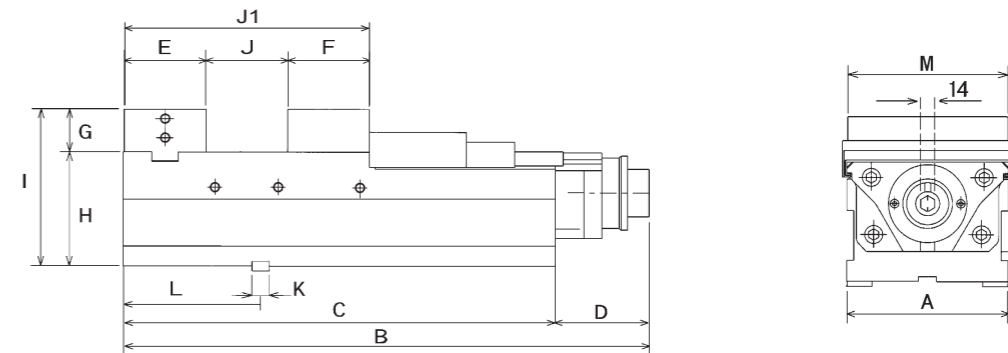
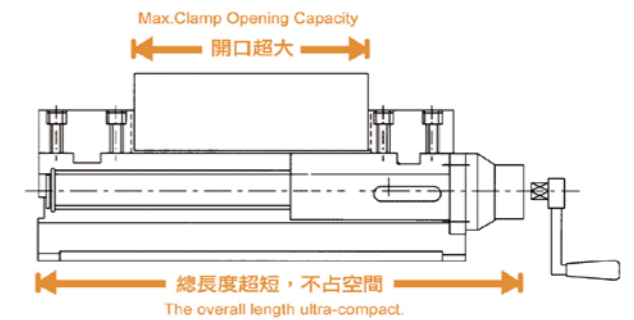

MC 定壓式倍力虎鉗(特大開口) MC POWER VISE (LONG OPENING)

MODEL	A	B	C	D	E	F	G	H	I	J	J1	K	L	M	夾持力 Clamping Force	N.W
JQV-160L	161	635	536	99	94	86	60	100	160	355	535	18	153	159	5000kgf	66kg
JQV-160XL	161	800	701	99	94	86	60	100	160	520	695	18	153	159	5000kgf	78kg
JQV-160LL	161	985	886	99	94	86	60	100	160	705	800	18	153	159	5000kgf	96kg
JQV-200XL	201	910	810	99	102	98	70	110	180	605	800	18	176	199	6000kgf	125kg
JQV-200LL	201	1110	1010	99	102	98	70	110	180	805	1000	18	176	199	6000kgf	147kg

MC精密機械式虎鉗(大開口) MC MECHANICAL VISE(LONG OPENING)

MODEL	A	B	C	D	E	F	G	H	I	J	J1	K	L	M	N.W
JMV-160L	161	635	536	99	94	86	60	100	160	355	535	18	153	159	64kg
JMV-160XL	161	800	701	99	94	86	60	100	160	520	695	18	153	159	76kg
JMV-160LL	161	985	886	99	94	86	60	100	160	705	800	18	153	159	94kg
JMV-200XL	201	910	810	99	102	98	70	110	180	605	800	18	176	199	123kg
JMV-200LL	201	1110	1010	99	102	98	70	110	180	805	1000	18	176	199	145kg