

# HS-450 540 550 Series

Ultimate High Speed Horizontal Machining Center

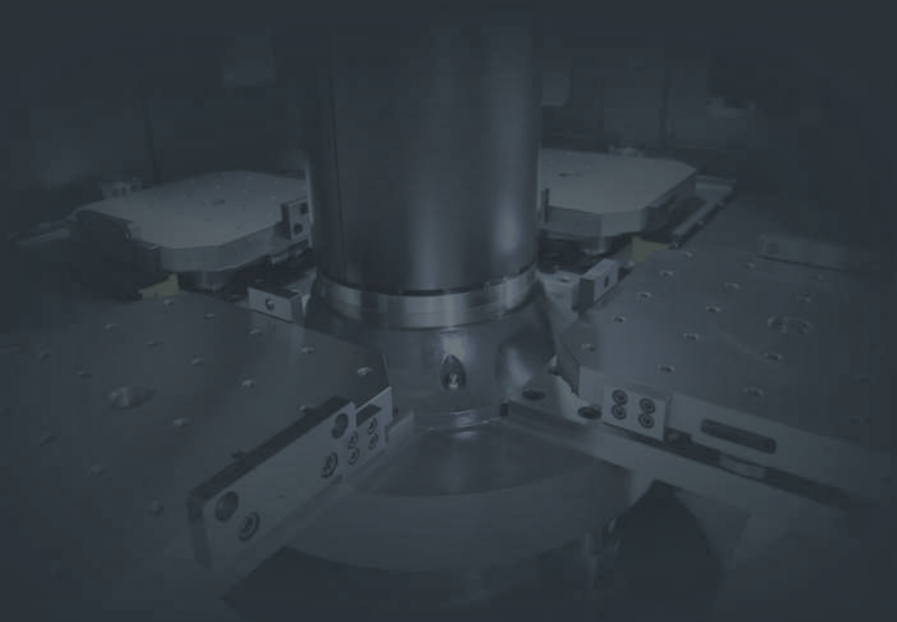

No.63, Industrial Park 35th Rd., Situn Dist., Taichung 40768, Taiwan.  
Tel:+886-4-2355-1899 FAX:+886-4-2350-9977  
www.averexcnc.com E-mail:sales@averexcnc.com



032019 EN



# Rigid Structure

## Standard Features

- AVEREX-FANUC MPro I Controller with Value Packaged Features
- One-piece Stepped Machine Base with Heavy Ribbed
- Three Points Machine Leveling
- 100% Hand-scraping for Geometry Accuracy and Rigidity
- BBT Dual Surface Contact Spindle
- 1° Index Table (Optional 0.001° Full Rotary Table)
- THK® Roller Guide Ways
- TSUBAKI® Ballscrews
- Thermal Stability (Chilled Spindle)
- Pressurized Oil-Air Lubrication Spindle, Ballscrews and Guide Ways
- Mechanical Lock Pallet Clamping System with Air Seal Detection
- Overhead Automatic Pallet Wash System
- 30 Bar Through Spindle Coolant, Prepared for Optional 70 Bar
- Automatic Machine Power On/Off and Warm-up within 7 days

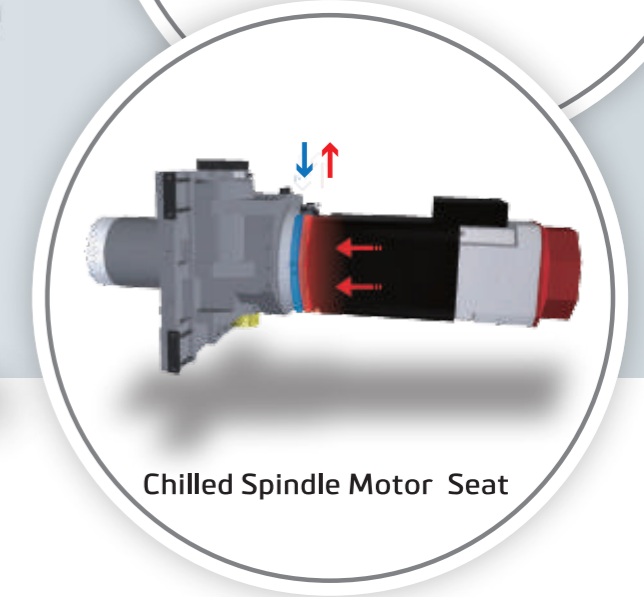
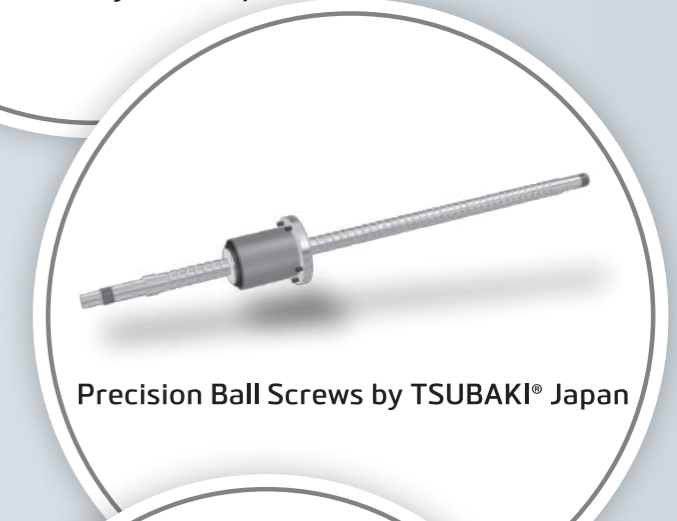
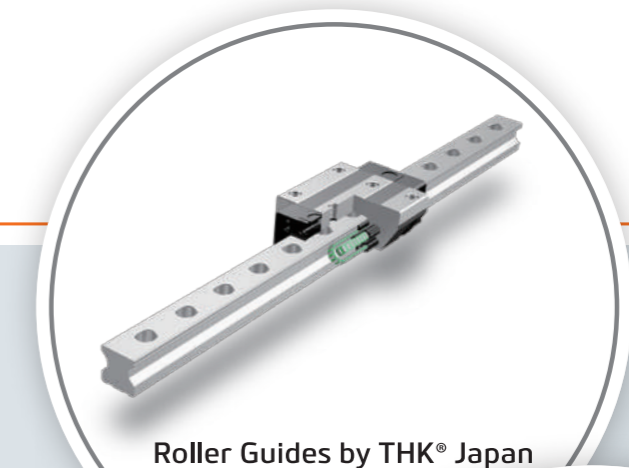
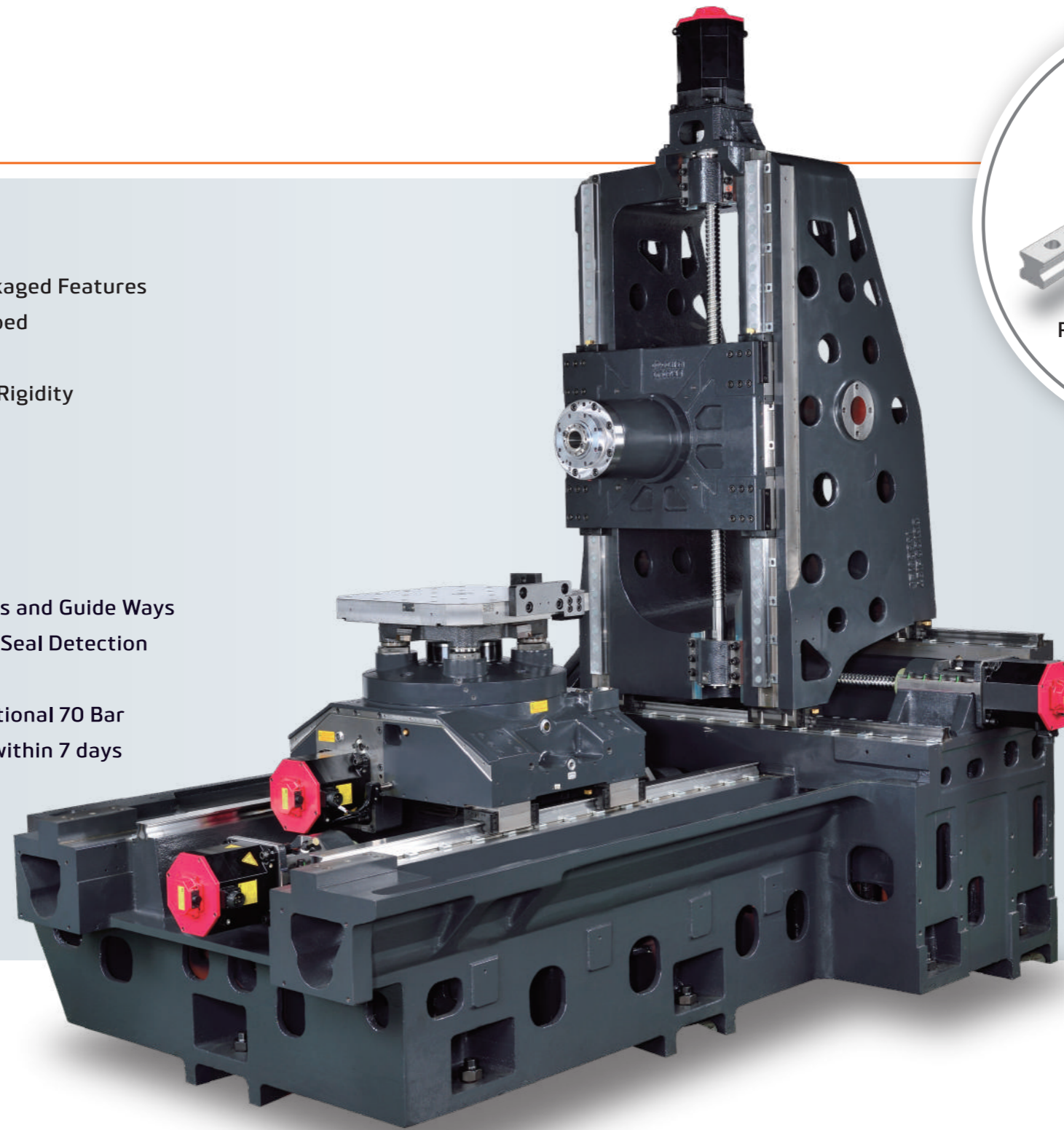

100% Hand-Scraping for Geometry Accuracy and Rigidity

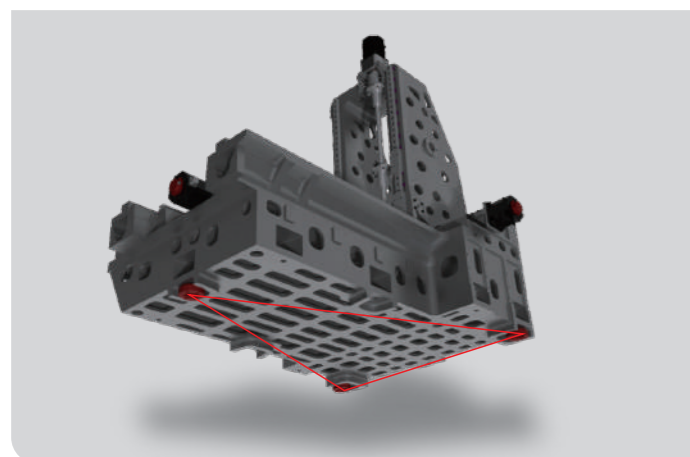

Three Points Machine Leveling

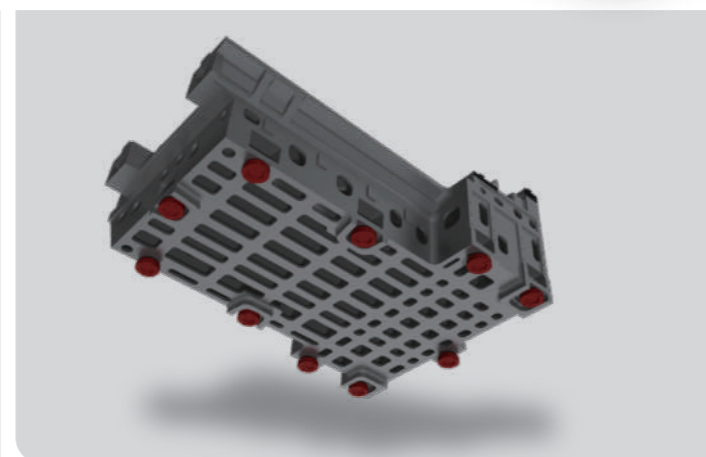

Ten Points Machine Supports

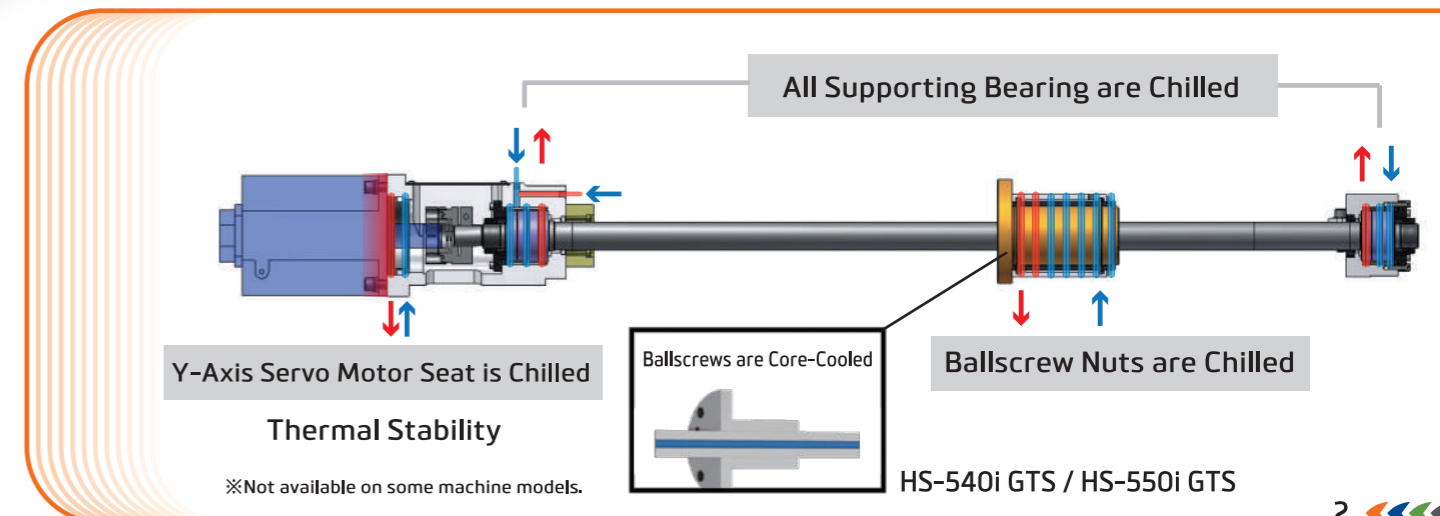

# BBT Dual Surface Contact Spindle

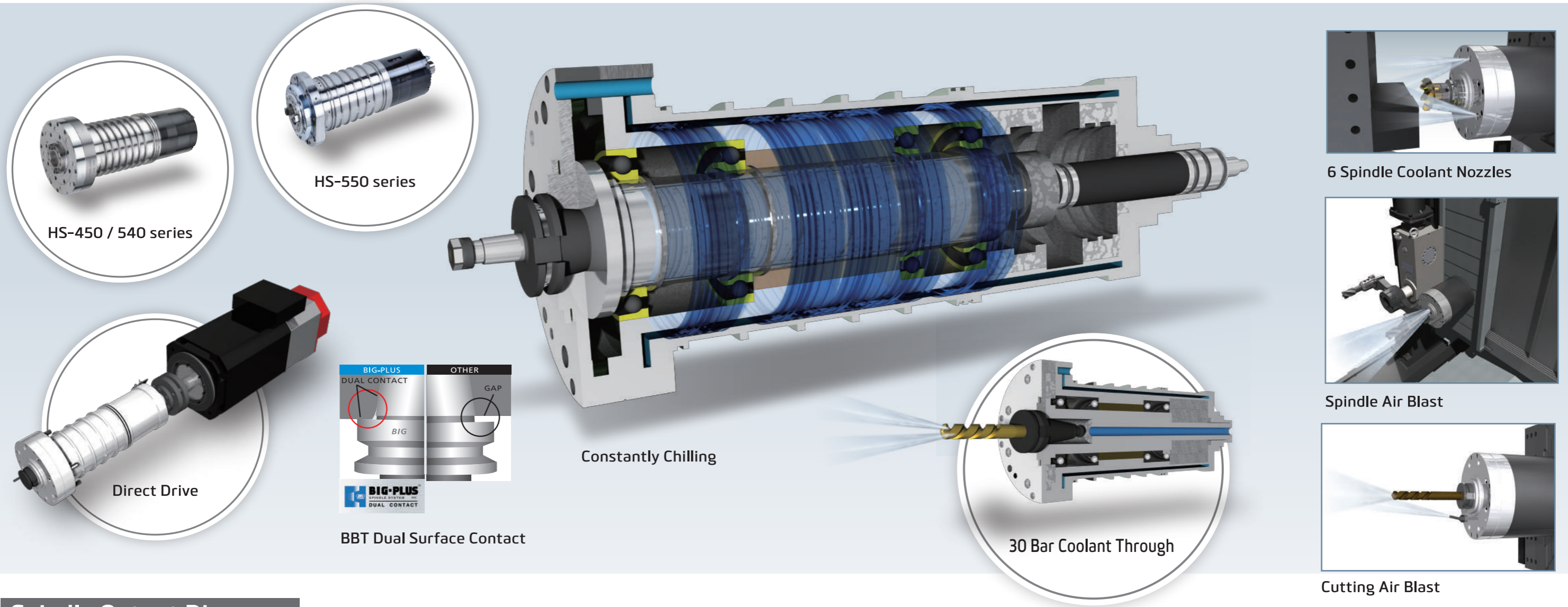

## Spindle Output Diagrams

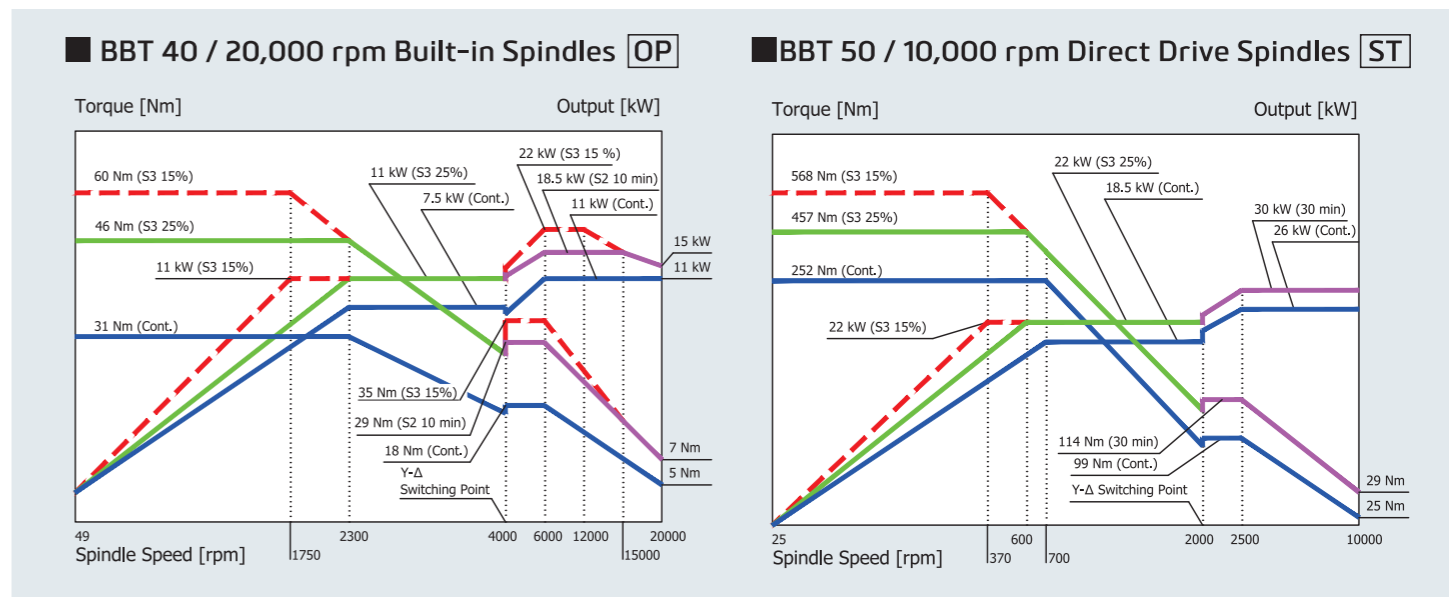
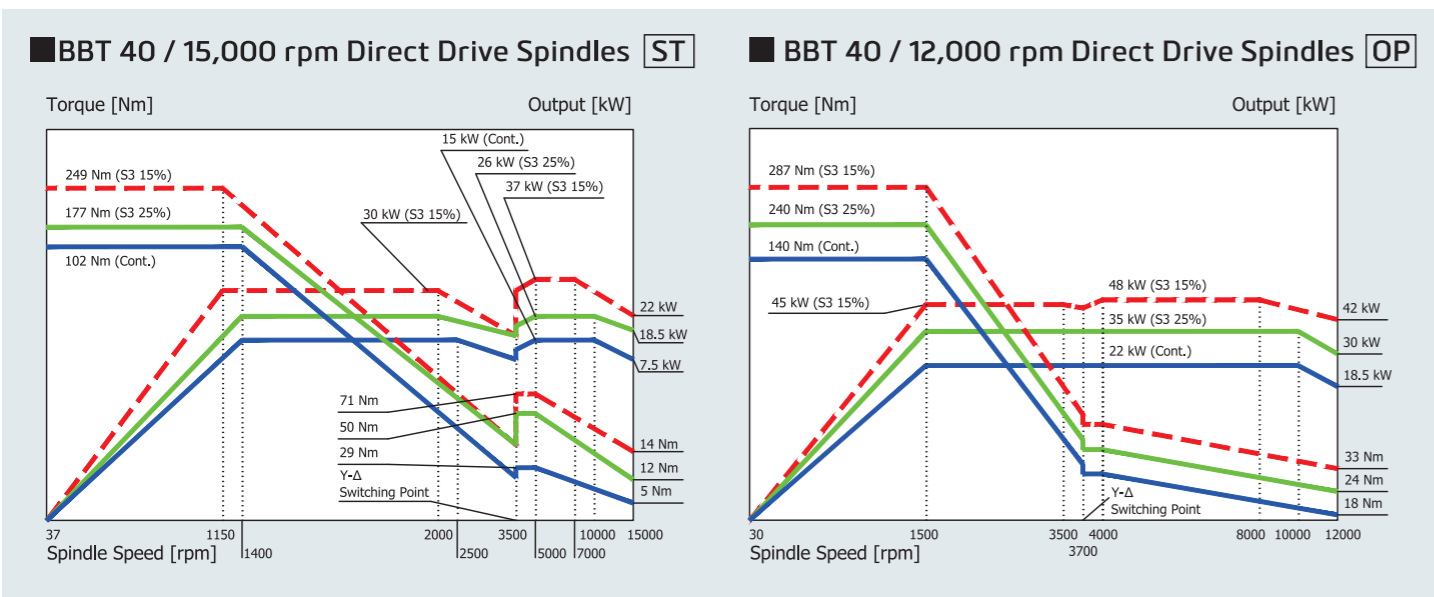

# Automatic Pallet Changer (APC)

# 6 Pallets Pool Expansion Unit

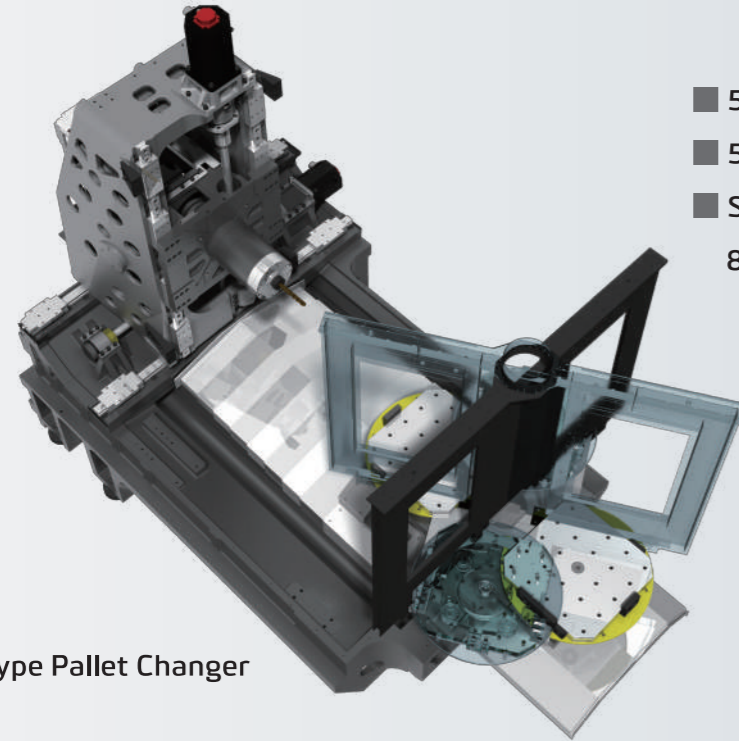

- 5 seconds pallet change rotating time.
- 550 kg [1,210 lb] payload each pallet.
- Swing 785 mm [30.9"] for HS-450 series, 800 mm [31.5"] for HS-540/550 series.

Rotate Type Pallet Changer



6 Pallets Expansion Unit

2 Pallets Machine



6 Pallets with Your Choice of Tool Magazine

- 1°, 0.001° Minimum Table Indexing.
- 33.3 rpm, 66.6 rpm Table Rotating Speed.
- 3,500 Nm [2,580 lb-ft], 6,000 Nm [4,425 lb-ft] B-axis Clamping Force.
- 4,000 kgf [8,810 lbf] Pallet Clamping Force.

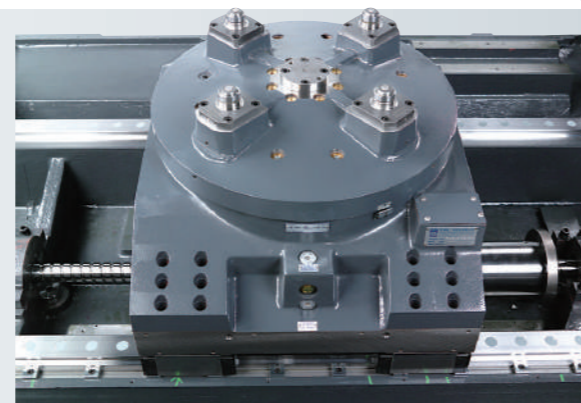

Full 4th Rotary Table

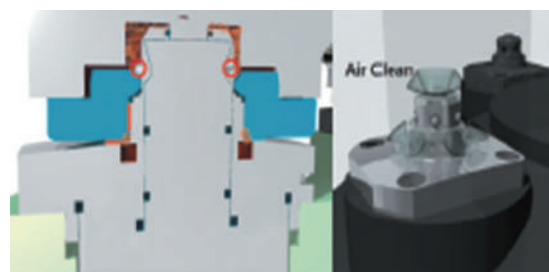

Pallet Clamping System

- 4 tapered cones equipped with air sensors to confirm the pallets are accurately positioned and seated.
- Pallets are mechanically clamped by a ball locking system which generates a powerful 4,000 kgf [8,810 lbf] clamping force.
- High pressure air cleans with sealing detection during pallet changing.

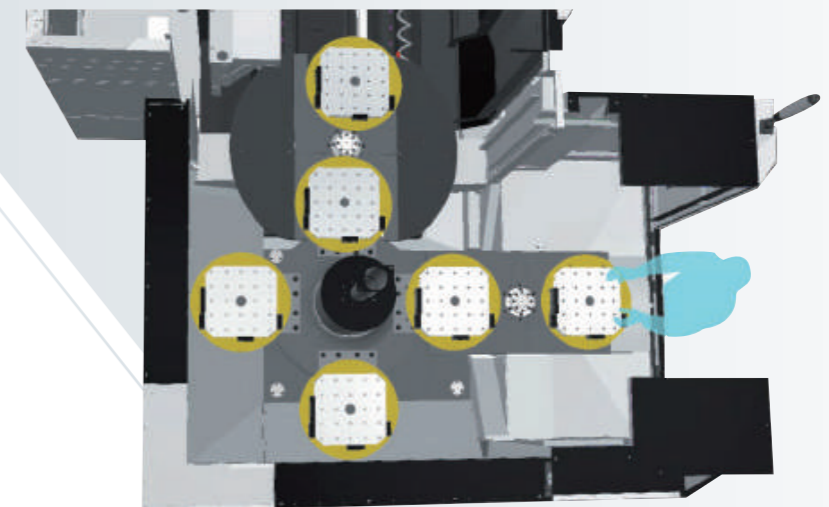

6 Pallets Operation

# Automatic Tool Changer (ATC)

## HS-450i / HS-540i GTS

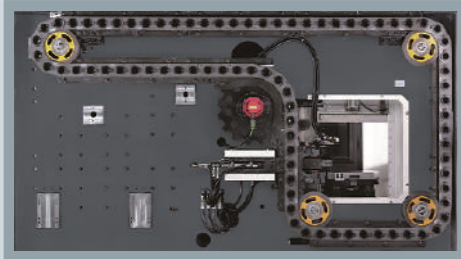

80 Tools **ST**

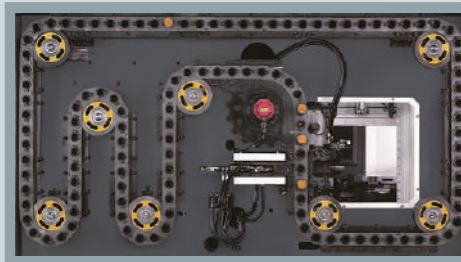

120 Tools **OP**

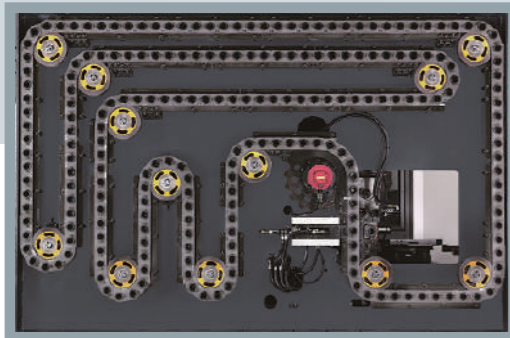

220 Tools **OP**

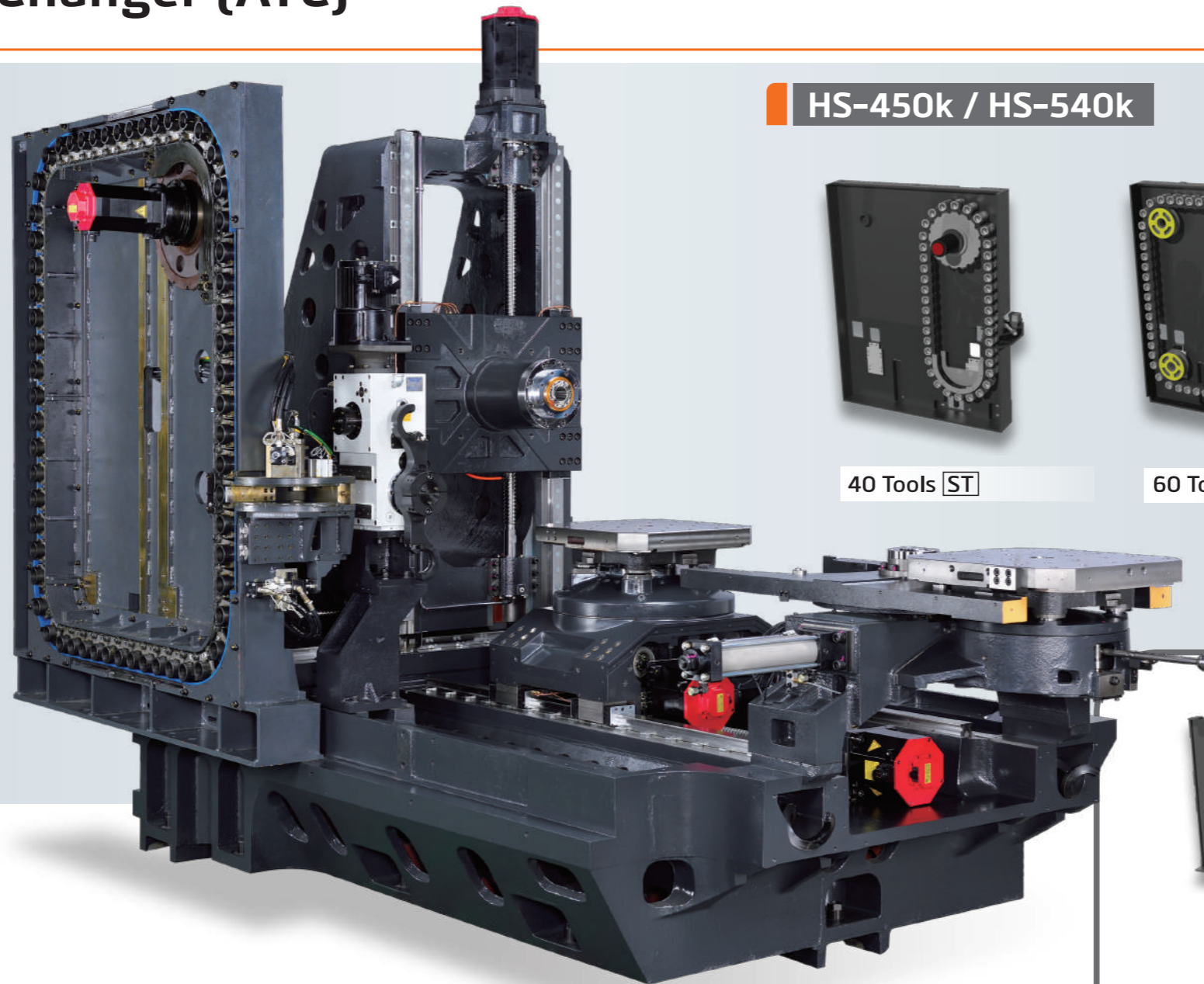

## HS-450k / HS-540k



40 Tools **ST**

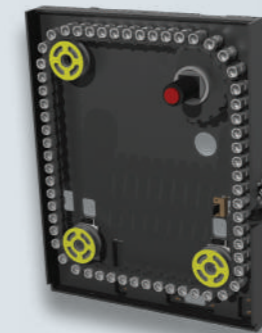

60 Tools **OP**

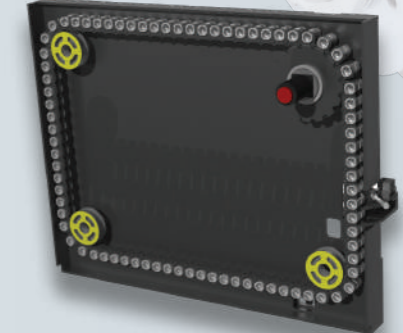

80 Tools **OP**

## HS-550 series

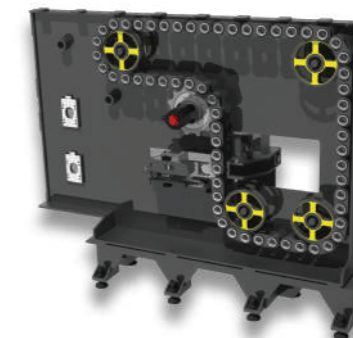

60 Tools **ST**

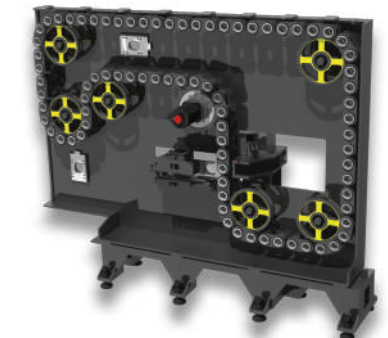

80 Tools **OP**

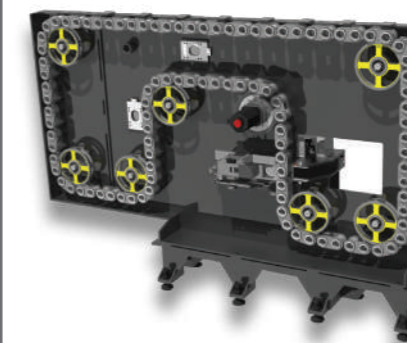

100 Tools **OP**

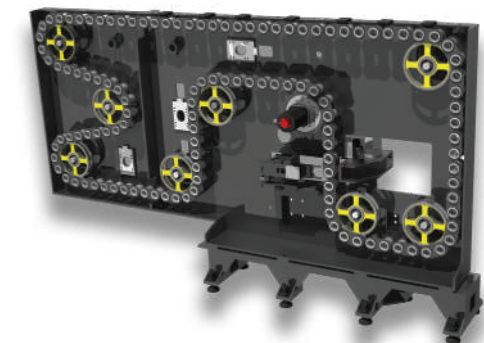

120 Tools **OP**

## Tool Specifications

With adjacent tool(s)

HS-450/540:35mm[1.38"]  
HS-550:45mm[1.77"]

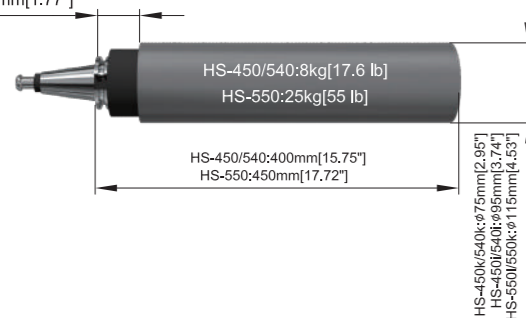

Without adjacent tool(s)

HS-450/540:55mm[2.17"]  
HS-550:60mm[2.36"]

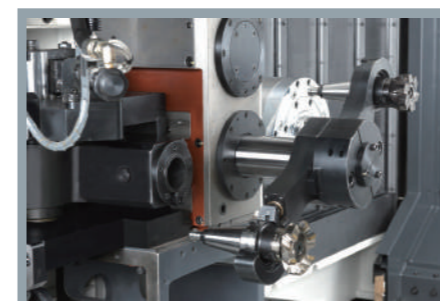
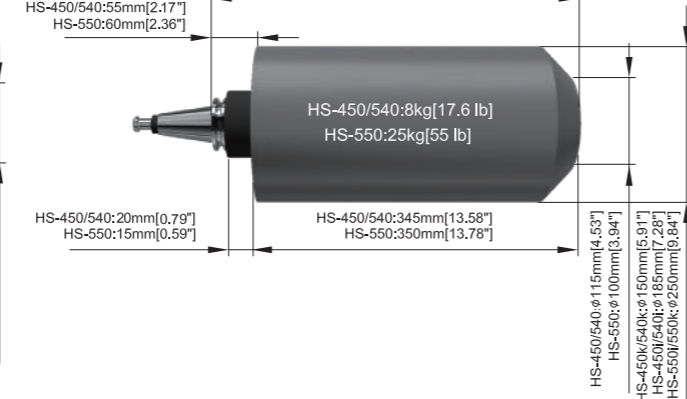

T to T Changing Time  
HS-450 / 540 series: 1 second  
HS-550 series: 2.2 second

# Efficient Chips Evacuation

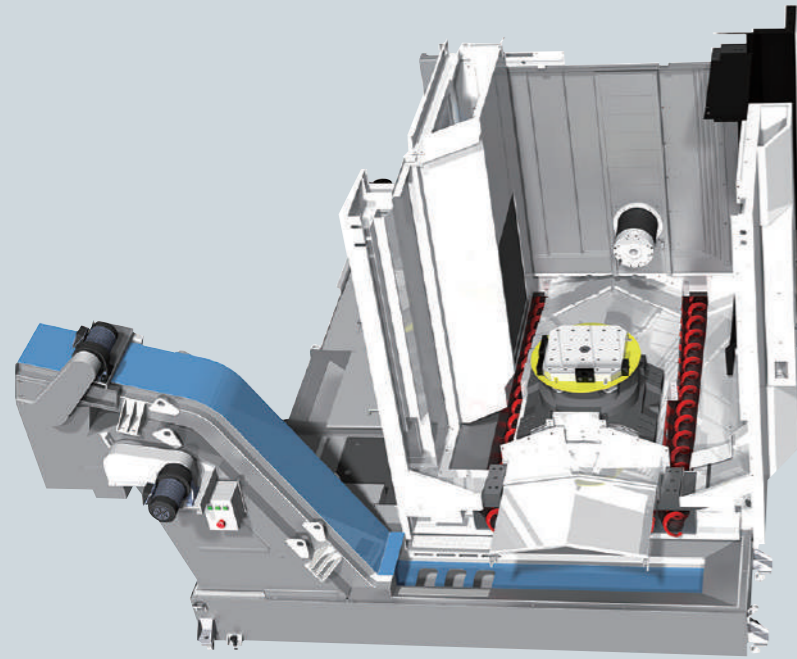

Dual Chip Augers



14 Nozzles Coolant Shower

## Large Capacity Coolant Tank **ST**

HS-450 / 540 series: 750 L  
HS-550 series: 810 L

Floating Ball Type Level  
Detection for Coolant Tank

30 Bar (435 psi) Thru  
Spindle Coolant Pump

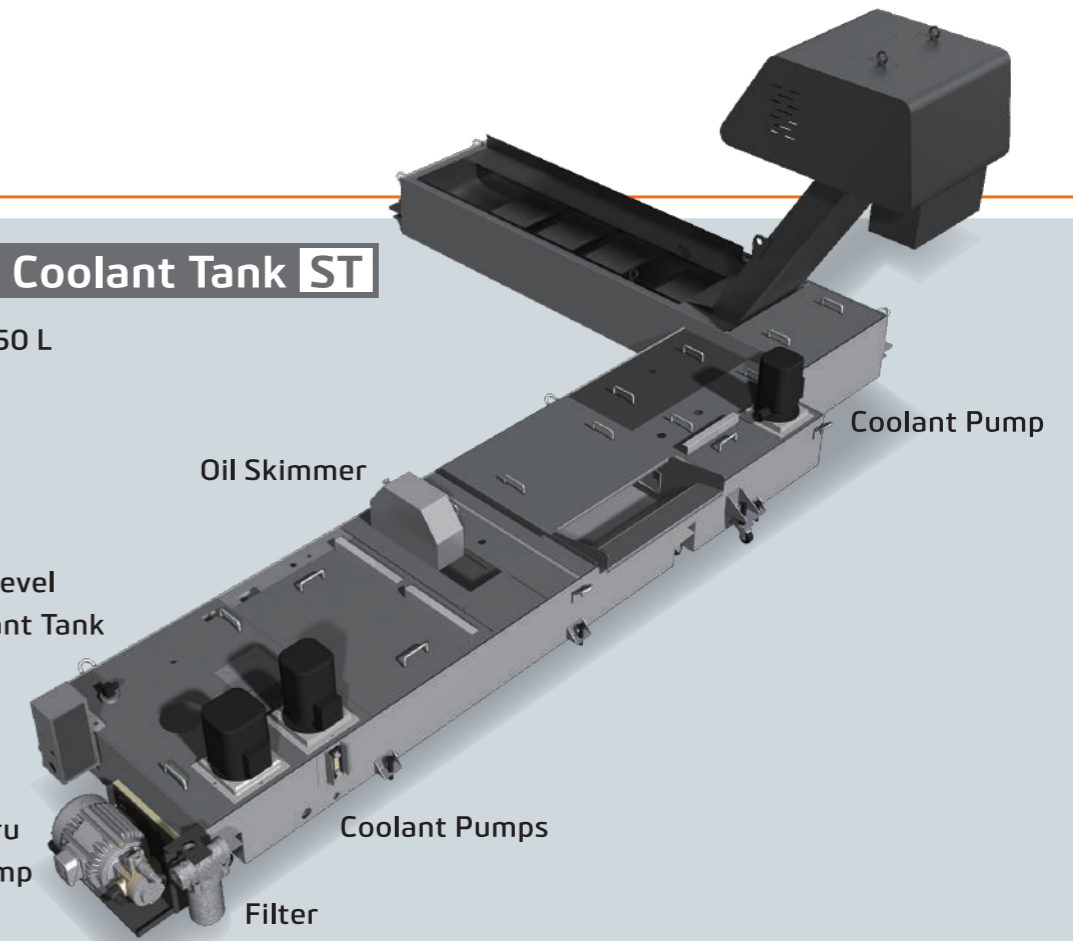

Oil Skimmer

Coolant Pump

Coolant Pumps

Filter

## Compact Chips Evacuation



Photo shows HS-450i 6APC with optional scraper type chip conveyor

## Chip Conveyor **OP**

Type \ Chips	Curly Iron Chips	Metallic Chips	Non-Curly Chips	Foundry Chips	Curly Aluminum Chips	Aluminum Chips	Brass Chips	Non-Metallic Chips
	Steel Belt Type	●	●			●		
Scraper Type			●	●		●	●	
Magnetic Scraper Type			●	●				
Dual Belt Roller Type	●	●	●	●	●	●	●	●



Steel Belt Type



Scraper Type



Magnetic Scraper Type



Dual Belt Roller Type

# Operation and Maintenance



**A** HS-450 series: 760 mm [29.9"]  
HS-540/550 series: 790 mm [31.1"]

**B** HS-450 series: 234 mm [9.2"]  
HS-540/550 series: 242 mm [9.5"]

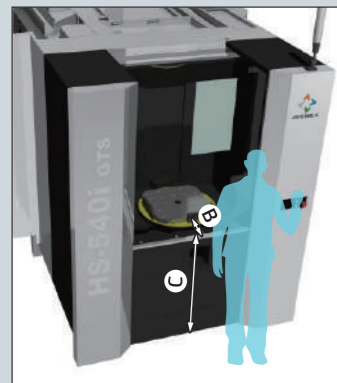

**C** HS-450 series: 1,100 mm [43.3"]  
HS-540/550 series: 1,070 mm [42.1"]

**D** HS-450 series: 535 mm [21.1"]  
HS-540/550 series: 565 mm [22.2"]

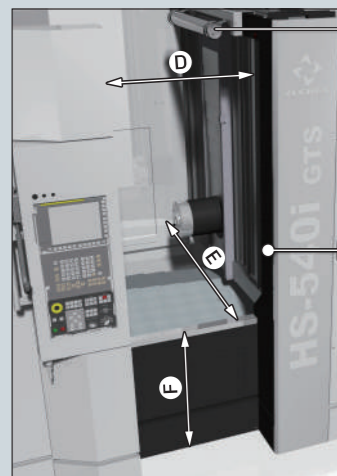

Machining Zone Working Light



Manual Tool Clamp / Unclamp

**E** HS-450 series: 460 mm [18.1"]  
HS-540/550 series: 370 mm [14.6"]

**F** HS-450 series: 815 mm [32.1"]  
HS-540/550 series: 805 mm [31.7"]



24 hrs / 7 days  
Weekly Timer

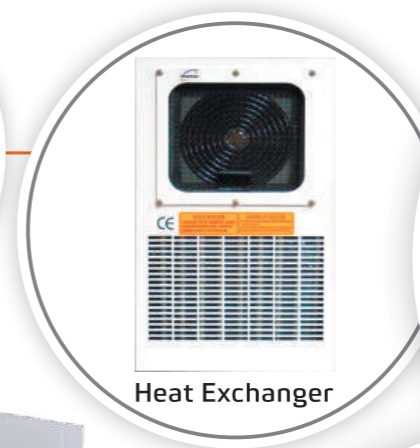

Heat Exchanger

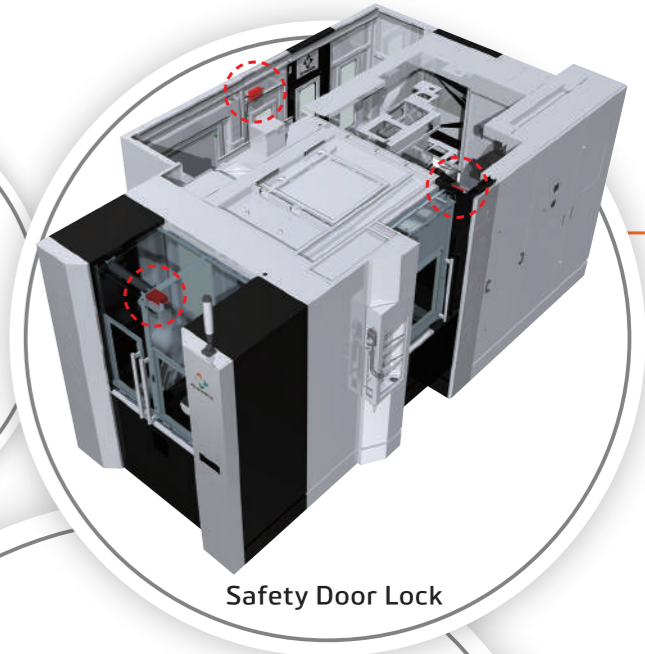

Safety Door Lock



HS-450 series



Swing Type Operator Panel



HS-540/550 series

# Superior Cutting Performance

# High Precision

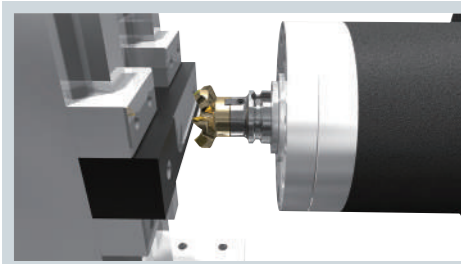

Face Milling Material : Aluminium 6061/7075

HS-450 series	
2,520 cc/min Metal Removal Rate	
Tool	Ø63mm x 6T [Ø2.48" x 6T]
Spindle Speed	12,000 rpm
Feed Rate	20,000 mm/min [787.4 ipm]
Cut Width / Depth	50.4 mm / 2.5 mm [1.98" / 0.10"]
Spindle Load	111%

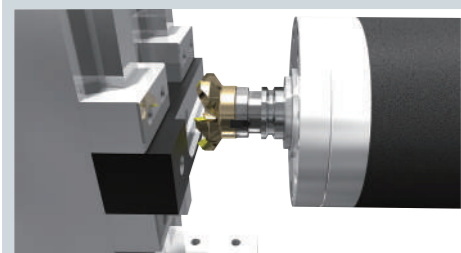

Face Milling Material : Steel S45C

630 cc/min Metal Removal Rate	
Tool	Ø80mm x 6T [Ø3.15" x 6T]
Spindle Speed	1,000 rpm
Feed Rate	1,800 mm/min [70.9 ipm]
Cut Width / Depth	70 mm / 5.0 mm [2.76" / 0.20"]
Spindle Load	115%

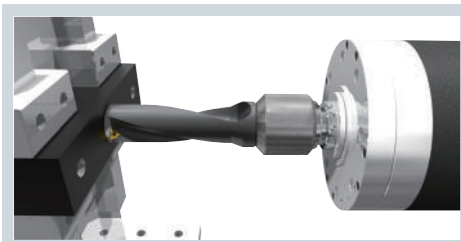

Drilling Material : Steel S45C

451 cc/min Metal Removal Rate	
Tool	Ø50 mm x 2T [Ø1.97" x 2T]
Spindle Speed	1,150 rpm
Feed Rate	230 mm/min [9.1 ipm]
Spindle Load	101%

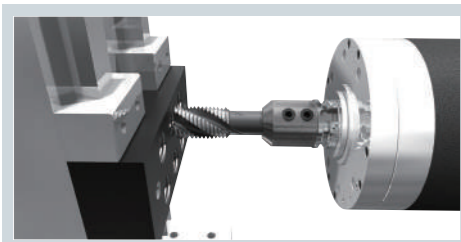

Tapping Material : Steel S45C

M42x4.5P	
Tool	M42 x 4.5P
Spindle Speed	76 rpm
Feed Rate	342 mm/min [13.5 ipm]
Spindle Load	156%

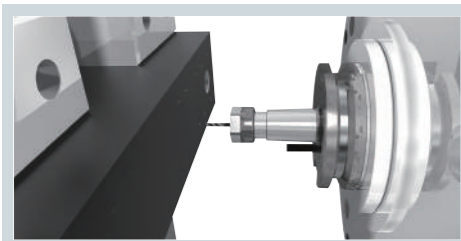

Rigid Tapping Material : Aluminium 6061

O#-80UNF	
Tool	O#-80UNF
Spindle Speed	3,000 rpm
Feed Rate	952.5 mm/min [37.5 ipm]

HS-540 series	
2,600 cc/min Metal Removal Rate	
Tool	Ø63mm x 6T [Ø2.48" x 6T]
Spindle Speed	12,000 rpm
Feed Rate	20,000 mm/min [787.4 ipm]
Cut Width / Depth	52 mm / 2.5 mm [2.05" / 0.10"]
Spindle Load	368%

660 cc/min Metal Removal Rate	
Tool	Ø80mm x 7T [Ø3.15" x 7T]
Spindle Speed	2,000 rpm
Feed Rate	8,000 mm/min [315.0 ipm]
Cut Width / Depth	55 mm / 1.5 mm [2.17" / 0.06"]
Spindle Load	217%

451 cc/min Metal Removal Rate	
Tool	Ø50 mm x 2T [Ø1.97" x 2T]
Spindle Speed	1,150 rpm
Feed Rate	230 mm/min [9.1 ipm]
Spindle Load	110%

M42x4.5P	
Tool	M42 x 4.5P
Spindle Speed	76 rpm
Feed Rate	342 mm/min [13.5 ipm]
Spindle Load	238%

O#-80UNF	
Tool	O#-80UNF
Spindle Speed	3,000 rpm
Feed Rate	952.5 mm/min [37.5 ipm]

HS-550 series	
4,800 cc/min Metal Removal Rate	
Tool	Ø100mm x 7T [Ø3.94" x 7T]
Spindle Speed	10,000 rpm
Feed Rate	12,000 mm/min [472.4 ipm]
Cut Width / Depth	80 mm / 5.0 mm [3.15" / 0.20"]
Spindle Load	168%

777 cc/min Metal Removal Rate	
Tool	Ø125mm x 8T [Ø4.92" x 8T]
Spindle Speed	675 rpm
Feed Rate	3,240 mm/min [127.6 ipm]
Cut Width / Depth	100 mm / 2.4 mm [3.94" / 0.09"]
Spindle Load	175%

512.4 cc/min Metal Removal Rate	
Tool	Ø80 mm x 2T [Ø3.15" x 2T]
Spindle Speed	750 rpm
Feed Rate	188.4 mm/min [7.4 ipm]
Spindle Load	113%

M56x5.5P	
Tool	M56 x 5.5P
Spindle Speed	58 rpm
Feed Rate	319 mm/min [12.6 ipm]
Spindle Load	178%

O#-80UNF	
Tool	O#-80UNF
Spindle Speed	3,000 rpm
Feed Rate	952.5 mm/min [37.5 ipm]

## Positioning & Repeatability

Standard Code	ISO 10791-4	HS-450 / 540 / 550 series
Travel	Full Stroke	Full Stroke
Positioning A	0.025 mm [0.00098"]	0.0050 mm [0.00019"]
Repeatability R	0.015 mm [0.00059"]	0.0028 mm [0.00011"]

## HS-450 / 540 series

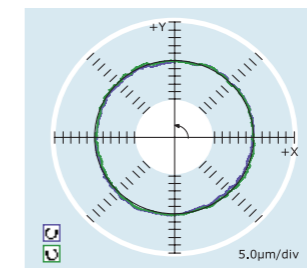

**Circularity: 4.8 µm**

Feed Rate	1,000 mm/min [39.4 ipm]
Radius	150 mm [5.9"]

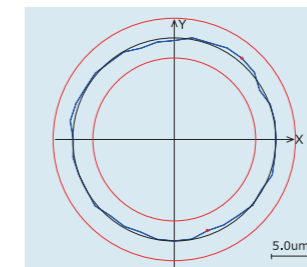

**Roundness: 3.3 µm**

Material	AL 6061 (Ø108 mm) [Ø4.25"]
Tool	Ø20 mm (3T) [Ø0.79"] (3T)
Spindle Speed	4,777 rpm
Feed Rate	1,453 mm/min [57.2 ipm]

## HS-550 series

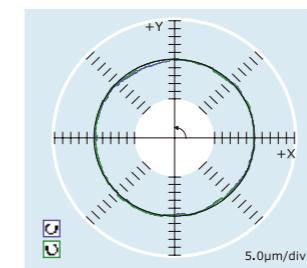

**Circularity: 4.8 µm**

Feed Rate	1,000 mm/min [39.4 ipm]
Radius	150 mm [5.9"]

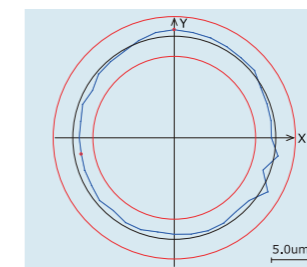

**Roundness: 3.8 µm**

Material	AL 6061 (Ø150 mm) [Ø5.9"]
Tool	Ø20 mm (3T) [Ø0.79"] (3T)
Spindle Speed	4,777 rpm
Feed Rate	1,453 mm/min [57.2 ipm]



# Optional Automation

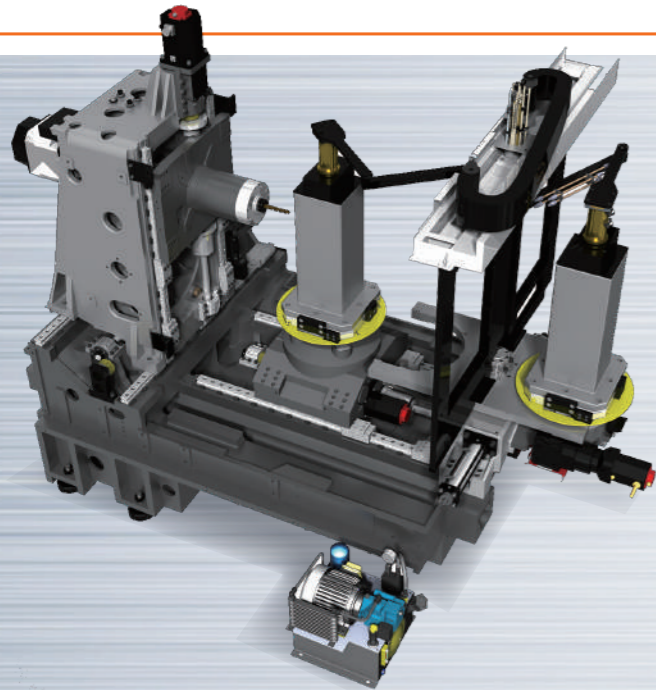

## Hydraulic Overhead Arms for Fixtures

- Pressure source 1,000 psi (7 MPa) / 3,000 psi (20 MPa).
- Hydraulic circuits with pneumatic 4x4 channels / 6x6 channels / other channels.
- Automatic Pallet Indexing at Loading Zone 90 / 180 / 270 / 360 degrees.

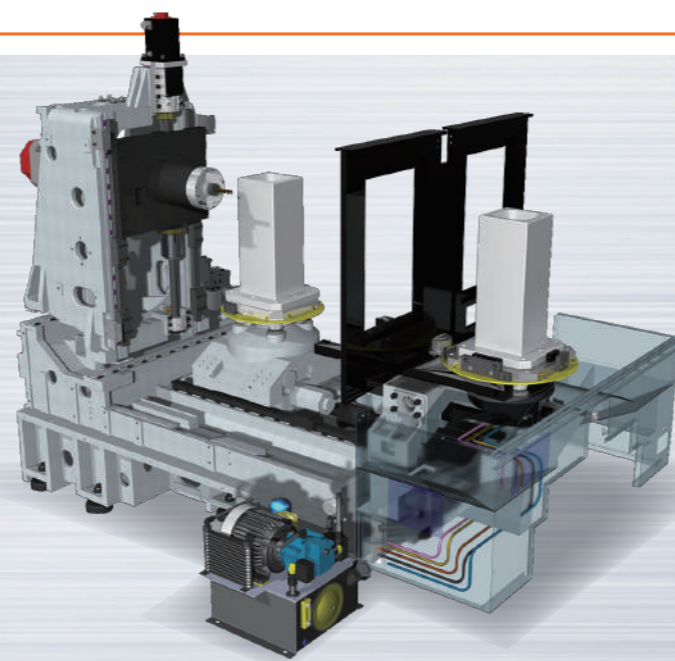

## Hydraulic Thru Pallets for Fixtures

- Pressure source 1,000 psi (7 MPa) / 3,000 psi (20 MPa).
- Hydraulic circuits with pneumatic 2x2 channels / 4x4 channels.

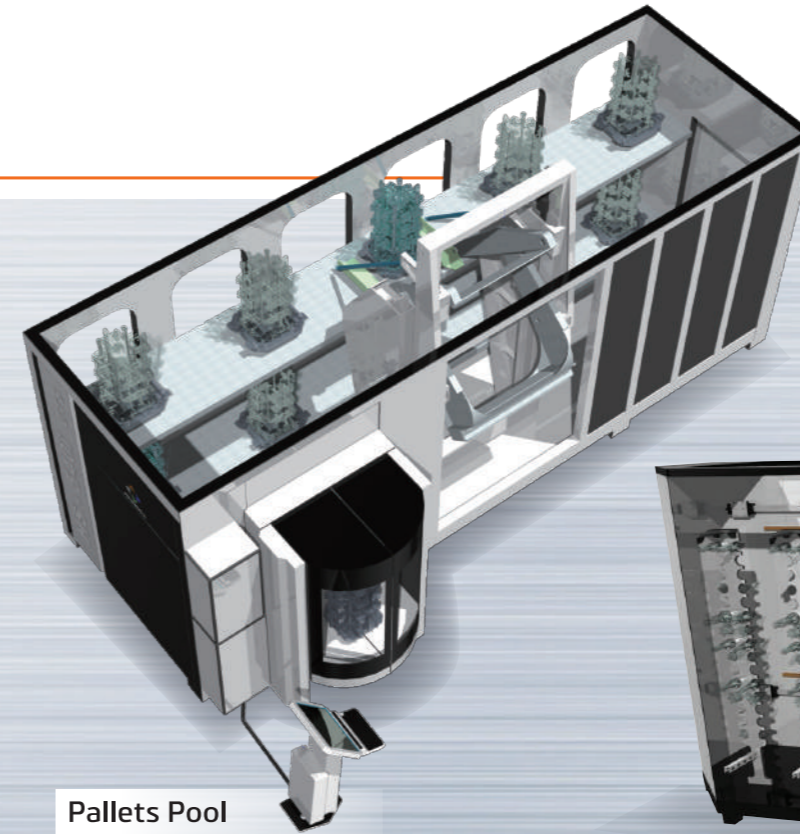

Pallets Pool

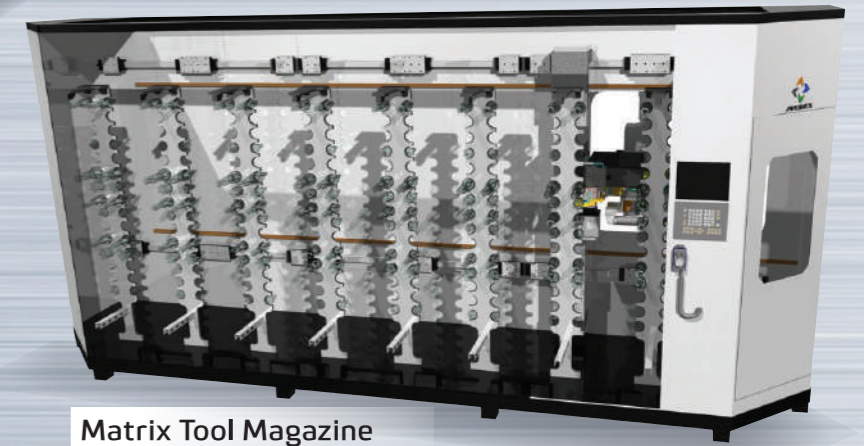

Matrix Tool Magazine



## Pneumatic Workpiece Clamping Detection

- Pneumatic 87 psi (0.6 MPa) for workpiece clamping detection.

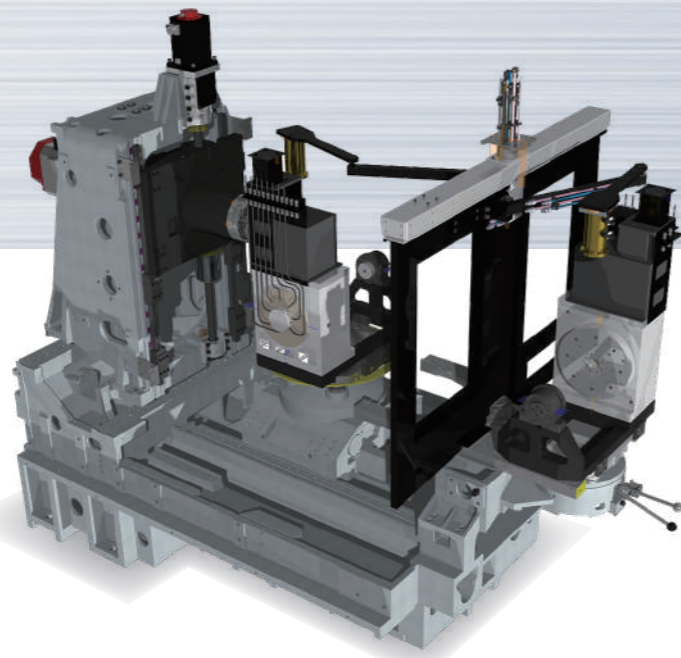

## 4+1 Axis Machines

- Pressure source 1,000 psi (7 MPa) / 3,000 psi (20 MPa).
- Hydraulic circuits with pneumatic 4x4 channels / 6x6 channels / other channels.
- Single / Twin C axis.
- Index 1 degree / 0.001 degree for C axis.
- Dia. of C axis  
 $\varnothing 220\text{mm} / \varnothing 250\text{mm} / \varnothing 280\text{mm} / \varnothing 320\text{mm}$   
 $[\varnothing 8.66" / \varnothing 9.84" / \varnothing 11.02" / \varnothing 12.60"]$
- Bearing Tailstock.

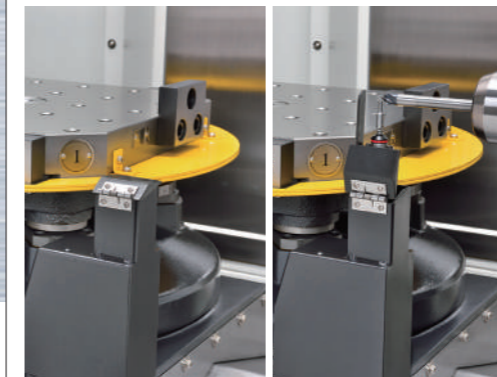

Retractable Tool Measurement

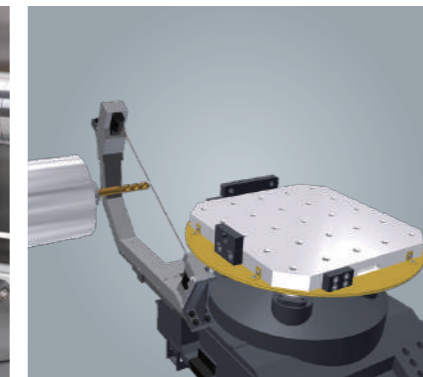

Laser Tool Measurement

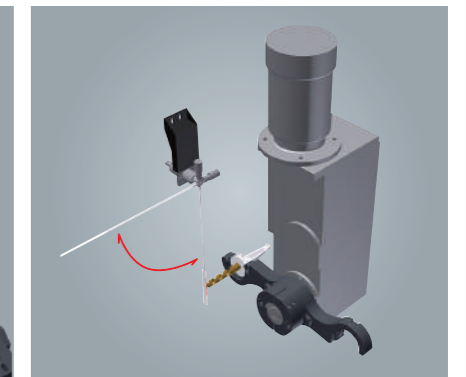

Tool Breakage Detection



Workpieces Measurement

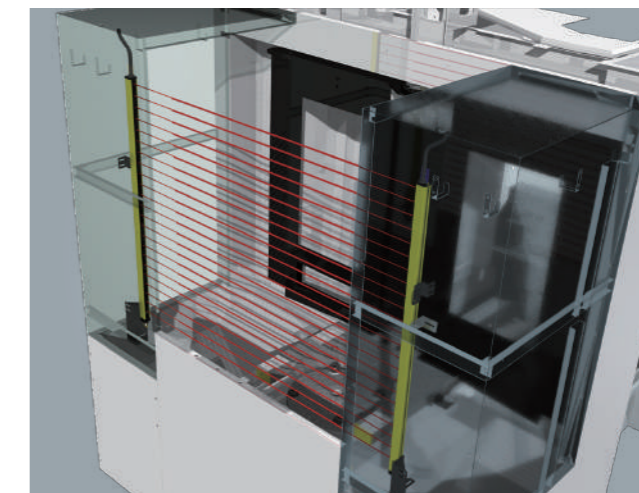

Safety Light Curtain

# Optional Accessories



Rear Side Chips Disposer  
(HS-540/550 series machines)



70 Bar Coolant Thru Spindle



Window Spinning Wiper

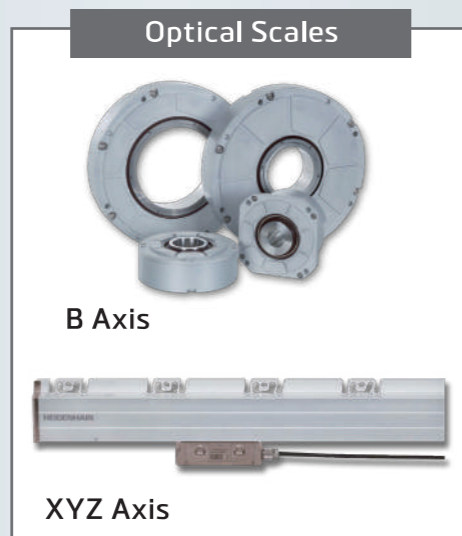

Optical Scales

B Axis

XYZ Axis



Coolant Mist Collector

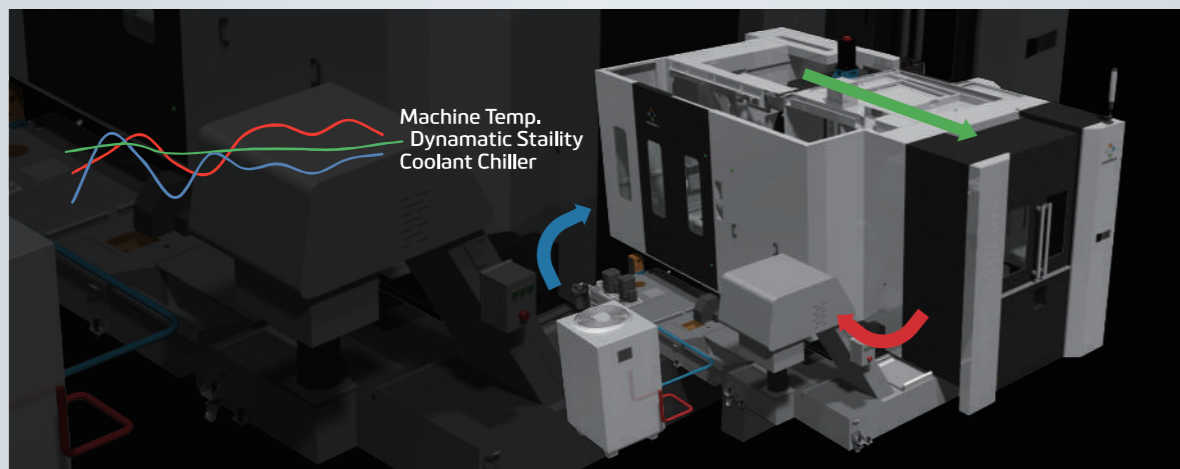

Inverter Chiller for Coolant Tank

# CNC Specifications

## AVEREX-FANUC Mpro I **ST** / AVEREX-FANUC Mpro III **OP**



PC CF card slot allows part programs storage/retrieval or DNC machining

USB slot allows part programs storage/retrieval

### Special Value Package

- 10.4" Color LCD
- 1280 meter Part Program Memory
- HRV-III<sup>+</sup> Servo Drives
- JERK Control
- AICC II Nano Control with 200 Blocks Look Ahead
- Ethernet and CF/USB Device
- Manual Guide Oi
- Multi-language Display
- High Speed Skip
- Rigid Tapping
- Canned Cycle
- Helical Interpolation
- Circular Interpolation
- Custom Macro B
- Custom Macros-Common Variables #600-#999
- Tool Life Management
- 1000 Registerable Programs
- 48 Pairs Workpiece Coordinate Offsets
- Tool Offset G45 to G48
- 400 Pairs Tool Offsets
- Tool Offset Memory C
- Programmable Data Input G10
- Coordinate System Rotation
- Polar Coordinate Command
- Scaling
- Program Restart
- Manual Handle Interruption
- Programmable Mirror Image
- Programmable Spindle Tool Load Monitoring
- Programmable ATC Speed
- Programmable Tool Magazine Speed

### Optional

- Stored stroke check 2
- Single direction positioning
- Cylindrical interpolation
- F1-digit feed
- Addition of optional block skip
- Optional chamfering/corner R
- Tool offset memory B
- Playback function
- 6 Pallet management table
- Data server with high speed (Ethernet and 1GB memory)
- AI contour control II, High-Speed processing
- 400 buffer blocks
- Nano smoothing
- Interruption type custom macro

### FEATURES

Number of controllable axes	4 axes (X/Y/Z/B)
Number of simultaneously controllable axes	4 axes (X/Y/Z/B)
Least input increment	0.001 mm / 1°
Least setting increment	0.001 mm / 1°
Bell shaped acceleration/deceleration before look-ahead interpolation	
HRV-III <sup>+</sup> high performance axis drives	
Inch / metric conversion	G20 / G21
AI contour control II	200 buffer blocks
Position Switch	

### FEED FUNCTION

Cutting feed override	0 ~ 200% (by 10%)
Dwell	G04
Zero point return	G27 to G30
Handle feed	0.001 / 0.01 / 0.1 mm, 1°
Manual Jog feed	0 to 2,000 mm/min. (20 steps)
Dry run	
Rapid traverse rate override	0 / 8 / 15 / 25 / 50 / 100 (%)

### TOOL FUNCTION

Tool function	4-digit T code
Cutter compensation C	G40 to G42
Too length compensation	G43 / G44 / G49
Tool offset capacity	400 pcs
Tool offset memory C	
Tool life management	
Tool radius / tool nose radius compensation	

### EDITING FUNCTION

Tape code	EIA RS244 / ISO 840 Automatic recognition
Input / output interface	RS232C, RJ45, CF card, USB
Part program storage length	512 Kbyte
Number of registered programs	1,000 pcs
Search function	Program number search Sequence number search Address search

Extended part program editing  
Background editing

### SPINDLE FUNCTION

Spindle speed function	5-digit S code
Spindle speed override	50-150% (by 10%)

### PROGRAM INPUT

Absolute / incremental programming	G90 / G91
Canned cycles	G73 / G74 / G76 / G80 to G89
Decimal point programming	Input by using decimal point
Circular interpolation by R programming	
Subprogram call	10 folds levels nested
Local / machine coordinate system	G52 / G53
Workpiece coordinate system	G54 ~ G59
Addition of work coordinate system	300 sets
Max. programmable dimension	±9-digit
M function	3-digit M code
Custom macro B	

### OTHERS

MDI / LCD Unit	10.4" Color LCD, Keyboard, and Soft Keys
Programmable Data Input	G10
Rigid tapping	Synchronized tapping
Stored stroke check 1	
Help function	Explanation of alarm messages
Run hour and parts count display	
Operating monitor display	
Stored pitch error compensation	
English language display	
Multi-language display	
Thread cutting	
Synchronous cutting	
Helical interpolation	
Ethernet function	



# Floor Space

## 2 APC Machines

### HS-550 series

Item	Position	HS-450	HS-540	HS-550
A	Dual Belt Roller Type	3554 [139.92"]		
	Steel Belt Type	3133 [123.35"]		
	Scraper (Magnetic) Type	2867 [112.87"]		
B	Machine to chip conveyor	1514 [59.61"]		
C	Chips Collection	953 [37.52"]		
D	Machine dimension: L	4730 [186.22"]	4931 [194.13"]	
E	Machine dimension: H	2600 [102.36"]	2706 [106.54"]	2942 [115.83"]

Unit: mm [inch"]

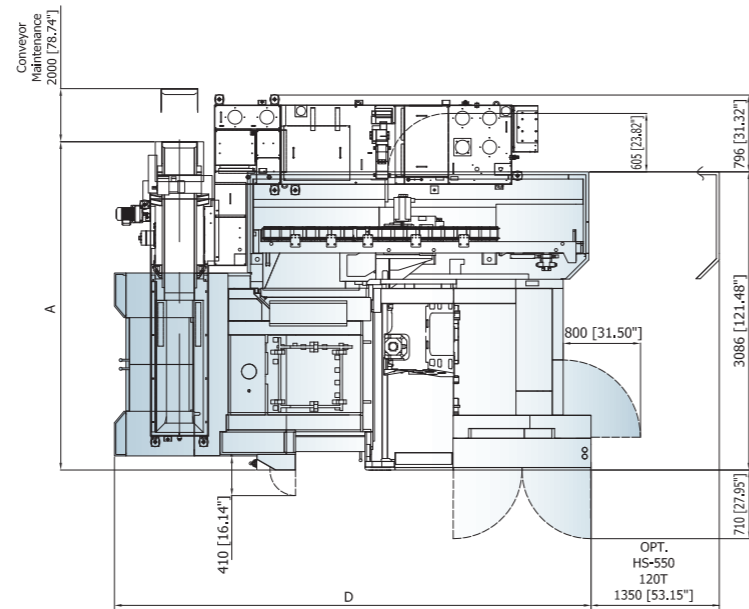

## 6 APC Machines

### HS-550 series

Item	Position	HS-450	HS-540	HS-550
A	Dual Belt Roller Type	4690 [184.65"]		
	Steel Belt Type	4269 [168.07"]		
	Scraper (Magnetic) Type	4003 [157.60"]		
B	Machine to chip conveyor	1514 [59.61"]		
C	Chips Collection	953 [37.52"]		
D	Machine dimension: L	5788 [227.87"]	5980 [235.43"]	
E	Machine dimension: H	2600 [102.36"]	2706 [106.54"]	2942 [115.83"]

Unit: mm [inch"]

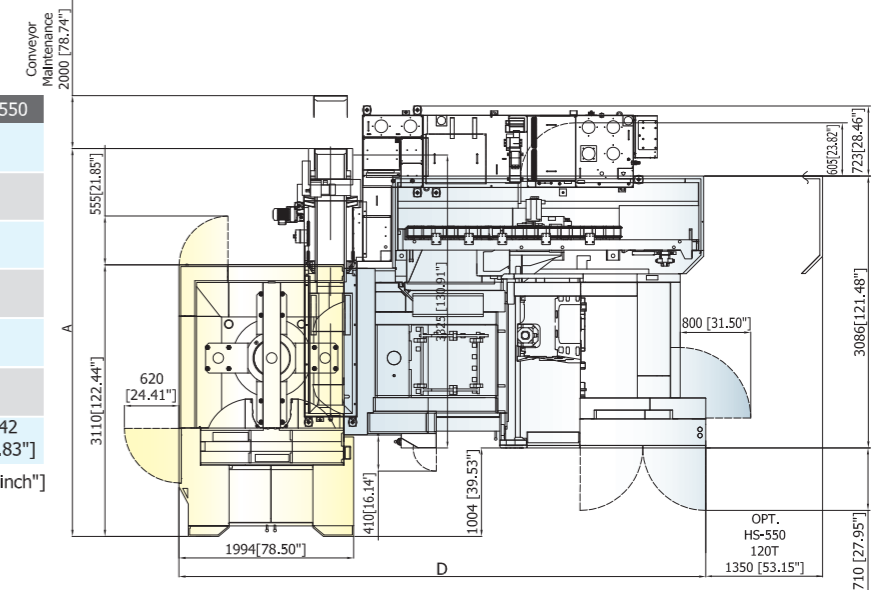

### HS-450/540 series

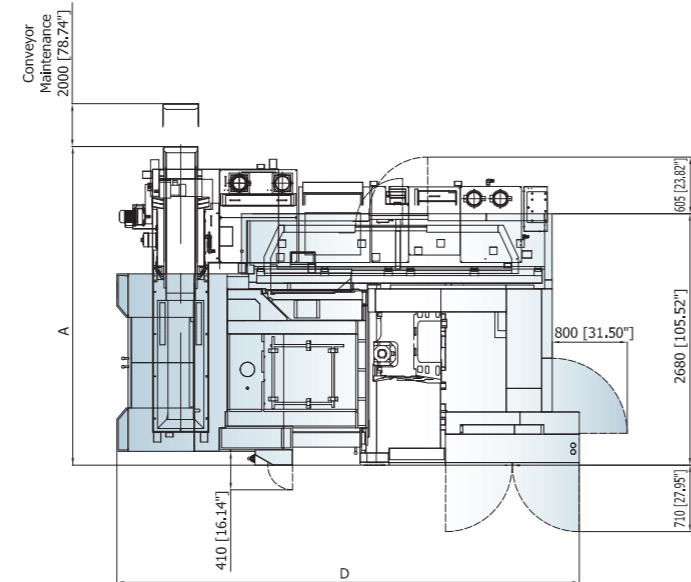
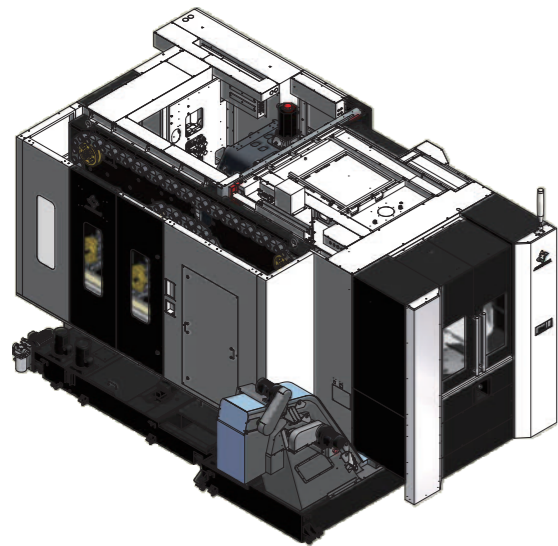

### HS-450/540 series

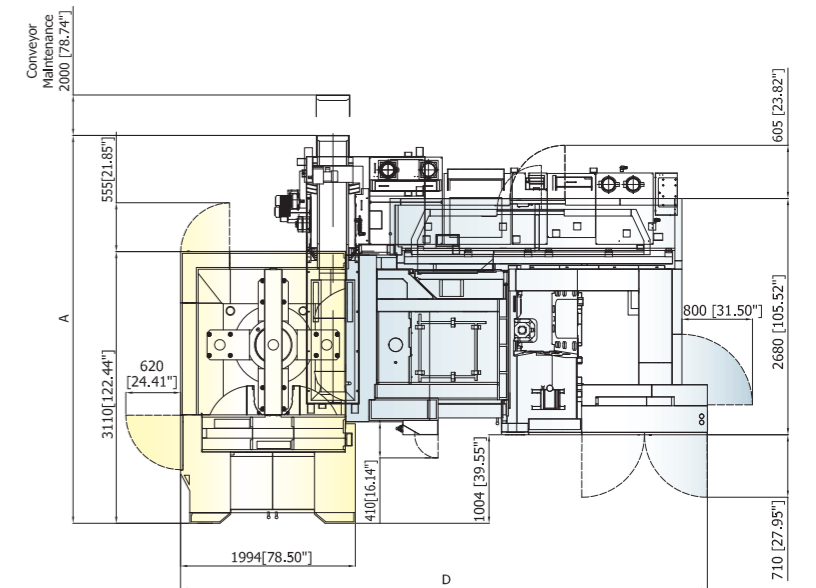
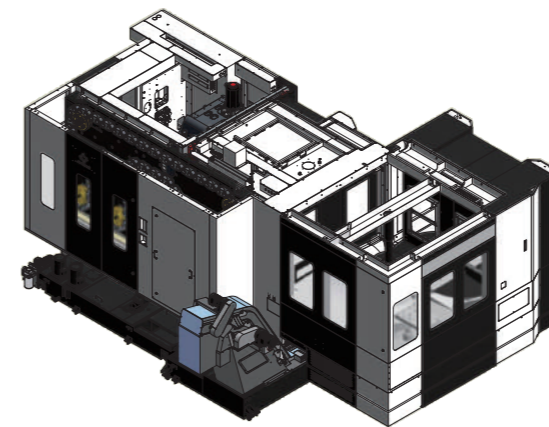

### HS-450/540/550 series

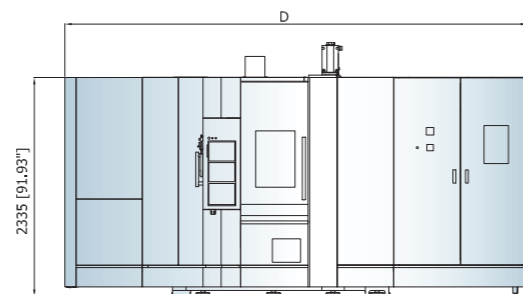
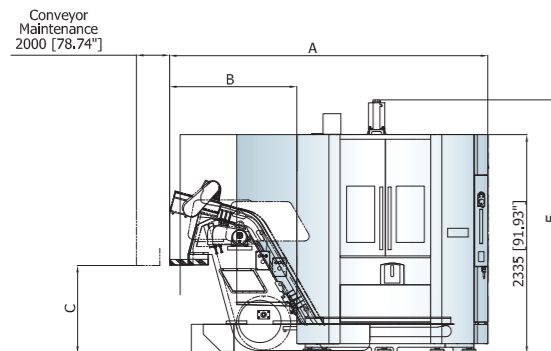

Unit: mm [inch"]

### HS-450/540/550 series

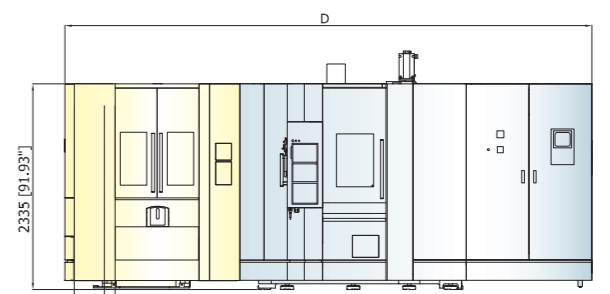
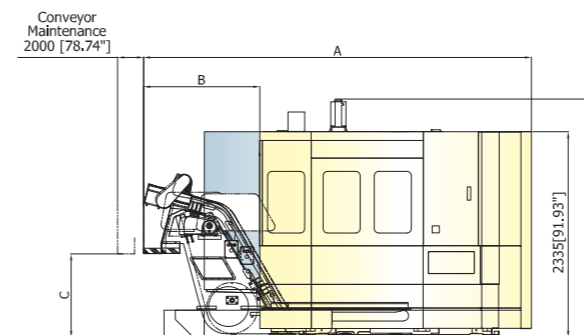

Unit: mm [inch"]

# HS-450 Series Specifications

	HS-450i	HS-450k
<b>TRAVEL</b>		
X/Y/Z-axis	640 / 610 / 680mm [25.2" / 24.0" / 26.8"]	
Spindle center to pallet surface	50 - 660mm [2.0"-26.0"]	
Spindle nose to pallet center	100 - 780mm [3.9"-30.7"]	
Pallet top height (from the floor)	1,100mm [43.3"]	
<b>TABLE</b>		
Table Size (OP)	400 x 400mm (500 x 500mm) [15.7" x 15.7" (19.7" x 19.7")]	
Workpiece max. size	Ø 785 x 1,000mm [Ø30.9" x 39.4"]	
Max. payload	550kg [1,210 lb]	
Configuration (OP)	M16x25L, P=80mm (P=100mm) [M16 x25L, P=3.1" (P=3.9")]	
Min. indexing degree (OP)	0.001°	1° (0.001°)
Indexing speed (OP)	1.1 sec/90°	2.0sec/90° (1.1 sec/90°)
B-axis clamping torque	3,500Nm [2,580 lb-ft]	
Pallet clamping system	Mechanical Lock	
Pallet clamping force	4,000kgf [8,810 lbf]	
<b>SPINDLE</b>		
Spindle speed (OP)	37 ~ 15,000rpm (12,000rpm, 20,000 rpm)	
Spindle rated torque	102Nm (Cont.) [75 lb-ft] 249Nm (S3 15%) [184 lb-ft]	
Spindle acceleration/deceleration	3.2 sec (0-15k rpm) / 3.3 sec (15k-0rpm)	
Spindle taper (OP)	BBT 40 (CAT 40, DIN69871-40, HSK 63A)	
Through spindle coolant (OP)	3.0 MPa (7.0 MPa) [435psi (1,000 psi)]	
<b>FEED</b>		
Rapid feed (X/Y/Z)	60,000mm/min [2,362ipm]	
Cutting feed (X/Y/Z)	1 ~ 40,000mm/min [1 ~ 1575ipm]	
Table rotating speed	33.3rpm	
Guide ways(X/Y/Z)	Roller ways	
Acceleration(X/Y/Z)	1G	
Ballscrews size	Ø40mm [1.5748"]	
<b>ATC</b>		
Type of pull-stud (OP)	JIS 40P (DIN69872-40, DIN69872-40)	
Number of tools (OP)	80T (120T, 220T)	40T (60T, 80T)
Max. tool diameter (Adjacent pots full/empty)	Ø95/185mm [Ø3.74"/7.28"]	Ø75/150mm [Ø2.95"/5.91"]
Max. tool length	400mm [15.75"]	
Max. tool weight	8kg [17.6 lb]	
Tool selection system	Fixed / Random	Random
Tool to tool	1.0sec (2.1sec, heavy tool)	
Chip to chip	3.4sec (4.4sec, heavy tool)	

	HS-450i	HS-450k
<b>APC</b>		
Number of pallets (OP)	2 (6)	
Pallet change system	Rotation	
APC exchange rotating time	5 sec	
<b>MOTORS</b>		
Spindle motor (MAX/cont.)	37/15 kW [50.3/20.4 hp] (12k:48/22 kW [65.3/29.9 hp]) (20k:22/11 kW [29.9/15.0 hp])	
Feed axes motors (X/Y/Z/B)	4.5/5.5/4.5/2.7 kW [6.0/7.3/6.0/3.6 hp]	
Lubrication pump motor	18W/60Hz [0.024 hp/60Hz]	
Spindle coolant pump	1.62 kW/60Hz [2.2hp/60Hz]	
Through spindle coolant pump	2.24 kW/60Hz [3.0hp/60Hz]	
Overhead shower flush coolant pump	1.62 kW/60Hz [2.2hp/60Hz]	
Hydraulic pump	2.23 kW/60Hz [3.0 hp/60Hz]	
Spindle oil chiller	1.95 kW/60Hz [2.6 hp/60Hz]	
<b>SUPPLY</b>		
Electric voltage	200~230 V	
Electric power supply	50 kVA	
Air pressure	0.6 MPa [87 psi]	
Air volume	500 L/min [132 gal/min]	
<b>TANK</b>		
Hydraulic unit tank	60 L [15.9 gal]	
Lubrication unit tank	1.8 L [0.47 gal]	
Coolant tank	750 L [198 gal]	
<b>SIZE</b>		
Machine dimension (LxWxH)	4,730 x 2,660 x 2,600 mm [186.2" x 104.7" x 102.4"]	4,730 x 2,540 x 2,600 mm [186.2" x 100.0" x 102.4"]
Required floor space (LxWxH) (Includes chip conveyor)	5,375 x 4,264 x 2,600 mm [211.6" x 167.9" x 102.4"]	5,375 x 4,010 x 2,600 mm [211.6" x 157.9" x 102.4"]
■ Dual Belt Roller Type		
■ Steel Belt Type		
■ Scraper (Magnetic) Type	5,375 x 3,975 x 2,600 mm [211.6" x 156.5" x 102.4"]	
Machine weight	11,645 kg [25,672 lb]	11,450 kg [25,243 lb]

\*Specifications subject to change without notice.

# HS-540 550 Series Specifications

	HS-540i GTS	HS-540k	HS-550i GTS	HS-550k
<b>TRAVEL</b>				
X/Y/Z-axis	800 / 800 / 800 mm [31.5" / 31.5" / 31.5"]			
Spindle center to pallet surface	40 - 840mm [1.6"-33.1"]			
Spindle nose to pallet center	100 - 900mm [3.9"-35.4"]			
Pallet top height (from the floor)	1,070mm [42.1"]			
<b>TABLE</b>				
Table Size (OP)	500 x 500 mm (400 x 400 mm) [19.7" x 19.7" (15.7" x 15.7")]			
Workpiece max. size	Ø 800 x 1,000 mm [Ø31.5" x 39.4"]			
Max. payload	550kg [1,210 lb]			
Configuration (OP)	M16x25L, P=100mm (P=80mm) [M16 x25L, P=3.9" (P=3.1")]			
Min. indexing degree (OP)	0.001°	1° [0.001°]	0.001°	1° [0.001°]
B-axis clamping torque	6,000 Nm [4,425 lb-ft]	3,500 Nm [2,580 lb-ft]	6,000 Nm [4,425 lb-ft]	3,500 Nm [2,580 lb-ft]
Indexing speed (OP)	1.0 sec/90°	2.0 sec/90° [1.1 sec/90°]	1.0 sec/90°	2.0 sec/90° [1.1 sec/90°]
Pallet clamping system	Mechanical Lock			
Pallet clamping force	4,000 kgf [8,810 lbf]			
<b>SPINDLE</b>				
Spindle speed (OP)	37 ~ 15,000 rpm (12,000 rpm, 20,000 rpm)		25 ~ 10,000 rpm	
Spindle rated torque	102 Nm (Cont.) [75 lb-ft]		252 Nm (Cont.) [186 lb-ft]	
	249 Nm (S3 15%) [184 lb-ft]		568 Nm (S3 15%) [419 lb-ft]	
Spindle acceleration/deceleration	3.2 sec (0-15k rpm) / 3.3 sec (15k-0 rpm)		3.6 sec (0-10k rpm) / 3.7 sec (10k-0 rpm)	
Spindle taper (OP)	BBT 40 (CAT 40, DIN69871-40, HSK 63A)		BBT 50 (CAT 50, DIN69871-50, HSK 100A)	
Through spindle coolant (OP)	3.0 MPa (7.0 MPa) [435 psi (1,000 psi)]			
<b>FEED</b>				
Cutting feed (X/Y/Z)	1 ~ 40,000 mm/min [1 ~ 1575 ipm]			
Rapid feed (X/Y/Z)	74,000 mm/min [2,913 ipm]	60,000 mm/min [2,362 ipm]	74,000 mm/min [2,913 ipm]	60,000 mm/min [2,362 ipm]
Table rotating speed	66.6 rpm	33.3 rpm	66.6 rpm	33.3 rpm
Guide ways (X/Y/Z)	Roller ways			
Acceleration (X/Y/Z)	1G			
Ballscrews size	Ø40 mm [1.5748"]			
<b>ATC</b>				
Type of pull-stud (OP)	JIS 40P (DIN69872-40, DIN69872-40)		JIS 50P (DIN69872-50, DIN69872-50)	
Number of tools (OP)	80T (120T, 220T)	40T (60T, 80T)	60T (80T, 100T, 120T)	
Max. tool diameter (Adjacent pots full/empty)	Ø95/185 mm [Ø3.74"/7.28"]	Ø75/150 mm [Ø2.95"/5.91"]	Ø115/250 mm [Ø4.53"/9.84"]	
Max. tool length	400 mm [15.75"]		450 mm [17.72"]	
Max. tool weight	8 kg [17.6 lb]		25 kg [55.0 lb]	
Tool selection system	Fixed / Random	Random	Fixed / Random	
Tool to tool	1.0 sec (2.1 sec, heavy tool)		2.2 sec (3.1 sec, heavy tool)	
Chip to chip	3.4 sec (4.4 sec, heavy tool)		5.3 sec (5.9 sec, heavy tool)	

	HS-540i GTS	HS-540k	HS-550i GTS	HS-550k
<b>APC</b>				
Number of pallets (OP)	2 (6)			
Pallet change system	Rotation			
APC exchange rotating time	5 sec			
<b>MOTORS</b>				
Spindle motor (MAX/cont.)	37/15 kW [50.3/20.4 hp] (12k:48/22 kW [65.3/29.9 hp]) (20k:22/11 kW [29.9/15.0 hp])		30/26 kW [40.7/35.4 hp]	
Feed axes motors (X/Y/Z/B)	5.5/5.5/4.5/4.5 kW [7.3/7.3/6.0/6.0 hp]	5.5/5.5/4.5/2.7 kW [7.3/7.3/6.0/3.6 hp]	5.5/5.5/4.5/4.5 kW [7.3/7.3/6.0/6.0 hp]	5.5/5.5/4.5/2.7 kW [7.3/7.3/6.0/3.6 hp]
Lubrication pump motor	18W/60Hz [0.024 hp/60Hz]			
Spindle coolant pump	1.62 kW/60Hz [2.2hp/60Hz]			
Through spindle coolant pump	2.24 kW/60Hz [3.0hp/60Hz]			
Overhead shower flush coolant pump	1.62 kW/60Hz [2.2hp/60Hz]			
Hydraulic pump	2.23 kW/60Hz [3.0 hp/60Hz]			
Spindle oil chiller	1.95 kW/60Hz [2.6 hp/60Hz]		3.59 kW/60Hz [4.8 hp/60Hz]	
<b>SUPPLY</b>				
Electric voltage	200~230 V			
Electric power supply	60 kVA		70 kVA	
Air pressure	0.6 MPa [87 psi]			
Air volume	500 L/min [132 gal/min]			
<b>TANK</b>				
Hydraulic unit tank	60 L [15.9 gal]			
Lubrication unit tank	1.8 L [0.47 gal]			
Coolant tank	750 L [198 gal]		810 L [214 gal]	
<b>SIZE</b>				
Machine dimension (LxWxH)	4,931 x 2,680 x 2,706 mm [194.1" x 105.5" x 106.5"]	4,931 x 2,628 x 2,706 mm [194.1" x 103.5" x 106.5"]	4,931 x 3,086 x 2,942 mm [194.1" x 121.5" x 115.8"]	
Required floor space (LxWxH) (Includes chip conveyor) ■ Dual Belt Roller Type	5,619 x 4,264 x 2,706 mm [221.2" x 167.9" x 106.5"]		5,619 x 4,592 x 2,942 mm [221.2" x 180.8" x 115.8"]	
	■ Steel Belt Type			
	5,619 x 3,995 x 2,706 mm [221.2" x 157.3" x 106.5"]			
■ Scraper (Magnetic) Type				
Machine weight	13,190 kg [29,079 lb]	12,520 kg [27,602 lb]	11,700 kg [25,794 lb] (Not Include Tool Magazine) 15,000 kg [33,069 lb] (Include Tool Magazine)	
*Specifications subject to change without notice.				