

EMTS

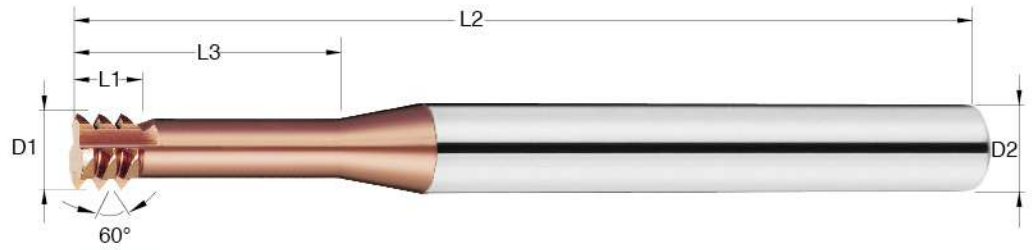

螺紋銑刀

► Internal Threading / for **H** **P** **K** **M** **S** **N** unit: mm

型號 Order No.	螺紋規格 Thread Size	直徑 Diameter D1	有效長 Effective Length L3	全長 O.A.L. L2	柄徑 Shank Dia D2	刃數 Flute
EMTS 03P050	M3x0.5	2.35	10	50	6	3
EMTS 04P070	M4x0.7	3.10	13	50	6	3
EMTS 05P080	M5x0.8	3.80	16	50	6	3
EMTS 06P100	M6x1.0	4.65	20	75	6	3
EMTS 08P125	M8x1.25	5.95	24	75	6	3

Flute Length (**L1**) = Pitch x 3

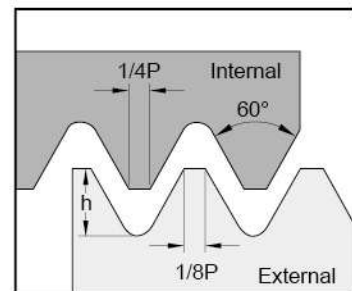
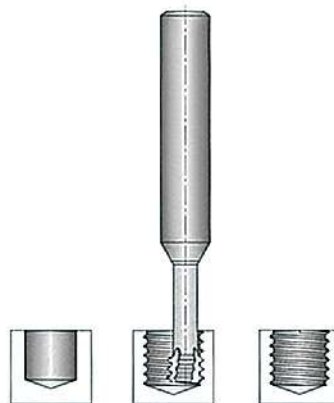

Defined by: R262 (DIN 13)
Tolerance class: 6H