

# SELF-CENTERING VISE

## Model: SC-100, 150, 200

- Designed especially for small work-pieces which require multi-direction processing
- Two-sided operation
- Ideal for small working piece

**STANDARD ACCESSORIES:**

- 2 pcs of Supporting Block
- 1 pc of Datum Plate

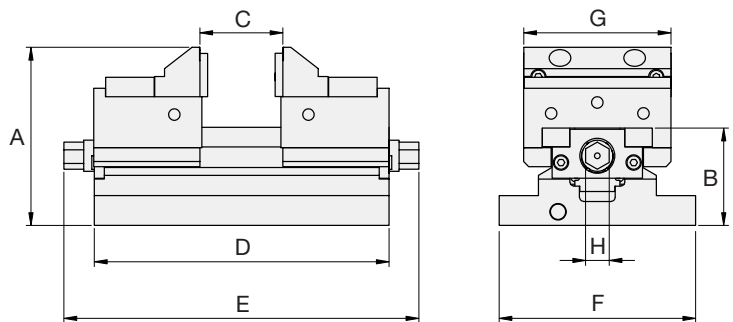
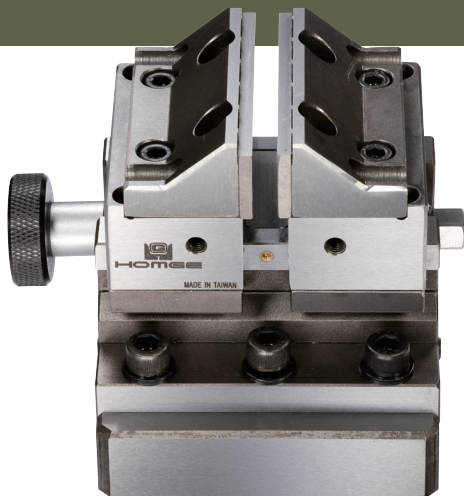
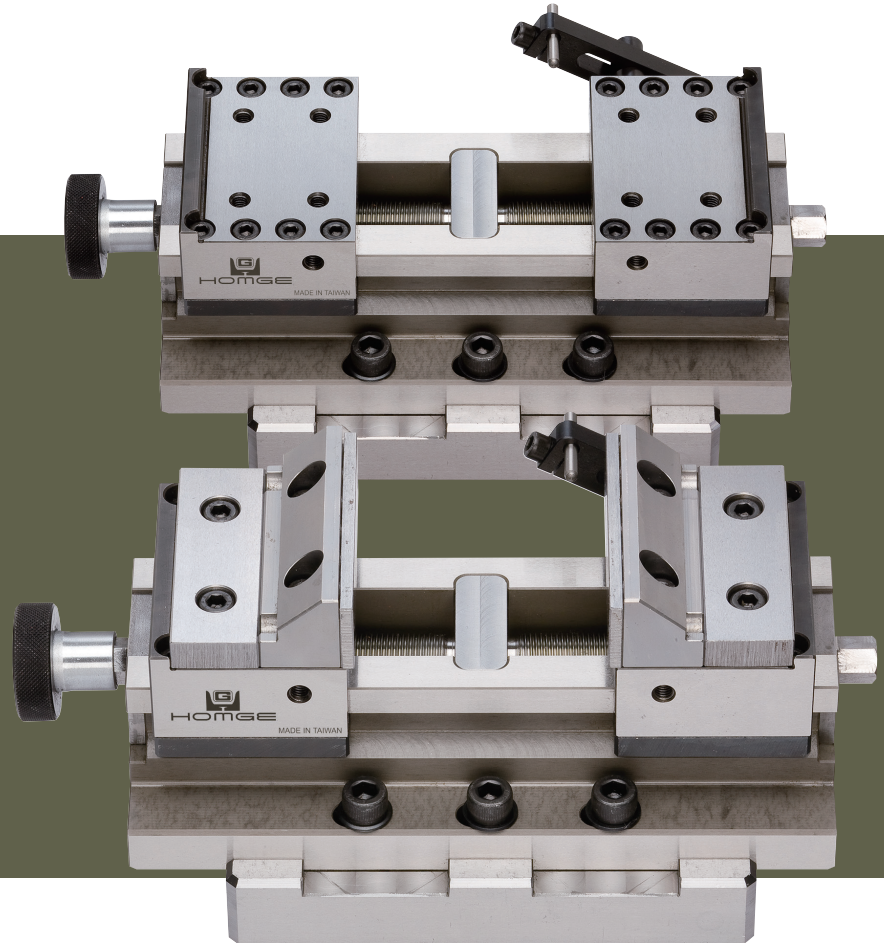

**SPECIFICATIONS** (Material: Tool Steel. Hardness: over HRC 58°)

Unit: mm

MODEL	A	B	C	D	E	F	G	H	Weight (kg)
SC-100	91	50	25	100	116	100	75	12	6
SC-150			55	150	170				8
SC-200			105	200	224				9.5