

## SGH2

功能：開槽 Grooving / 螺紋 Threading

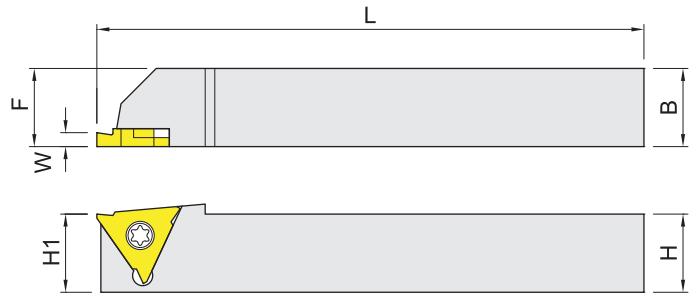

Right-hand shown

Item code	Dimensions,mm				Insert		Screw	Wrench	Weight Kg
	H (H1)	B	L	F	開槽刀片 Grooving	車牙刀片 Threading			
SGH2R-1212K-16	12	12	125	12	SMGTR 16X2... SMGTR 16X2...C	SMTTR 160360..	MS4008C	ETF10	0.15
SGH2R-1616K-16	16	16	125	16					0.26
SGH2R-2020K-16	20	20	125	20					0.42

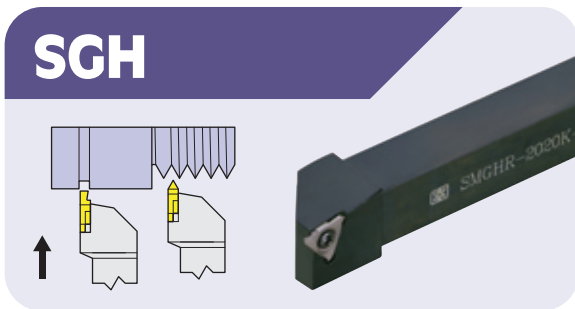

## SGH

功能：開槽 Grooving / 螺紋 Threading

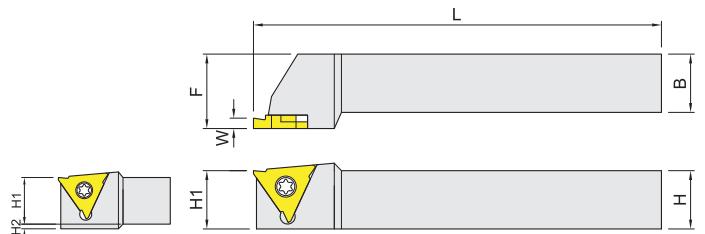

SGHR-1212K-16

Right-hand shown

Item code	Dimensions,mm					Insert		Screw	Wrench	Weight Kg
	H (H1)	B	L	H2	F	開槽刀片 Grooving	車牙刀片 Threading			
SGHR-1212K-16	12	12	125	2	16	SMGTR 16X2... SMGTR 16X2...C	SMTTR 160360..	MS4008C	ETF10	0.17
SGHR-1616K-16	16	16	125	--	20					0.29
SGHR-2020K-16	20	20	125	--	25					0.45
SGHR-2525M-16	25	25	150	--	32					0.84

※ 刀片請參考 147 頁 Please refer to page 147 for insert.

內徑車刀  
BORING BARS

外徑車刀  
TOOLHOLDERS

牙刀 & 開槽刀  
THREADING & GROOVING

銑刀  
MILLING

孔加工  
BORING TOOLS COMPONENTS

配件  
SPARE PARTS