

平面銑刀

FACE MILLS

MR
Since 1976

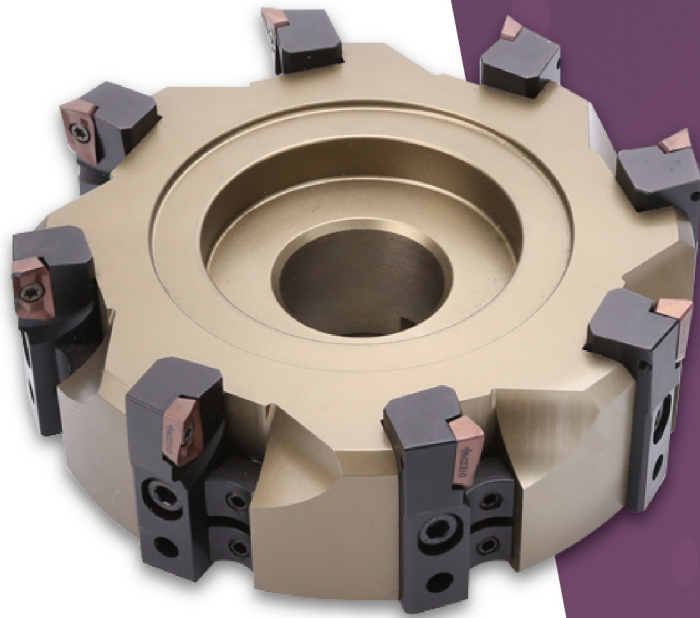

MTE3

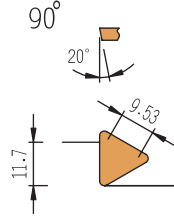

For indexable inserts
TE 1603

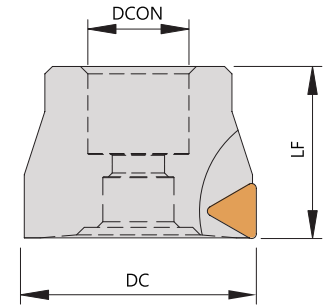

Order No.	Insert	Dimensions(mm)					Clamp	Clamp Screw	Clamp Spring	Shim	Shim Screw	Wrench
		刀徑 DC	長度 LF	孔徑 DCON		刃數 I No.						
Right / Left												
MTE3050R	TE..1603	50	46	22	-	3	CP50-3	CSB0617T	SP030	SMT32E	CSF3006	TL-25
MTE3063R		63	46	27	1"	4						
MTE3080R		80	46.5	27	1"	5						
MTE3100R		100	50	32	1-1/4"	6						
NMTE3125R	TE..1603	125	55	40	-	6	MTEL60-20	CP50-7	CS70-1	CSH0414	CS70-3	TW040
NMTE3160R		160	60	40	-	8						
NMTE3200R		200	60	60	-	12						

MTE4

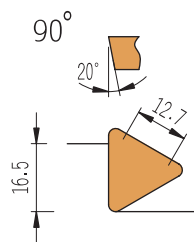

For indexable inserts
TE 2204

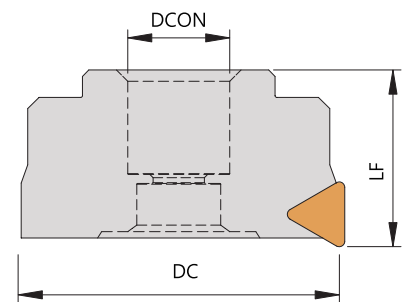

Order No.	Insert	Dimensions(mm)					Locator	Insert Clamp	Clamp Screw	Locator Screw	Washer	Wrench
		刀徑 DC	長度 LF	孔徑 DCON		刃數 I No.						
Right / Left												
MTE4080R	TE..2204	80	55	27	1"	4	MTEL60-16	CP50-7	CS70-1	CSH0414	CS70-3	TW040
MTE4100R		100	55	32	1-1/4"	5						
MTE4125R		125	55	40	1-1/2"	6						
MTE4160R		160	60	40	2"	8						
MTE4200R		200	60	60	1-7/8"	12						

MTP4



Positive Axial Rake
Radial Rake

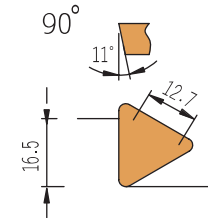

For indexable inserts
TP 2204

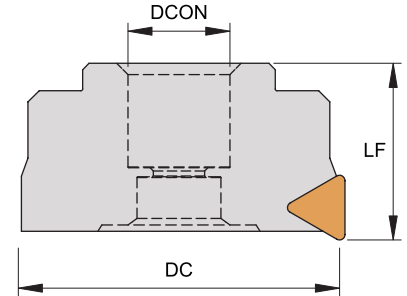

Order No.	Insert	Dimensions(mm)					Locator	Insert Clamp	Clamp Screw	Locator Screw	Washer	Wrench
		刀徑 DC	長度 LF	孔徑 DCON		刃數 I No.						
MTP4080R	TP..2204	80	55	27	1"	5	MTPL60-8	CP50-7	CS70-1	CSH0412	CS70-3	TW040
MTP4100R		100	55	32	1-1/4"	6						
MTP4125R		125	55	40	1-1/2"	8						
MTP4160R		160	60	40	2"	10						
MTP4200R		200	60	60	1-7/8"	14						
MTP4250R		250	65	60	1-7/8"	16						
MTP4315R		315	65	60	1-7/8"	18						
MTP4360R		360	65	60	1-7/8"	20						

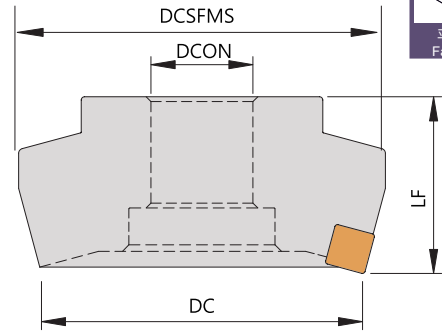
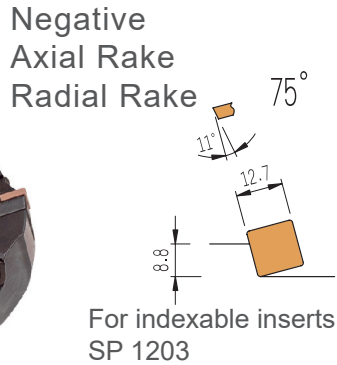
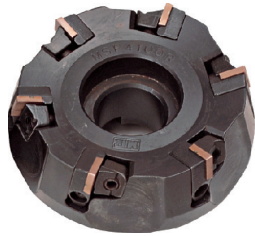

▼Recommended Inserts 刀片建議品牌: SUMITOMO

Order No.	Insert	Dimensions(mm)						Locator	Insert Clamp	Clamp Screw	Locator Screw	Washer	Wrench
Right / Left		刀徑	夾持接觸面直徑	長度	孔徑		刃數						
		DC	DCSFMS	LF	DCON	DCON (inch)	I No.						
NSP4080R	SP..1203	80	62	46	27	1"	5	NSPL60-17					
NSP4100R		100	75	51	32	1-1/4"	6						
NSP4125R		125	75	55	40	1-1/2"	8						
NSP4160R		160	128	57	40	2"	10						
NSP4200R		200	170	57	60	1-7/8"	14						
NSP4250R		250	215	57	60	1-7/8"	16						
NSP4315R		315	280	62	60	1-7/8"	18						
NSP4360R		360	331	62	60	1-7/8"	20						

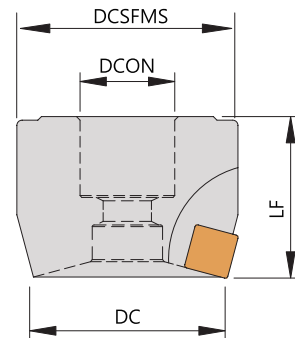
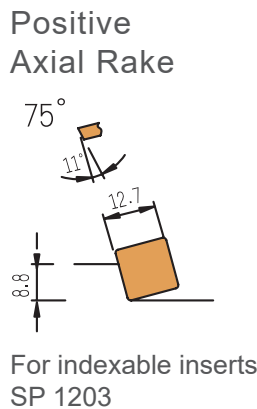

▼Recommended Inserts 刀片建議品牌: SUMITOMO

Order No.	Insert	Dimensions(mm)						Clamp	Screw	Spring	Wrench
Right / Left		刀徑	夾持接觸面直徑	長度	孔徑		刃數				
		DC	DCSFMS	LF	DCON	DCON (inch)	I No.				
SPC4050	SP..1203	50	58	46	22	-	3				
SPC4063		63	71	46	27	1"	4				
SPC4075		75	82	46	27	1"	5				
SPC4100		100	108	51	32	1-1/4"	6				



Positive Axial Rake
Radial Rake

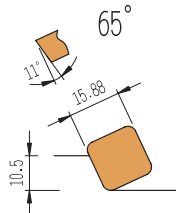

For indexable inserts
SP 1504

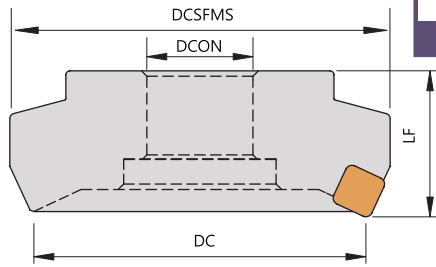

Order No.	Insert	Dimensions(mm)						Locator	Insert Clamp	Clamp Screw	Locator Screw	Washer	Wrench
		刀徑 DC	夾持接觸面直徑 DCSFMS	長度 LF	孔徑 DCON		刃數 I No.						
SP5080R	SP..1504	80	65	50	27	1"	4	SPL60-5	CP50-7	CS70-1	CSH0412	CS70-3	TW040
SP5100R		100	78	55	32	1-1/4"	5						
SP5125R		125	101	55	40	1-1/2"	6						
SP5160R		160	125	60	40	2"	8						
SP5200R		200	170	60	60	1-7/8"	10						
SP5250R		250	220	60	60	1-7/8"	12						
SP5315R		315	282	60	60	1-7/8"	14						
SP5360R		360	295	65	60	1-7/8"	16						



Positive Axial Rake
Radial Rake

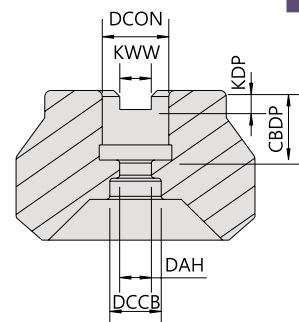
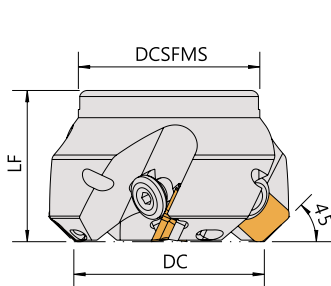

Order No.	Insert	Dimensions(mm)						Shim	Shim Screw	Locking Screw (R)	Locking Screw (L)	Wrench	
		刀徑 DC	夾持接觸面直徑 DCSFMS	長度 LF	孔徑 DCON		刃數 I No.					FT-7	TW040
SF5063R/L	SF..1504	63	60	50	22	1"	4	SMS-53	CSA4009F	CS6-0823L	CS6-0823R	FT-7	TW040
SF5080R/L		80	65	50	27	1"	5						
SF5100R/L		100	77	50	32	1-1/4"	6						
SF5125R/L		125	90	63	40	1-1/2"	7						
SF5160R/L		160	129	65	40	2"	7						

F90CN

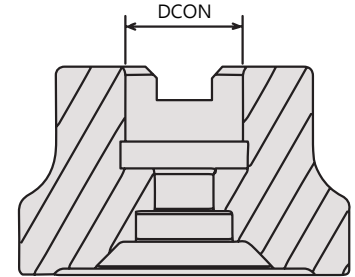
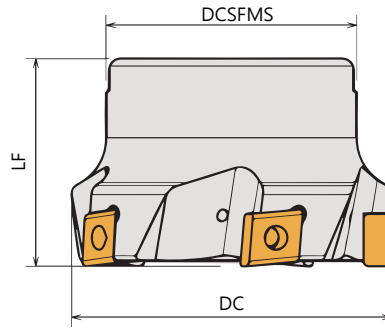

Order No.	Insert	Dimensions(mm)						Type	screw	Wrench
Right / Left		刀徑	夾持接觸面直徑	長度	孔徑		刃數			
		DC	DCSFMS	LF	DCON	DCON (inch)	I No.			
F90CN10-D40R	CNHX1005	40	35	40	16	-	3	TSCN10	CS40110	DT-15
F90CN10-D50R		50	45	40	22	-	4			
F90CN10-D63R		63	48	40	22	1"	5			
F90CN10-D80R		80	52	45	27	1"	6			
F90CN10-D100R		100	70	55	32	1-1/4"	7			

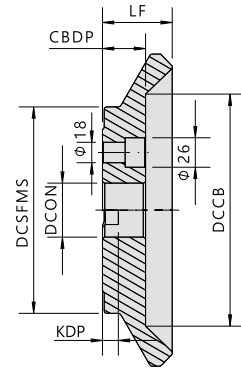
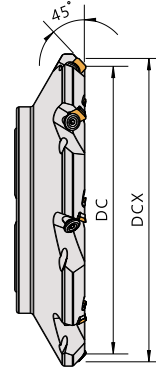
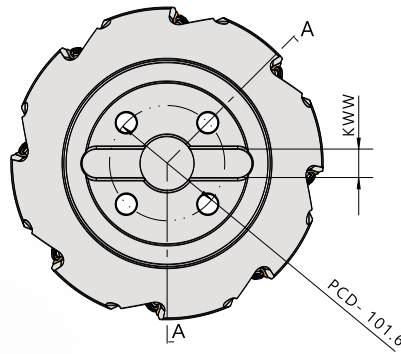

A-A

Order No.	Insert	Dimensions(mm)					Shim	Shim Screw	Locking Screw (R)	Locking Screw (L)	Wrench		
		刀徑	夾持接觸面直徑	長度	孔徑								刃數
Right / Left		DC	DCSFMS	LF	DCON	DCON (inch)	I No.						
SE4-12506R/L	SEEN1203	125	148	55	-	1-1/2"	6	SMS-42	CSA4009F	CS6-0823L	CS6-0823R	FT-7	TW040
SE4-16008R/L		160	180	60	-	2"	8						
SE4-20010R/L		200	220	60	-	1-7/8"	10						
SE4-25012R/L		250	274	63	-	1-7/8"	12						
SE4-30514R/L		305	325	65	-	1-7/8"	14						
SE4-35616R/L		356	376	63	-	1-7/8"	16						

SE445

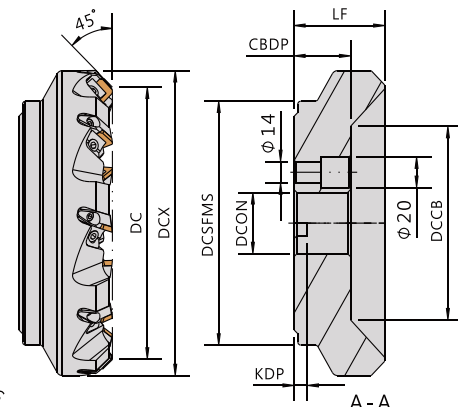
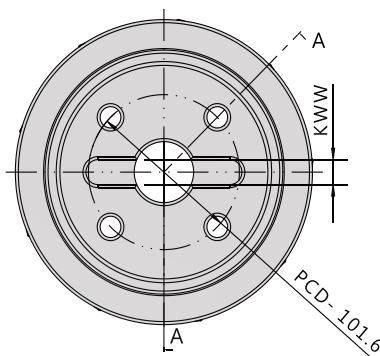

- ▼The biggest diameter 最大尺寸: 450mm
- ▼The specifications can be customized 規格可接受訂製

Order No.	Insert	Dimensions(mm)						
		刀徑	最大刀徑	夾持接觸面直徑	長度	孔徑		刃數
Right / Left		DC	DCX	DCSFMS	LF	DCON	DCON (inch)	I NO.
SE445R/L6304	SE..1203	65	83	55	51	22/27	1"	4
SE445R/L0304		78	98	70	51	27	1"	4
SE445R/L0405		100	120	80	56	32	1-1/4"	5
SE445R/L0506		126	148	102	57	40	1-1/2"	6
SE445R/L0608		160	180	120	61	40	2"	8
SE445R/L0810		199	220	182	61	60	1-7/8"	10
SE445R/L1012		254	274	220	63	60	1-7/8"	12
SE445R/L1214(M)		315/305	325/335	278	63	60	1-7/8"	14
SE445R/L1416		356	376	326	63	60	1-7/8"	16
SE445R/L0306		78	98	70	51	27	1"	6
SE445R/L0407		100	120	80	56	32	1-1/4"	7
SE445R/L0509		126	148	102	57	40	1-1/2"	9
SE445R/L0611		160	180	120	61	40	2"	11
SE445R/L0814		199	220	182	61	60	1-7/8"	14
SE445R/L1018		254	274	220	63	60	1-7/8"	18
SE445R/L1222(M)		315/305	325/335	278	63	60	1-7/8"	22
SE445R/L1426		356	376	326	63	60	1-7/8"	26

Locator		Insert Clamp		Clamp Screw	Locator Screw	Washer	Wrench
SEL60-11	SEL60-11L	CP50-7	CP50-7L	CS70-1	CSH0412	CS70-3	TW040

Order No.	Dimensions(mm)					Shim	Shim Screw	Insert Clamp	Clamp Screw	Wrench
	刀徑	夾持接觸面直徑	長度	孔徑	刃數					
Right / Left	DC	DCSFMS	LF	DCON	I No.					
SE445R 5004S	50	60	40	22	4	SMS-42	CSA4009F	CP50-7	CS70-1	TW040

SE545

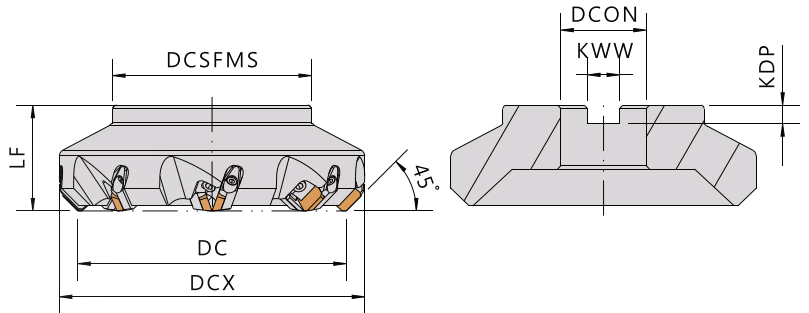

- ▼The biggest diameter 最大尺寸: 450mm
- ▼The specifications can be customized 規格可接受訂製

Order No.	Insert	Dimensions(mm)						
		刀徑	最大刀徑	夾持接觸面直徑	長度	孔徑		刃數
Right / Left		DC	DCX	DCSFMS	LF	DCON	DCON (inch)	I No.
SE545R/L0304	SE..1504	80	98	70	50	27	1"	4
SE545R/L0405		100	120	80	55	32	1-1/4"	5
SE545R/L0506		125	148	102	55	40	1-1/2"	6
SE545R/L0608		160	180	120	60	40	2"	8
SE545R/L0810		200	220	182	60	60	1-7/8"	10
SE545R/L1012		254	274	220	65	60	1-7/8"	12
SE545R/L1214		305	325	278	65	60	1-7/8"	14
SE545R/L1416		356	376	326	65	60	1-7/8"	16
SE545R/L0407		100	120	80	55	32	1-1/4"	7
SE545R/L0509		125	148	102	55	40	1-1/2"	9
SE545R/L0611		160	180	120	60	40	2"	11
SE545R/L0814		200	220	182	60	60	1-7/8"	14
SE545R/L1018		254	274	220	65	60	1-7/8"	18
SE545R/L1222		305	325	278	65	60	1-7/8"	22
SE545R/L1426		356	376	326	65	60	1-7/8"	26

Right / Left	Locator	Insert Clamp	Clamp Screw	Locator Screw	Washer	Wrench
R	SEL60-10	CP50-7	CS70-1	CSH0412	CS70-3	TW040
L	SEL60-10L	CP50-7L	CS70-1	CSH0412	CS70-3	TW040

F45SE12

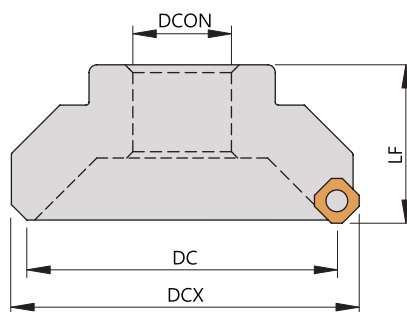

Order No.	Insert	Dimensions(mm)						Screw	Wrench
Right / Left		刀徑 DC	長度 LF	最大刀徑 DCX	孔徑 DCON DCON (inch)		刃數 I No.		
F45SE12-D050A04R/L	SEHW1204AFTN SEKT1204AF	50	40	60	22	-	4	CS45110	
F45SE12-D063A05R/L		63	50	81	22	1"	5		
F45SE12-D080A06R/L		80	50	95	27	1"	6		
F45SE12-D100B06R/L		100	50	116	32	1-1/4"	6		
F45SE12-D125B07R/L		125	63	141	40	1-1/2"	7		
F45SE12-D160C10R/L		160	63	176	40	2"	10		

F45SE13

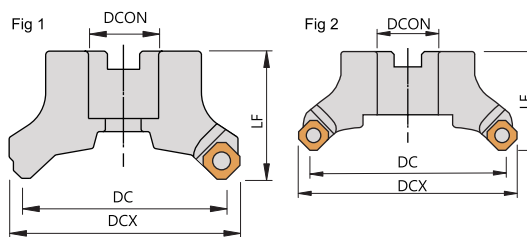

▼Recommended Inserts 刀片建議品牌: SUMITOMO & MITSUBISHI & KENAMETAL

Order No.	Insert	Dimensions(mm)							
Right / Left		刀徑 DC	長度 LF	最大刀徑 DCX	孔徑 DCON DCON (inch)		刃數 I No.		
F45SE13-D040A03R/L	SEET13T3 SEMT13T3	40	40	53	16	-	-	3	-
F45SE13-D050A04R/L		50	40	63	22	-	3	4	5
F45SE13-D063A05R/L		63	50	76	22	1"	4	5	6
F45SE13-D080A06R/L		80	50	93	27	1"	4	6	8
F45SE13-D100B07R/L		100	50	113	32	1-1/4"	5	7	10
F45SE13-D125B08R/L		125	63	138	40	1-1/2"	6	8	12
F45SE13-D160B10R/L		160	63	173	40	2"	7	10	16
F45SE13-D200C12R/L		200	63	213	60	1-7/8"	8	12	20
F45SE13-D250C14R/L		250	63	263	60	1-7/8"	10	14	24

Insert Screw	Wrench	Shim	Shim Screw	Wrench
CS35115H	DBIT-T15/DBIT-T15L	SME-42	SN5356	LW035

ex: F45SE13-D063A04Rx22, F45SE13-D080B08Rx1"

F45SN13

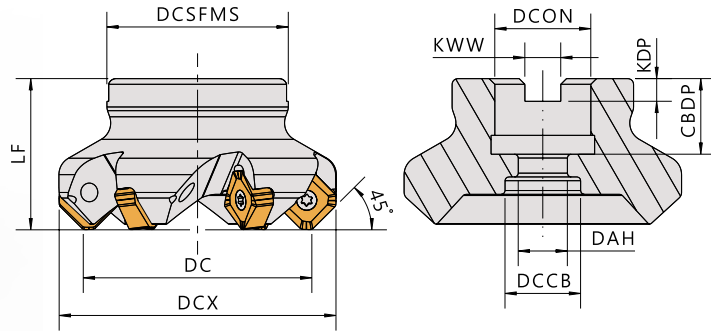
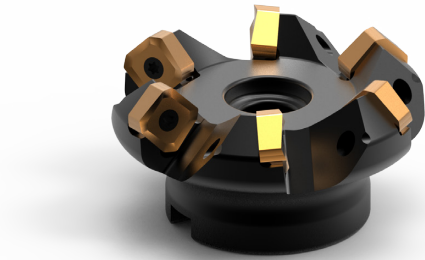
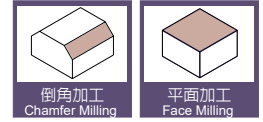

▼ Recommended Inserts 刀片建議品牌: ISCAR & ACC & WALTER

Order No.	Insert	Dimensions(mm)						Screw	Wrench
Right / Left		刀徑	長度	最大刀徑	孔徑		刃數		
		DC	LF	DCX	DCON	DCON (inch)	I No.		
F45SN13-05004	SNMX1205 SNEX1205 SNMU1205 ONMU1205	50	40	63	22	-	4	CSR5014	DBIT-T15
F45SN13-06306		63	40	76	22	1"	6		
F45SN13-08007		80	50	93	27	1"	7		
F45SN13-10008		100	50	113	32	1-1/4"	8		
F45SN13-12510		125	63	138	40	1-1/2"	10		
F45SN13-16012		160	63	173	40	2"	12		
F45SN13-20014		200	63	213	60	1-7/8"	14		
F45SN13-25016		250	63	263	60	1-7/8"	16		

鋁合金本體

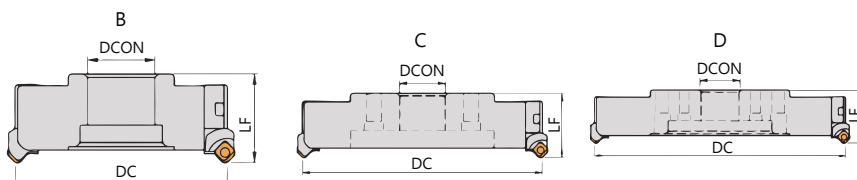
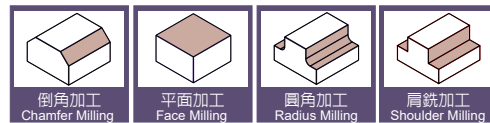

FACE MILL INTERCHANGEABLE CASSETTES
HIGH-STRENGTH ALUMINIUM BODY FOR EASY
AND PRECISE ADJUSTMENT.

Order No.	Dimensions(mm)				
Right / Left	刀徑	長度	孔徑		刃數
	DC	LF	DCON	DCON (inch)	I No.
F125B06R-Cassettes	125	65	40	1-1/2"	6
F160B08R-Cassettes	160	65	40	2"	8
F200C10R-Cassettes	200	65	60	1-7/8"	10
F250C14R-Cassettes	250	65	60	1-7/8"	14
F315D16R-Cassettes	315	73	60	1-7/8"	16
F360D18R-Cassettes	360	73	60	1-7/8"	18

Order No.	Insert	Insert Clamp Screw	Insert Wrench
Right / Left			
 S45SE12	SEHW1204 SEKT1204	CS45110	DBIT-T15
 S90AP16	SUMITOMO APMT1605	CS35090	DBIT-T15
 S90AP1604	MITSUBISHI APMT1604	CS40090	DBIT-T15
 SMORP12	MITSUBISHI RPMT1204	CS35090	DBIT-T15
 S75SP12	SPMN1203	CP50-26 CS7-5018	LW030

PARTS	Clamp Screw	Micro Adjusting Pin	Cassettes Clamp	Lock Screw	Wrench
	CS70-12	AP-01	CP50-9	CS7-6016	LW025