

功能：開槽 Grooving / 橫送 Turning / 仿型 Profiling

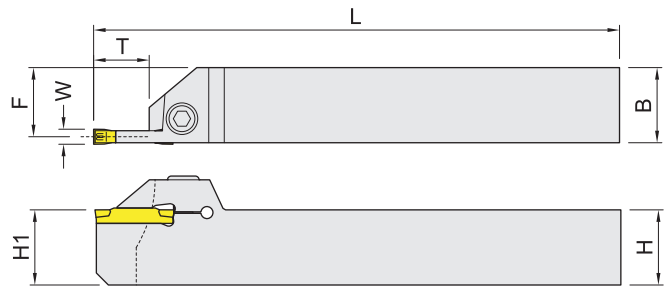

Right-hand shown

Item code	Dimensions,mm					Width W(mm)	Insert	Screw	Wrench	Weight Kg
	H(H1)	B	L	F	T					
GNDMR-1616K-312T	16	16	125	14.9	12	3.0	GCMN30...	HTMT520	ETL25	0.24
GNDMR-2020K-312T	20	20	125	18.9						0.45
GNDMR-2525M-312T	25	25	150	23.9						0.84
GNDMR-2020K-418T	20	20	125	18.5	18	4.0	GCMN40...			0.45
GNDMR-2525M-418T	25	25	150	23.5						0.84
GNDMR/L-2525M-518T	25	25	150	23	18	5.0	GCMN50...	HTM630	PL50	0.84
GNDMR/L-2525M-618T	25	25	150	22.5		6.0	GCMN60...			0.84

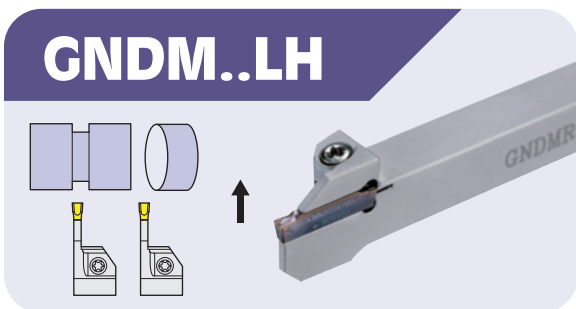

功能：開槽 Grooving / 橫送 Turning / 仿型 Profiling

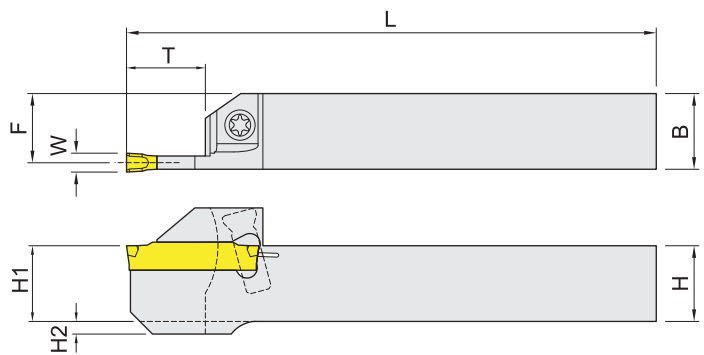

Right-hand shown

Item code	Dimensions,mm						Width W(mm)	Insert	Screw	Wrench	Weight Kg
	H(H1)	B	L	F	T	H2					
GNDMR/L-1212K-312LHT	12	12	125	10.95	12	2	3.0	GCMN30...	MS4013F	ETL15	0.15

※ 走心式刀 SWISS-TYPE

※ 刀片請參考 103 頁 Please refer to page 103 for insert.

內徑車刀  
BORING BARS

外徑車刀  
TOOLHOLDERS

牙刀 & 開槽刀  
THREADING & GROOVING

銑刀  
MILLING

孔加工  
BORING TOOLS COMPONENTS

配件  
SPARE PARTS