

NSV 106A/AM

Ultra High Performance Vertical Machining Center



NSV 106A/AM

The Beauty in Machining

The **NSV 106A/AM** ultra high performance vertical machining center represents exquisite workmanship on superb cutting performance. With robust construction, the advanced technology offers the highest level of rigidity and accuracy that is tailor-made for high productivity requirements and die & mold application.







| Motorcycle Frame |

High Performance Applications

NSV 106AS

- 48 / 48 / 48 m/min. X / Y / Z Rapid Feedrate

NSV 106AM/AMS

- Perfect for die & mold, aerospace and automotive applications.
- Ultra-high controllability and stability.

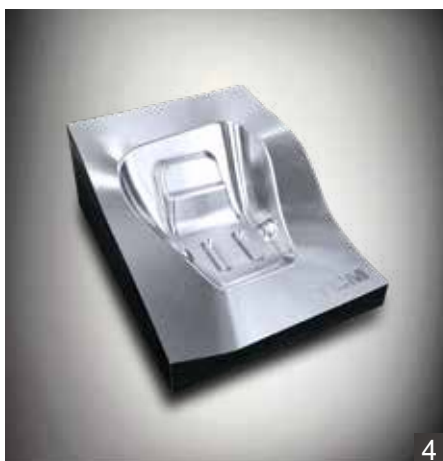

| 1-2. Motorcycle Frame | 2-3. Motorcycle Part | 4. Light Mold | 5. Pipe Mold | 6. Clutch Part |

NSV 106A/AM

NSV 106A/AM vertical machining center is specially designed for high speed and high efficiency machining applications. NSV 106A/AM is built with a large delta machine column and wide base to ensure the highest stability during high speed movement.



NSV 106A

12,000rpm
(15,000rpm)

NSV 106AS

15,000rpm

NSV 106AM

12,000rpm
(15,000rpm)

NSV 106AMS

12,000rpm
(15,000rpm)

X	48 m/min. 1,890 ipm	48 m/min. 1,890 ipm	24 m/min. 945 ipm	24 m/min. 945 ipm
Y	48 m/min. 1,890 ipm	48 m/min. 1,890 ipm	24 m/min. 945 ipm	24 m/min. 945 ipm
Z	32 m/min. 1,260 ipm	48 m/min. 1,890 ipm	16 m/min. 630 ipm	24 m/min. 945 ipm



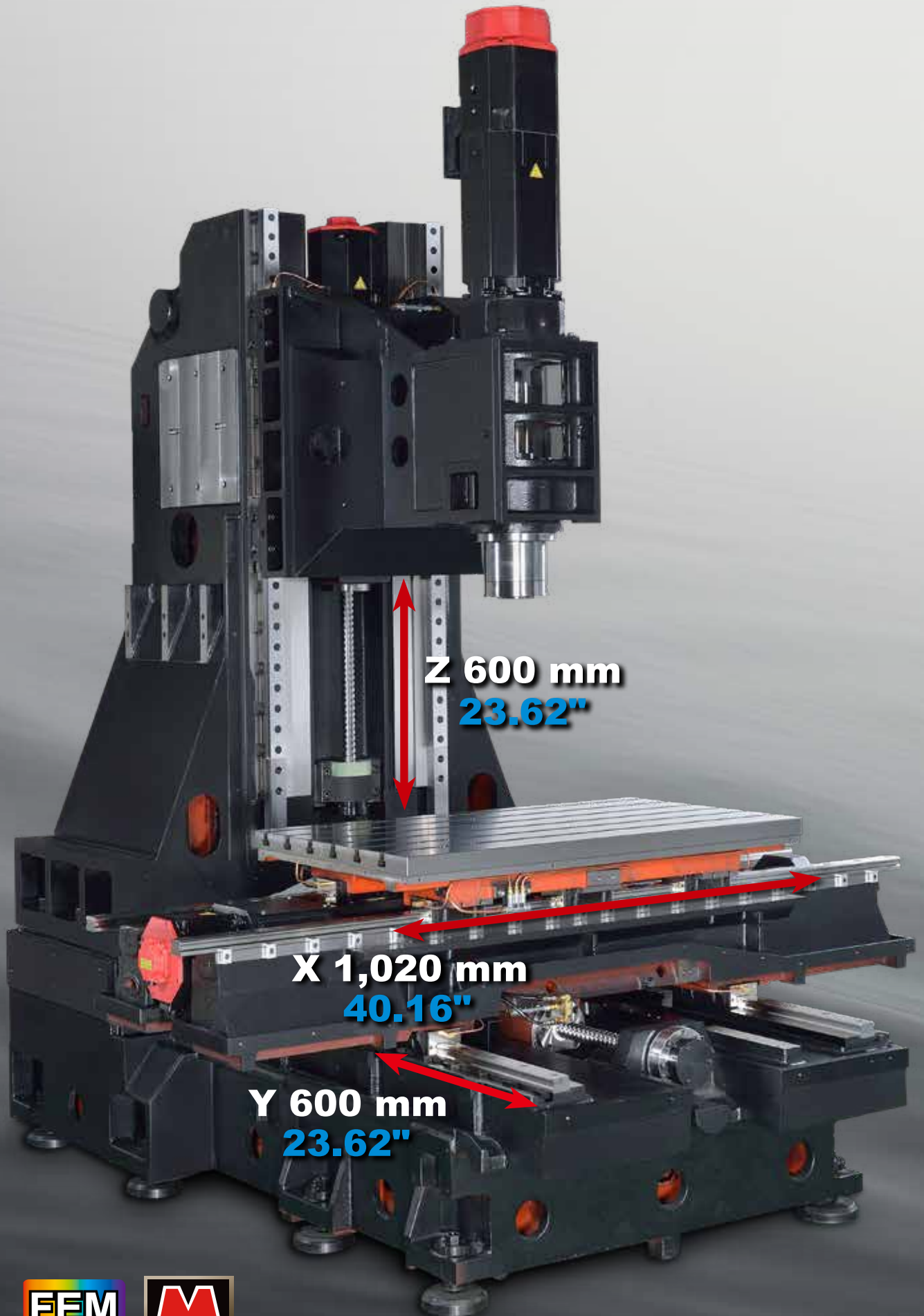

Z 600 mm
23.62"

X 1,020 mm
40.16"

Y 600 mm
23.62"

- Large delta machine column and base ensure the highest stability during high speed movement.
- Wide span of axial guideways.
- All roller type guideways (**NSV 106AS**) and wide ball screw are designed for maximum aluminum chip disposal
- Advanced FEM analysis strengthens the structure while reduces the weight to provide the best cutting rigidity.

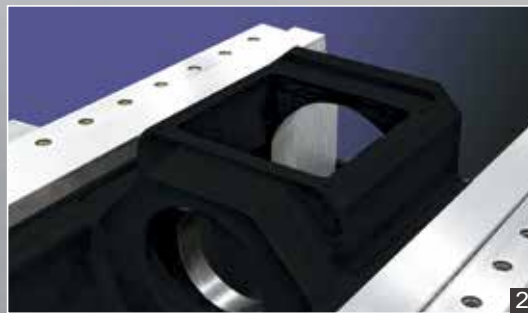

1. All roller type guideways (**NSV 106AS**)	2. One-piece Motor Housing
3. Auto tool change(T-T): 1.8 Sec.	4. 24T (30T opt.) Disk Type
5. 48T (opt.) Chain Type	6. ATC Door (opt.)

HIGH SPEED HIGH PRECISION SPINDLES

IDD Spindle Design

- The unique IDD spindle design offers smooth reliability at high speed.
- Ceramic bearings avoid the effect of spindle thermal growth.
- Maximize both spindle and tool life under hard milling conditions
- Provide low spindle vibration and optimal heat isolation that result in excellent surface finish.
- The perfect and robust axes fulfill constant machining requirement for chip removal while milling, drilling and tapping.



Cutting Capacity **BBT40** 12,000rpm Fanuc System

FACE MILL	S45C Steel
Material Removal Rate	
648	
cc/min.	
Tool	ø63 mm x 5T
Spindle Speed	1,500 rpm
Feedrate	4,500 mm/min.
Width of Cut	60 mm
Depth of Cut	2.4 mm

FACE MILL	S45C Steel
Depth of Cut	
6.5	
mm	
Tool	ø80 mm x 5T
Spindle Speed	600 rpm
Feedrate	450 mm/min.
Width of Cut	60 mm

END MILL	S45C Steel
Depth of Cut	
10	
mm	
Tool	ø32 mm x 3T
Spindle Speed	500 rpm
Feedrate	225 mm/min.
Width of Cut	32 mm

U-DRILL	S45C Steel
Cutter Diameter	
ø49	
mm	
Tool	ø49 mm x 1T
Spindle Speed	1,500 rpm
Feedrate	150 mm/min.
Depth of Cut	25 mm

TAP	S45C Steel
Tapping	
M24	
Tool	M24 x 3P
Spindle Speed	80 rpm
Feedrate	240 mm/min.
Depth of Cut	24 mm

RIGID TAP	A6061 Aluminum
Tapping	
M1.2	
Tool	M1.2 x 0.25P
Spindle Speed	1,200 rpm
Feedrate	300 mm/min.

Note: Above cutting test was performed by NSV 106A with 12,000 rpm spindle. Cutting test data for reference only.
All cutting tests are designed to demonstrate maximum machining capabilities without preserving tool life.

Power Chart

POWER TORQUE

FANUC SYSTEM

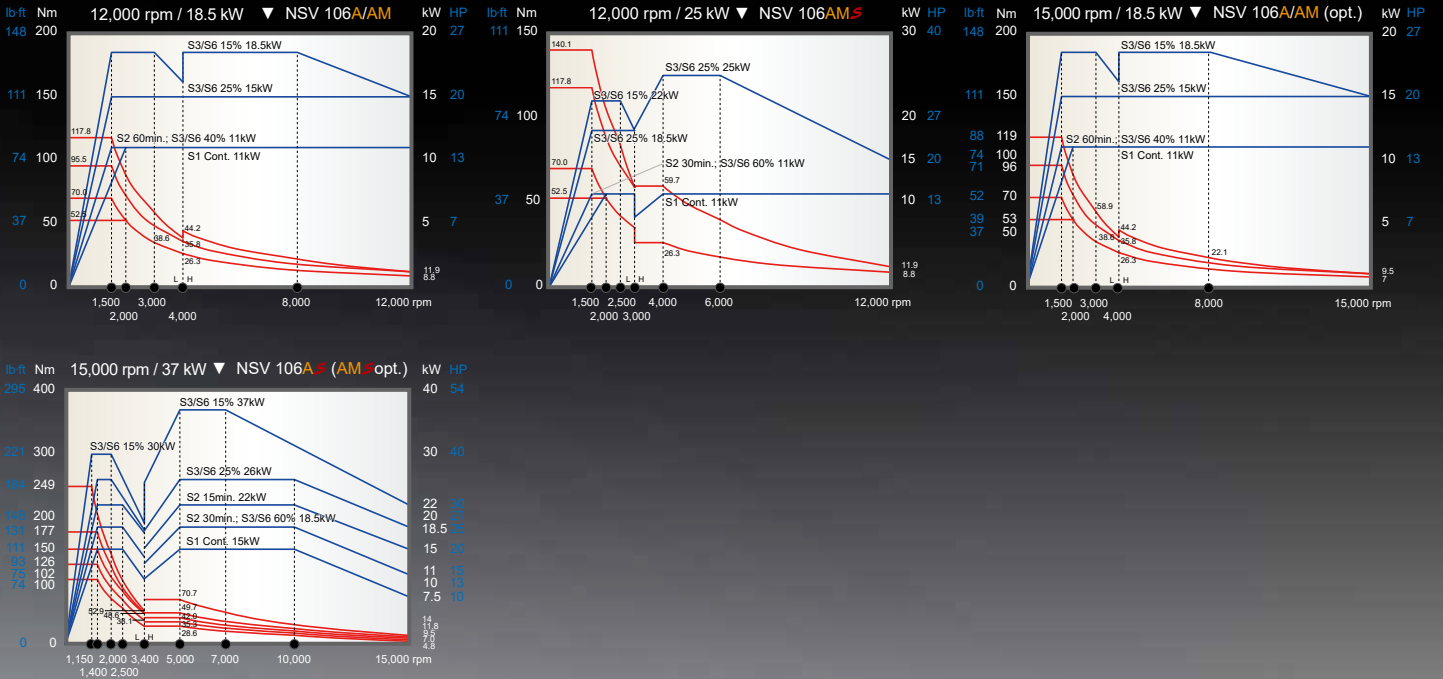

HEIDENHAIN SYSTEM

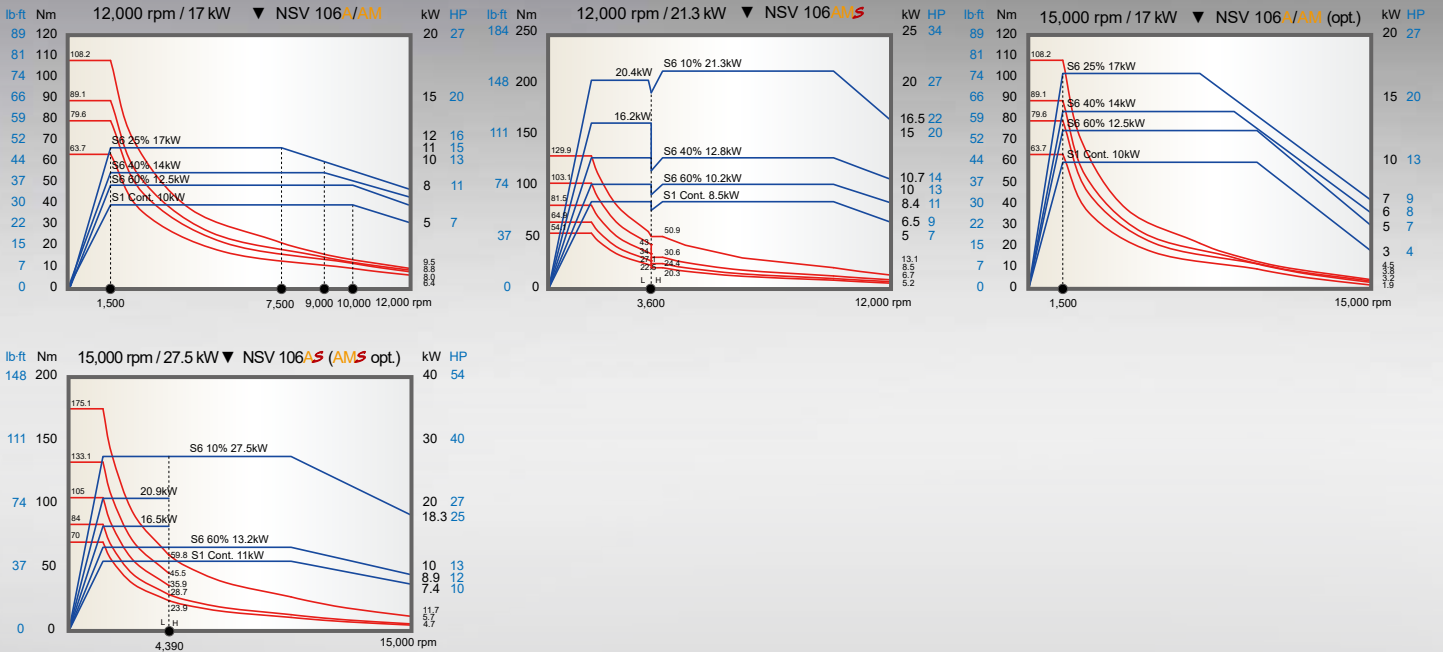

SIEMENS SYSTEM

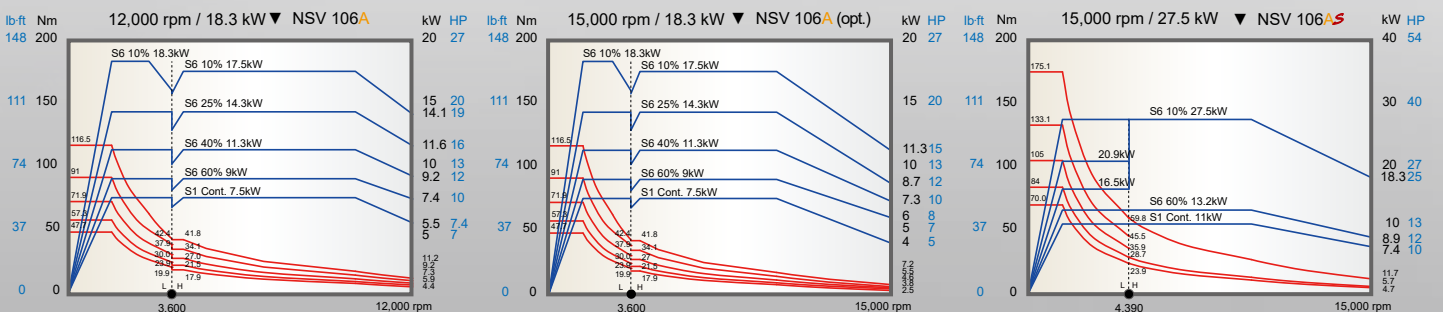



Efficient Chip Removal System

For diverse machining requirements,
NSV 106AS equipped with screw type chip conveyor
definitely help maximize the efficiency of chip removal.

*Triple-Chip Augers : **NSV 106A/AM/AMS**



Dimensions

Unit: mm inch

▼ TABLE SIZE

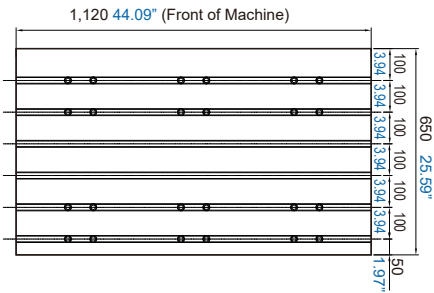

▼ T-SLOTS

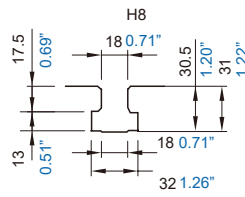

▼ TOOL SHANK

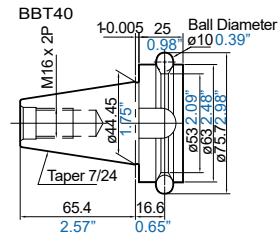

■ 24T / 30T

■ Triple-Chip Auger with 45° Pipe

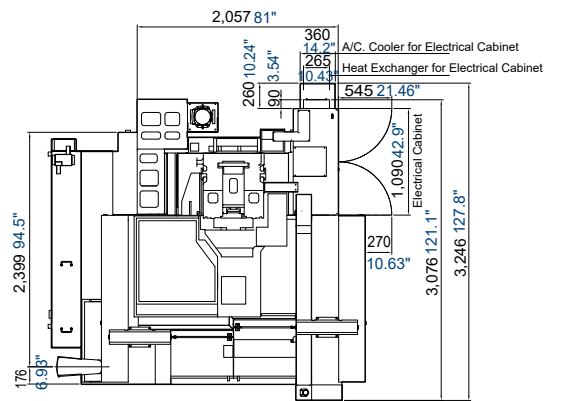
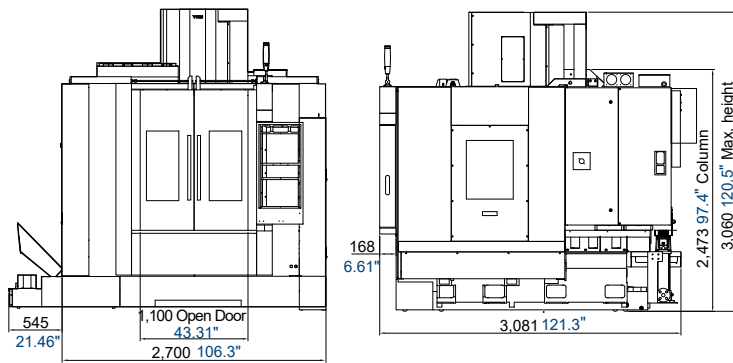

■ Triple-Chip Auger with Rear Side Chip Conveyor

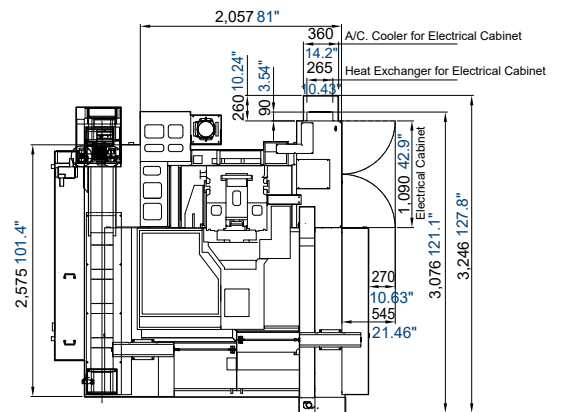
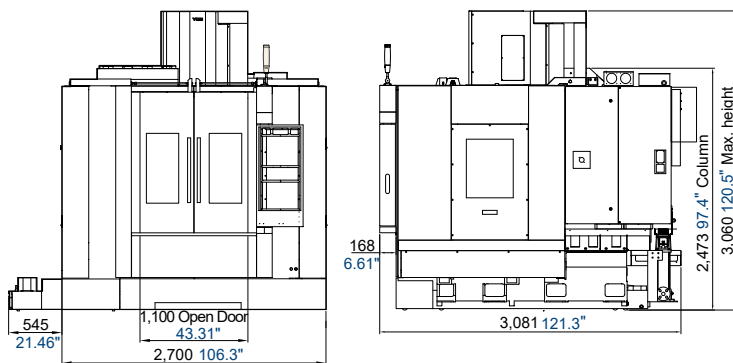

■ Dual-Chip Auger with Left-Hand Side Chip Conveyor

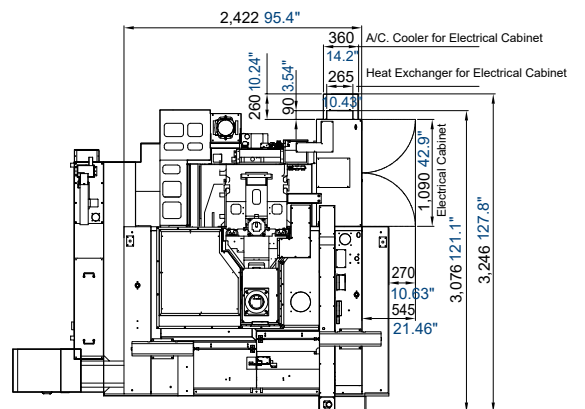
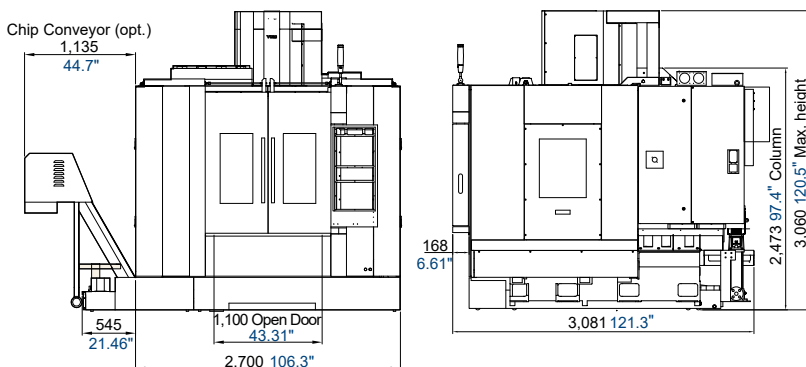



■ 48T

■ Triple-Chip Auger with 45° Pipe

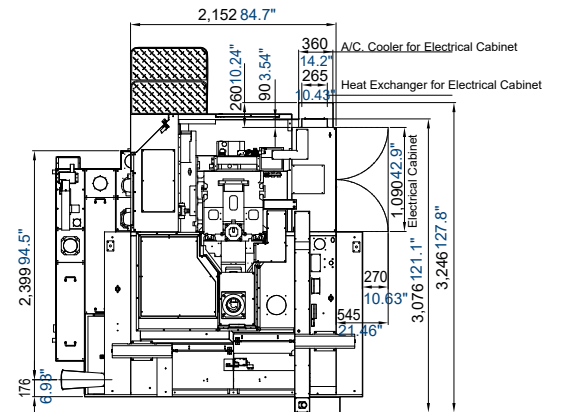
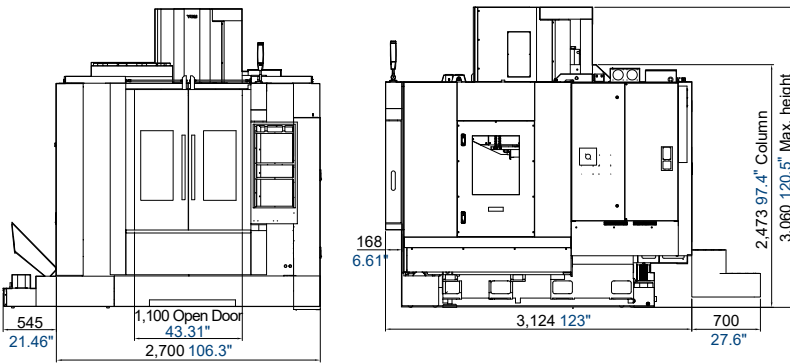

■ Triple-Chip Auger with Rear Side Chip Conveyor

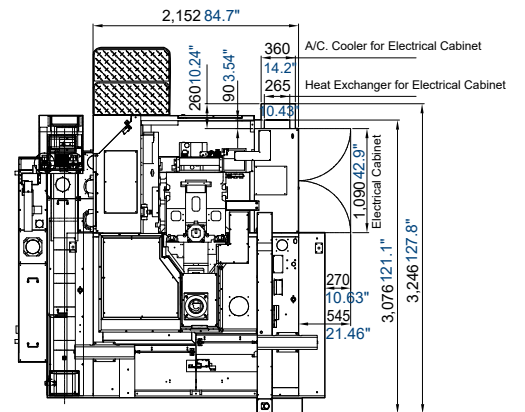
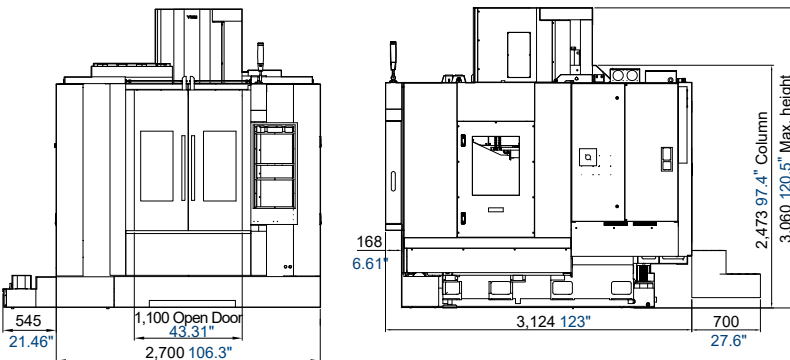

■ Dual-Chip Auger with Left-Hand Side Chip Conveyor

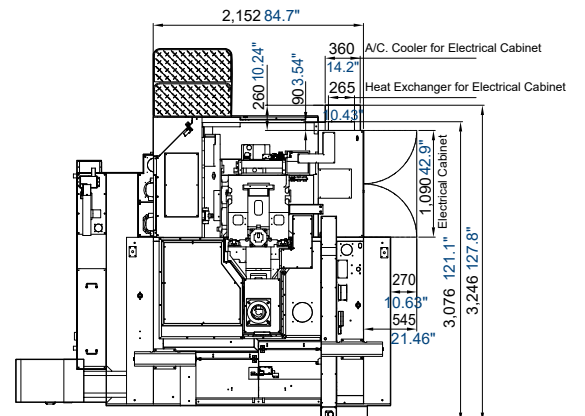
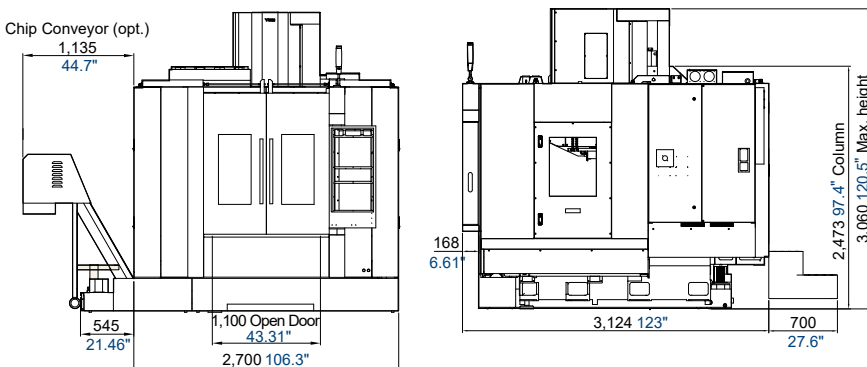

Specifications

	NSV 106A	NSV 106AS	NSV 106AM	NSV 106AMS
SPINDLE				
Spindle Speed (opt.)	12,000 rpm (15,000 rpm)	15,000 rpm	12,000 rpm (15,000 rpm)	12,000 rpm (15,000 / 20,000 rpm)
Spindle Power (opt.)	11 / 11 / 15 / 18.5 kW (11 / 11 / 15 / 18.5 kW) 15 / 15 / 20 / 25 HP (15 / 15 / 20 / 25 HP)	15 / 18.5 / 22 / 26 / 37 kW 20 / 25 / 30 / 35 / 50HP	11 / 11 / 15 / 18.5 kW (11 / 11 / 15 / 18.5 kW) 15 / 15 / 20 / 25 HP (15 / 15 / 20 / 25 HP)	11 / 25 kW (15 / 18.5 / 22 / 26 / 37 kW)(15 / 18.5 / 22kW) 15 / 34 HP (20 / 30 / 30 / 50 HP) (20 / 25 / 30 HP)
Spindle Taper	BBT40			
TRAVEL				
X / Y / Z -axis Travel	1,020 mm / 600 mm / 600 mm 40.16" / 23.62" / 23.62"			
Distance Between Spindle Nose & Table Top	100~700 mm 3.94"~27.56"			
TABLE				
Table Size	1,120 x 650 mm 44.09" x 25.59"			
No. T-slots x Size x Pitch	6 x 18 mm x 100 mm 6 x 0.71" x 3.94"			
Max. Load on Table	700 kg 1,543lb	1,000 kg 2,205 lb	700 kg 1,543lb	1,000 kg 2,205 lb
FEEDRATE				
Rapid Feedrate (X/Y/Z)	48 / 48 / 32 m/min. 1,890 / 1,890 / 1,260 ipm	48 / 48 / 48 m/min. 1,890 / 1,890 / 1,890 ipm	24 / 24 / 16 m/min. 945 / 945 / 630 ipm	24 / 24 / 24 m/min. 945 / 945 / 945 ipm
Cutting Feedrate	1~20,000 mm/min. 0.04 ~787 ipm		X / Y:1~20,000 mm/min. Z:1~16,000 mm/min. X / Y:0.04 ~787 ipm Z:0.04 ~630 ipm	1~20,000 mm/min. 0.04 ~787 ipm
ACCURACY				
	ISO 10791-4		YCM*	
Axial Travel	Full Length			
Positioning (X / Y / Z) A	0.032 / 0.025 / 0.025 mm 0.00126" / 0.00098" / 0.00098"		0.01 / 0.01 / 0.01 mm 0.00039" / 0.00039" / 0.00039"	
Repeatability (X / Y / Z) R	0.018 / 0.015 / 0.015 mm 0.0007" / 0.00059" / 0.00059"		0.007 / 0.007 / 0.007 mm 0.00028" / 0.00028" / 0.00028"	
*All values shown above are measured for the machine in good air-conditioned environments.				
ATC				
Tool Magazine Capacity (opt.)	24T (30T / 48T)	30T (48T)	24T (30T / 48T)	24T (30T / 48T)
Max. Tool Weight (per piece)	6kg 13.2 lb			
Max. Tool Dimensions	ø76 x 300 mm ø3" x 11.8"			
Max. Tool Dimensions (w/o adjacent tools)	ø125 x 300 mm ø4.9" x 11.8"			
Tool Change Method	Arm Type			
Tool Selection Method	Random			
GENERAL				
Pneumatic Supplier	6 kg/cm ² 78.2 psi			
Machine Weight	7,000 kg 15,432 lb			

Note: Above specifications may vary depending on the machine and the surrounding environment.
The manufacturer reserves the right to modify the design, specifications, mechanisms, etc., to improve the performance of the machine without notice.
The test data provided in this catalog is performed under specific test procedures and environmental conditions.

Accessories

●: Standard ○: Option -: None

	NSV 106A	NSV 106AS	NSV 106AM	NSV 106AMS
	12,000rpm 18.5 kW	15,000rpm 30kW	12,000rpm 18.5 kW	12,000rpm 22 kW
Tool Kit / Work Lamp / Pilot Lamp	●	●	●	●
Coolant Gun	●	●	●	●
Air Gun	●	●	●	●
Coolant Equipment System	●	●	●	●
Cutting Air Blast	●	●	●	●
Spindle Air Blast	●	●	●	●
Spindle Air Seal	●	●	●	●
Oil Skimmer	●	●	●	●
CTS (Coolant through Spindle)(20 Bar)	○	●	○	○
Spindle Cooling System	○	●	●	●
Oil-mist Cutting System	-	-	○	○
Circular Coolant Nozzle	●	●	●	●
Heavy Duty Coolant Pump	●	●	●	●
Chip Conveyor	○	● (Chain Type)	○	○
Triple-Chip Augers	●	-	●	●
Dual-Chip Augers	○	●	○	○
Guideway Cover (X / Y / Z)	●	●	●	●
Automatic Power Off	●	●	●	●
Automatic Door	○	○	○	○
ATC Door	○	○	○	○
Safety Door	●	●	●	●
Heat Exchanger for Electrical Cabinet	●	●	●	●
A/C. Cooler for Electrical Cabinet	○	○	○	○
Mechanical, Electrical and Operating Manuals	●	●	●	●
Foundation Bolts	○	○	○	○
Leveling Blocks & Screws	●	●	●	●
Optical Scale	○	○	○	○
Auto Tool Length Measurement System	○	○	○	○
Automatic Workpiece Measurement System	○	○	○	○
Oil-mist Collector	○	○	○	○
Full Chip Enclosure	●	●	●	●
Full Chip Enclosure (Back Cover)	○	○	○	○
CE	○	○	○	○
CNC Control : MXP-200FB ⁺	●	●	●	●
CNC Control : MXP-200FC	-	○	-	○
CNC Control: HEIDENHAIN TNC620	○	-	○	-
CNC Control: HEIDENHAIN TNC640	-	○	○	○
CNC Control: SIEMENS 828D	○	○	-	-

Note: Above specifications may vary depending on the machine and the surrounding environment.
The manufacturer reserves the right to modify the design, specifications, mechanisms, etc., to improve the performance of the machine without notice.
The test data provided in this catalog is performed under specific test procedures and environmental conditions.

YCM[®]

MXP-200FB+

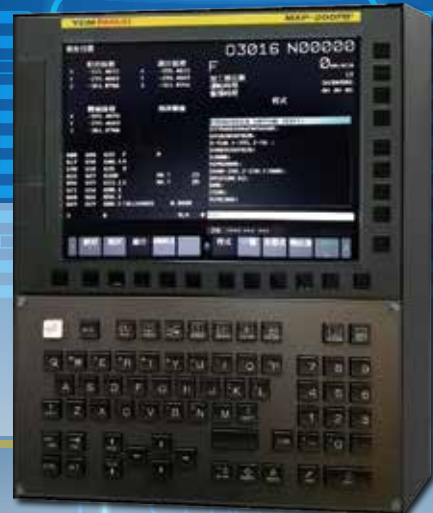

by **FANUC**

Communication Interface

RJ45 Ethernet
USB
CompactFlash Card

Excellent Vision Quality

10.4" LCD display

User-Friendly Design

Detachable keyboard
(QWERTY)

Fine Surface Technology

1. AICC II+, high precision and high accuracy AI contour control
2. Smooth tolerance control+
3. Machining quality level adjustment function

Fast Cycle Time Technology

1. Maximum 400 blocks of look-ahead for pre-calculating the machining program
2. Block processing time 1ms for achieving high-speed machining requirement
3. Smart rigid tapping function combined with spindle capability for high-speed machining (*Note)

Program Dynamic Simulation

Manual Guide i features dynamic simulation of machining programs with full-screen display

Upgraded Memory and File Organization

1. 2 MB program storage size
2. Built-in memory card for easy program editing
3. Directory filing structure with organized file management
4. 400 pairs of tool offset, 1,000 registrable programs, 48 pairs of workpiece coordinate system, 256 pairs of tool life management

*Note: Applicable to vertical machining centers with IDD spindle and built-in motorized spindle.

YCM®

i-OPERATION

Exclusive Software from **YCM**

Plus II



Pre-Machining



Intelligent Tool Data Management

Comprehensive tool data management function allows operators to monitor and manage all positions in tool magazine

Workpiece Coordinate Calculation

Conversational window provides convenient and fast setup of workpiece coordinates

RENISHAW GUI System
(Conversational Graphic Operating Interface)
(This function may vary on TCV and NH/H series machine.
For more details, please contact YCM sales representatives.)



Tool Measurement & Measurement Calibration



Workpiece Measurement (applicable to certain models)

Program Editing

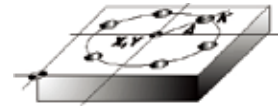

CIRCULAR HOLE PATTERN
(G120 P1) Function

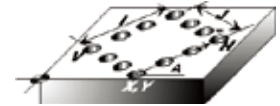

RECTANGULAR HOLE PATTERN
(G120 P4) Function

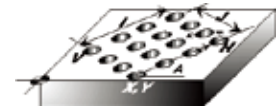
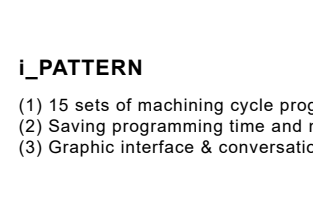

GRID HOLE PATTERN
(G120 P5) Function

i_PATTERN

- (1) 15 sets of machining cycle program
- (2) Saving programming time and memory time
- (3) Graphic interface & conversational command input

Machining



High Performance Machining Mode M300

With 5 sets of parameter settings, it's easy to find suitable and optimized machining.



Tool Load Management

Instant tool load monitoring with alarm function
(This function may vary on TCV and NH/H series machine. For more details, please contact YCM sales representatives.)



Tool Life Management

Indicating tool status of each group with tool life alarm
(This function may vary on TCV and NH/H series machine. For more details, please contact YCM sales representatives.)



Multi-Display Function

Displaying 4 statuses simultaneously with configurable status display

Smart Control Panel



iPANEL

Easy to set up and operate important functions

(This function may vary on TCV and NH/H series machine.
For more details, please contact YCM sales representatives.)

Intelligent Counter



Instantly providing users with periodic maintenance notifications and work-pieces counter management

*Above functions may vary from model to model.



YEONG CHIN MACHINERY INDUSTRIES CO., LTD.

No. 888, Sec. 1, Homu Road, Shengang District, Taichung 42953, Taiwan

Tel : +886-4-2562-3211

Fax: +886-4-2562-6479

Web Page: WWW.YCMCNC.COM

Email: sales@YCMCNC.COM



202205-E05-2000