

# 鑽頭研磨機 Drill Re-sharpening Machine



Model	YD-213	YD-320
Dimension	260 x 160 x 160 mm	
Capacity	2-13 mm	3-20 mm
Weight	8 kg	
Speed of wheel	5000 ± 300 rpm	
Motor voltage	220 V	
Grinding wheel	CBN: for HSS SD: for Tungsten, Carbide (choose one)	
Accessories	ER20 collet 2-13 mm Extension rod x 2 Hex wrench x 2 Power cord	same YD-213 plus+ ER25 collet 14-20 mm ER25 chuck set

## 操作說明 Operating Manual

1.

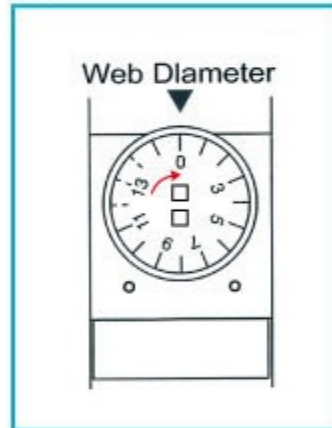

2.

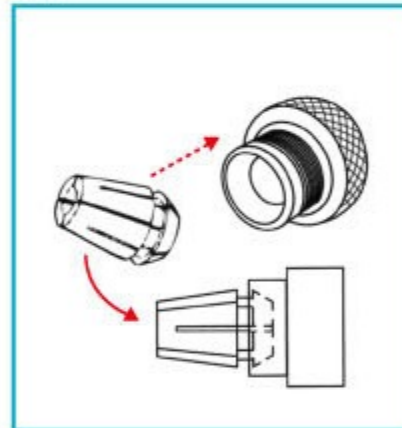

3.

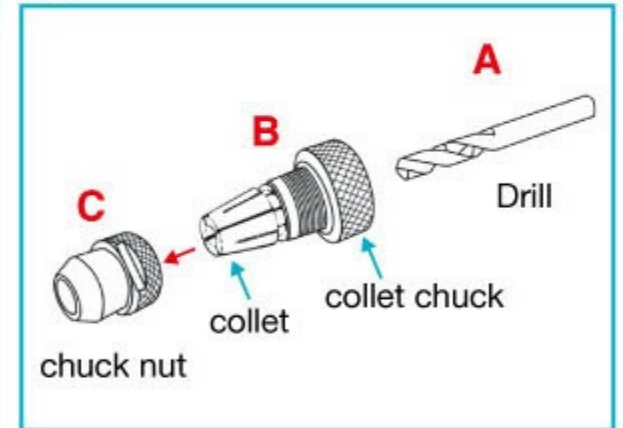

4.



5.



6.

