

ITEM	VL-V8	VL-V10		
<b>Travel</b>				
X - Axis Travel	800mm	1000mm		
Y - Axis Travel	500mm	600mm		
Z - Axis Travel	500mm	560mm		
Spindle Nose To Table	120-620mm	150-710mm		
Spindle Center To Z - Rail	525mm	650mm		
<b>Table</b>				
Table Size	900mmX420mm	1120mmX600mm		
T - Slot (number*width*pitch)	3X14mmX100mm	5X18mmX100mm		
Maximum Table Load	400kg	800kg		
<b>Spindle</b>				
Spindle Taper	BT-40			
Type Of Driving	Belt Type			
Spindle RPM	50-10000 rpm			
<b>Feed Rate</b>				
X, Y Axis Rapid Feed Rate	36m/min			
Z Axis Rapid Feed Rate	36m/min			
X, Y, Z Max.Cutting Feed Rate	10m/min			
<b>Automatic Tool Changer(ATC)</b>				
Armless Type (Tool to Tool)	16T			
Arm Type (Tool to Tool)	24T			
Max. Tool Diameter*Adjacent (with neighbor)	Φ150X300mm (Φ78 X 300mm)			
Max. Tool Weight	8 kg			
<b>Motors</b>				
	<b>MITSUBISHI</b>	<b>FANUC</b>	<b>MITSUBISHI</b>	<b>FANUC</b>
Spindle Motor (RATED / MAX)	5.5kw / 7.5kw	7.5/11kw	7.5 kw/11kw	11/15kw
X, Y Axis Servo Motor	1.5kw	1.8kw	2.0kw	3.0kw
Z Axis Servo Motor	3.0kw BS	3.0kw BS	3.0kw BS	3.0kw BS
<b>Machine Accuracy</b>				
Positioning Accuracy (JIS)	± 0.005mm / 300mm			
Repeat Poitioning Accuracy (JIS)	± 0.003mm			
<b>Other</b>				
Approximate Weight	4500 KG	6800 KG		
Floor Space Measurement (JIS)	2280mm X 2800mm X 2590mm	2930mm X 3300mm X 2850mm		

### Standard Features

- BT-40 Belt Type Spindle 10000rpm
- Air blast through spindle
- Work lamp
- three color light
- Auto power off
- Auto lubrication system
- Rigid tapping
- RS232 interface
- CF card interface
- Remote manual pulse generator
- Heat exchanger for control cabinet
- High pressure water & air gun
- Chip flush
- Full splash guard
- Operation & Procedure Manuals
- Machine manual
- Leveling pads & bolts
- Tool box & Tool

### Optional Features

- 4th Axis (Ø125/170/210 )
- Spindle coolant system
- Spindle coolant ring system
- Tool length measurement system
- Geneva Type ATC (16T)
- Arm type ATC (24T)
- Chain type conveyor with car

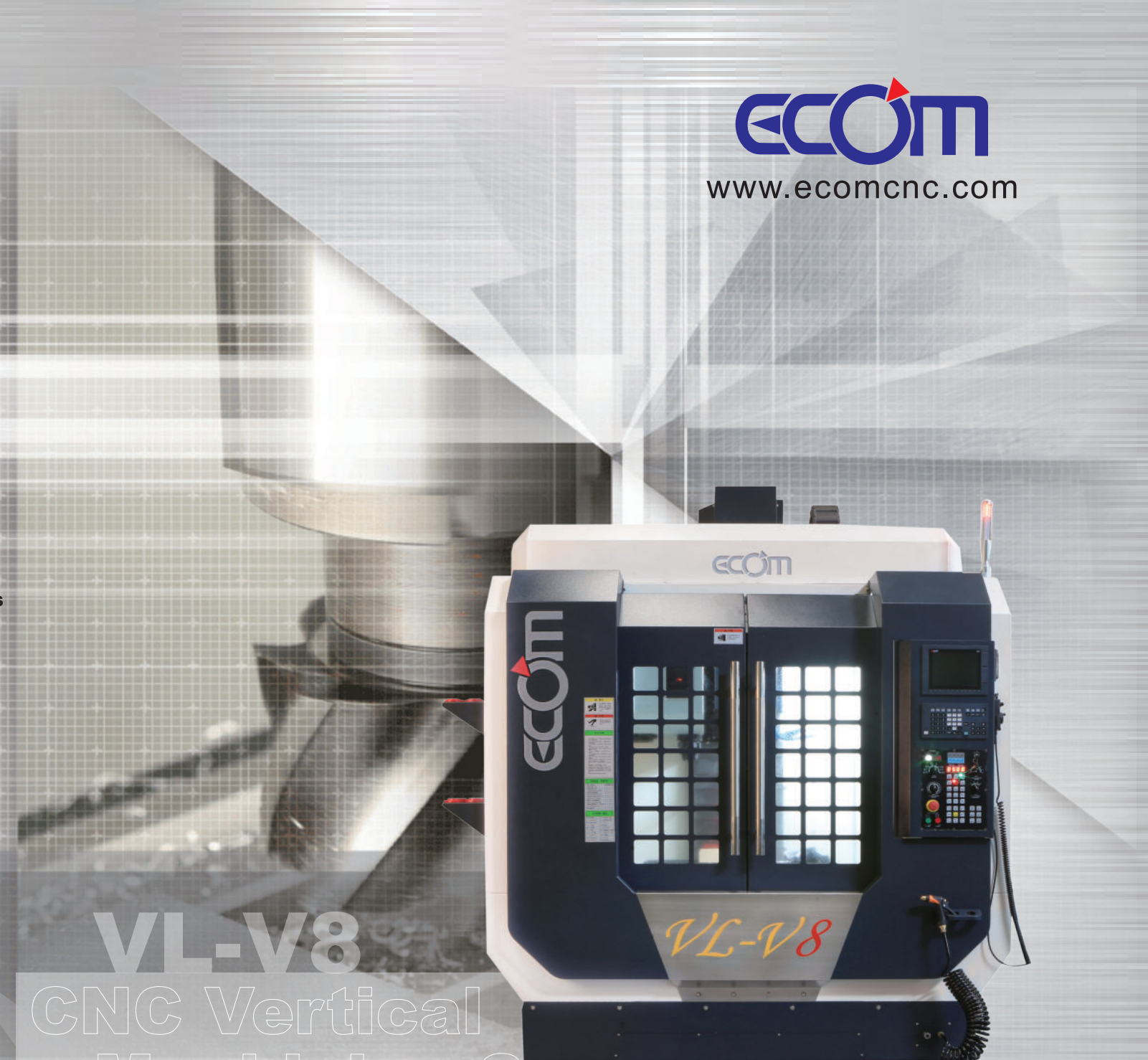

# VL-V8 CNC Vertical Machining Center

## Metal Production Expert

### ECOM PRODUCTS



Vertical Tapping Center    Vertical Machining Center (i series)    Vertical Machining Center (BT50 series)    Horizontal Machining Center    Double Column Machining Center



#### ECOM TAIWAN

TEL : +886-4-7389907  
 FAX : +886-4-7382139  
 ADD : No.563, Sec. 3, Zhongshan Rd.,  
 Changhua City, 500, Taiwan  
 E-mail : ecomcnc.tw@hotmail.com

#### ECOM CHINA

TEL : +86-596-7672668  
 FAX : +86-596-7672636  
 ADD : No. 87, Qiaodong Rd., Fengtian Town,  
 Nanjing County, Zhangzhou City,  
 Fujian Province, China





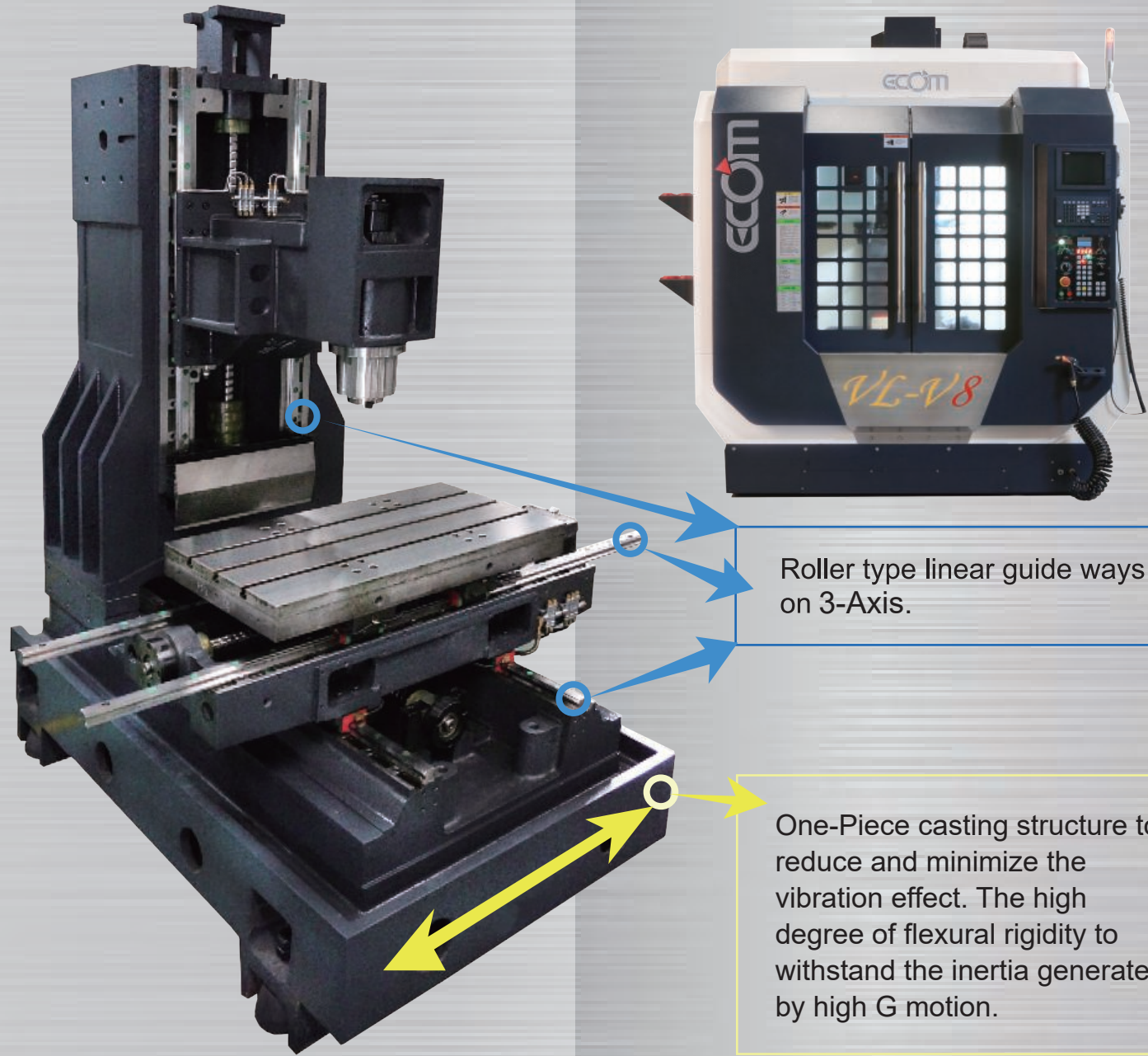

Roller type linear guide ways on 3-Axis.

One-Piece casting structure to reduce and minimize the vibration effect. The high degree of flexural rigidity to withstand the inertia generated by high G motion.

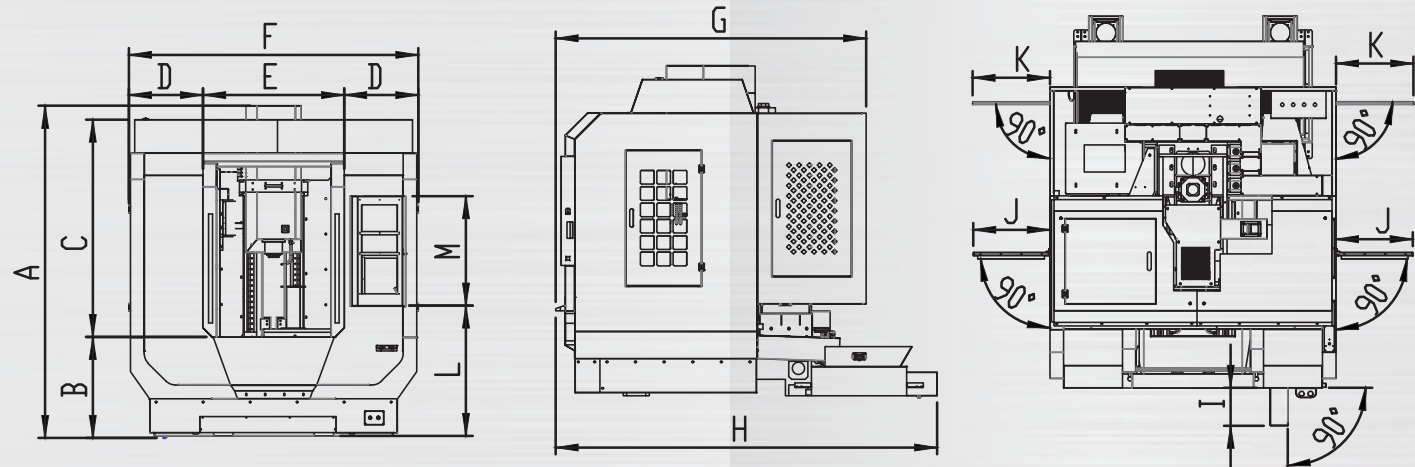

Model	A	B	C	D	E	F	G	H	I	J	K	L	M	N	O
VI - V8	2380	725	1350	535	1035	2100	2280	2830	280	565	570	290	470	450	380



a Roller type linear guide ways on 3-Axis.

b 6 Heavy-Duty roller blocks on X/Z-Axis.

c 3-Axis design with precision  $\psi 40$  ballscrew

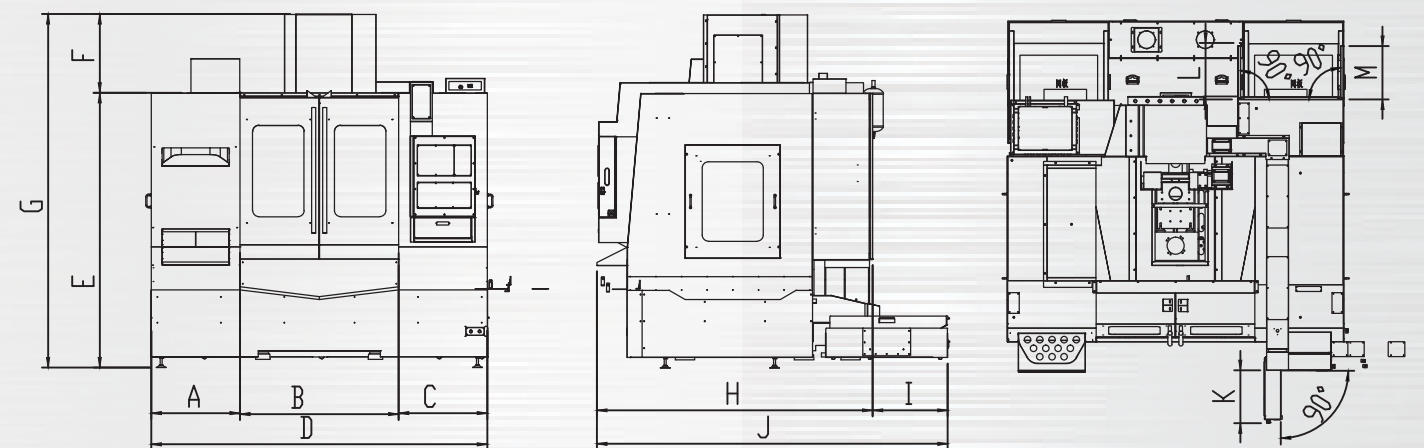

Model	A	B	C	D	E	F	G	H	I	J	K	L	M
VI-V10	725	1300	725	2750	2250	645	2895	2260	620	2880	435	465	440