

Shung Dar YouTube Facebook

| MODEL 機型 | |
|--------------------------|--|
| Coil Width 材料寬度 (mm) | 1250 / 1550 / 1830 / 2000 |
| Coil Thickness 材料厚度 (mm) | 0.3~2.0 / 0.5~3.2 / 0.8~4.0 / 1.0~6.0 / 2.0~8.0 / 3.0~10.0 / 6.0~12.0 mm |
| Coil Weight 材料重量 (Tons) | 10 / 15 / 20 / 25 / 30 / 35 Tons |

- ◆ The specification is available to customer's requirement .
- ◆ 可依客戶使用需求，製造特殊規格。

| FEATURE | 特性 |
|---------|----|
|---------|----|

- ◆ Entry Coil Car.
- ◆ Loading coil to uncoiler mandrel.
- ◆ Drive by hydraulic motor.

- UNCOILER**
- ◆ Coil ID ϕ 508, ϕ 610 & ϕ 760 mm.
 - ◆ The mandrel driven by AC motor for threading/rewinding.
 - ◆ CPC is option.

- STRAIGHTENER (OPTION)**
- ◆ Straightening the radian of coil.
 - ◆ Gearbox with universal joints to work rolls.

- FRONT SHEAR UNIT**
- ◆ To cut head material or unused material to wind back.

- NO.1 LOOP TABLE**
- ◆ Loop table can be leaded head coil to next machine.
 - ◆ Photo sensor is controlled straightener's speed.

- SLITTER**
- ◆ Double slitters' design is option.
 - ◆ It can save time to set slitting blades.
 - ◆ The exchange of double slitters is AC motor.

- COIL END HOLDER & SCRAP RE-WINDER**
- ◆ To hold the end of coil strips preventing to fall into pit.
 - ◆ Re-winding edge of scrap material.

- NO. 2 LOOP TABLE**
- ◆ Loop table can be leaded head coil to next machine.

- TENSION UNIT**
- ◆ By dual hydraulic pressure adjustable regulators to control it.
 - ◆ Defective roller to measure strip length.
 - ◆ Adopting changeable felt to protect strips surface.
 - ◆ Belt type is option.

- END SHEAR UNIT (OPTION)**
- ◆ To divide mother coil to several small coils.

- RECOILER**
- ◆ Re-coiling slitting strip to coil.
 - ◆ Gapless paddle design as option.
 - ◆ Coil ID ϕ 508 mm or ϕ 610 mm.

- EXIT COIL CAR**
- ◆ To move out re-coiling coils from mandrel.

- TURNSTILE**
- ◆ To save coils moving out and handling time.

- ◆ 上卷台車。
- ◆ 將料卷放置在料架上。
- ◆ 使用油壓馬達驅動。

- 開卷機**
- ◆ 料卷內徑 ϕ 508、 ϕ 610 及 ϕ 760 mm。
 - ◆ 料架主軸採用AC馬達驅動，主軸可以 正轉/逆轉操作。
 - ◆ 選購：料架自動中心校正。

- 矯正機**
- ◆ 矯正鐵板弧度。
 - ◆ 齒輪箱採用萬向接頭傳動滾輪。

- 前段剪床**
- ◆ 切去料頭的不良品及未使用完的材料做回收。

- No.1 渡橋**
- ◆ 備料渡橋引導材料進入下一台機器。
 - ◆ 備料區光電控制。

- 分條機**
- ◆ 選購：雙刀座，可節省換刀的時間。
 - ◆ 刀座交換方式以AC馬達處理。

- 尾料壓料機及廢料卷取機**
- ◆ 壓住尾料防止掉入地基中。
 - ◆ 捲取鐵板的廢邊料。

- No.2 渡橋**
- ◆ 備料渡橋引導材料進入下一台機器。

- 張力機**
- ◆ 採用調壓閥控制張力。
 - ◆ 計長輪可計算料捲長度。
 - ◆ 使用可替換的羊毛氈，保護材料表面。
 - ◆ 選購：皮帶式

- 後段剪床 (選購)**
- ◆ 當母材需要分割成大小不同的料卷時使用。

- 回卷機**
- ◆ 將分條後的材料收成料卷。
 - ◆ 選購：無縫式回收料架。
 - ◆ 選購：內徑有 ϕ 508 mm 或 ϕ 610 mm。

- 收卷台車**
- ◆ 從料架移出料卷。

- 十字旋轉座**
- ◆ 暫存在旋轉座上，節省搬運時間。

Automatic Packing Machine

自動打包設備

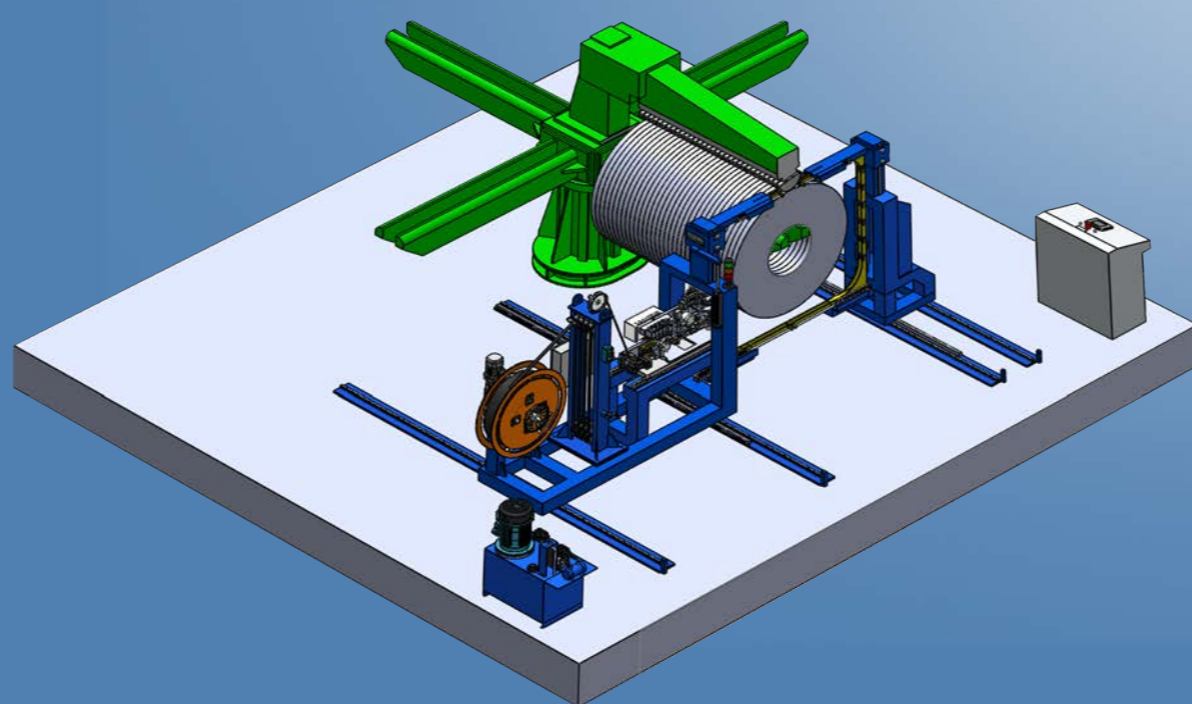

Shung Dar® Automation Steel Slitting Line
COIL HANDLING EQUIPMENT

自動化鋼卷分條線

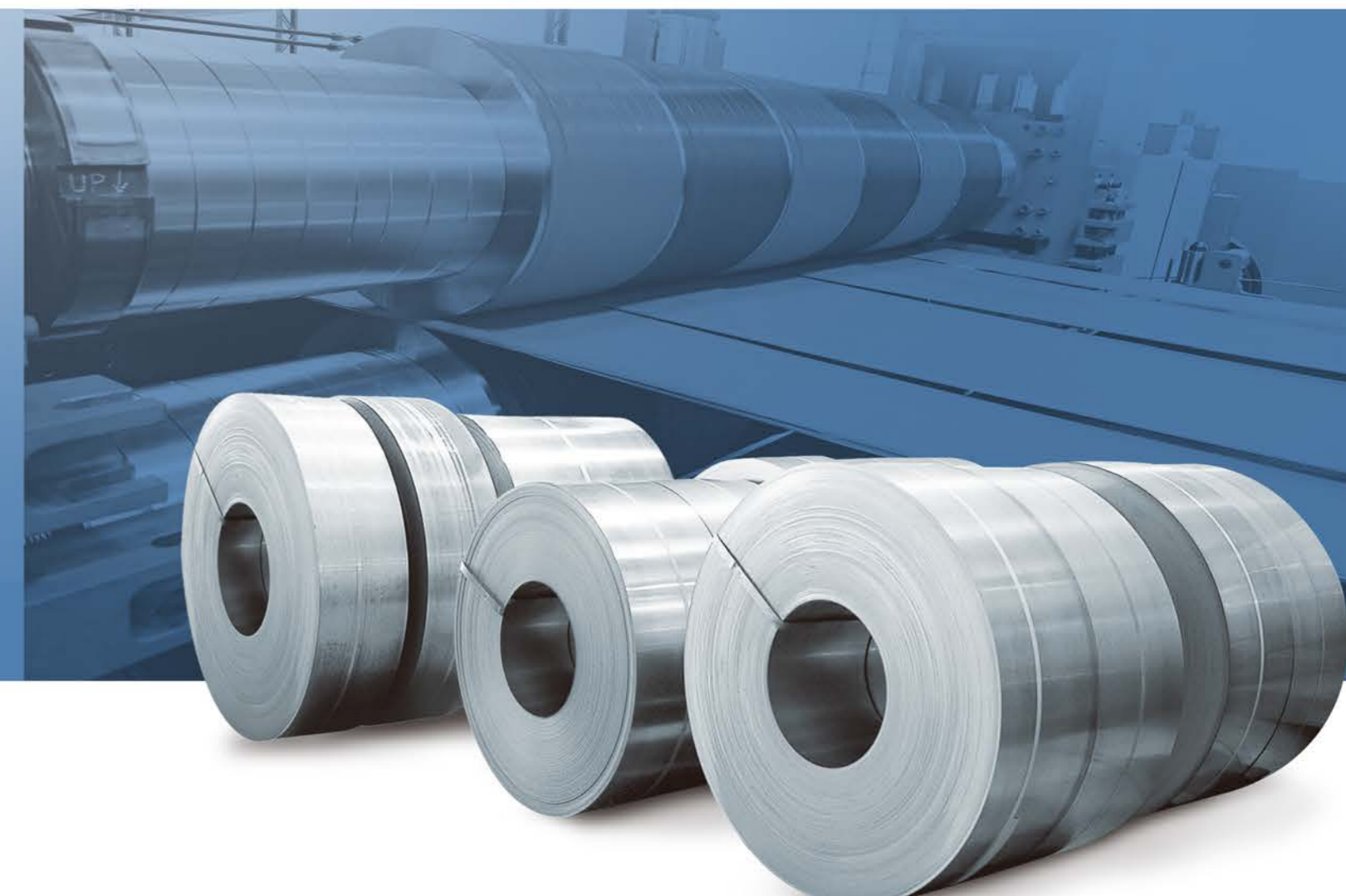

SHUNG DAR INDUSTRIAL CO., LTD.
順達實業股份有限公司

台灣 500 彰化市線東路一段 274-16 號
No. 274-16, Sec. 1, Hsien Tung Rd.,
Changhua City 500, Taiwan
TEL: +886-4-762-2020
FAX: +886-4-762-2022
E-mail: shungdar@ms17.hinet.net
Http://www.shungdar.com



KUNSHAN SOONDAR MACHINERY CO., LTD.
昆山順達機械有限公司

江蘇省昆山市城北利爾路 188 號
188, Lier Rd., Kunshan City, Jiangsu. China.
TEL: 0512-5775-0961 (per.)
FAX: 0512-5775-0963
東莞服務處
TEL: 136-0391 4150
FAX: 0769-7295229
E-mail: soondar@vip.163.com

02.2016 / 1100 03.03.15 Survey 04.2022 7907



www.shungdar.com.tw

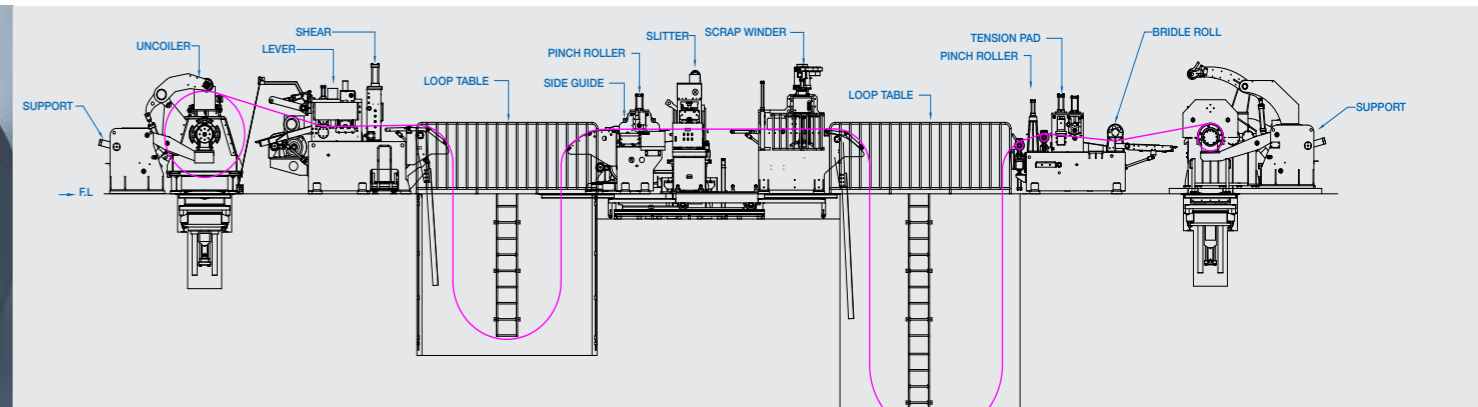
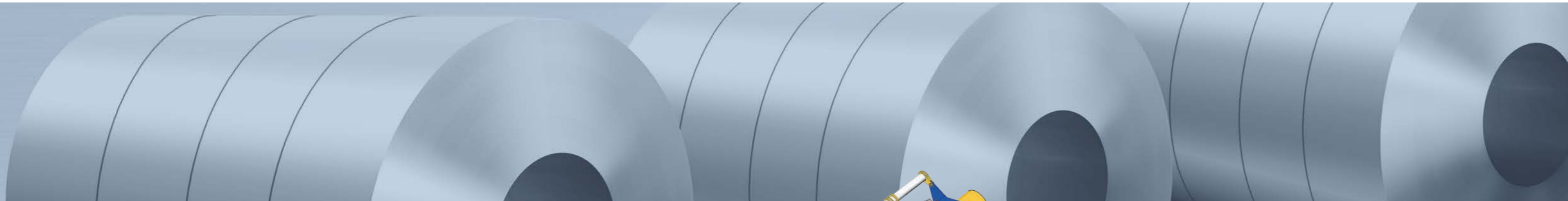

Automation Steel Slitting line

The experience acquired in over 35 years of developing automation production facilities makes SHUNGDAR a solid reference point today in the sector for steel processing industry.

SHUNGDAR provides customized slitting line solutions for all dimensions, from hot-rolled steel, cold-rolled steel to stainless steel, from steel thickness 0.3mm to 12.0mm, from steel width 1220mm to 2000mm.

Advanced and pioneering technology of mechanical design are cooperated to meet the customers' requirements.

Thanks to the design of dual slitter system, changeover time is shortened, and productivity doubled. Double seats enable offline blade arrangement while the production line running. It is the key for saving time of production.

With rotating four-arm turnstile device, slit strips can be temporarily stored on the heavy-duty turnstile arm to allow off-mandrel strapping, and allow operators to select any coil in any order. Greater convenience and efficiency are enhanced owing to the design of this equipment.

SHUNGDAR is known for its reliability of products, and acts as a leader in the field of Taiwan. Focus on the strength of mechanical structure; abrasion resistant and long lifespan.

SHUNGDAR's target is to purpose its customers, whether local or overseas, with technical solutions specific to their needs and goals.

自動化鋼卷分條線

超過35年的自動化生產設備開發經驗，使順達機械成為當今鋼鐵加工製造業的參考指標。

順達機械提供客製化的設計，適用於各種料卷材質，從熱軋鋼，冷軋鋼到不銹鋼，厚度範圍從0.3mm到12.0mm，寬度範圍從1220mm到2000mm，可滿足廣大客戶的需求。

選用雙刀座系統的設計，可在生產線運行時實現離線排刀作業，縮短生產時間，提高生產效率。

通過十字旋轉臂的裝置，可將分條後的子料卷存放在旋轉臂上，方便操作人員捆紮打包，由於該設備的設計，提高了便利性和效率性。

順達機械作為台灣業界的領導先驅，以產品的可靠性而聞名，不僅注重機械結構的強度及耐磨性，也注重機械壽命。

順達機械的目標是針對客戶的需求提供技術性的解決方案。



1 Entry Coil Car / Supporting Arm / Uncoiler
上卷台車/支撐臂/開卷機



2 Threading & Straightener
入料機構+矯正機



3 Shear Unit
裁切機



4 Scrap Collector
廢料小車



5 No.1 Loop Table
No.1 渡橋



6 Pinch Roller
進料輪



7 Single Slitter Seat
分條機



8 Double Slitter Units
雙座式分條機



9 Coil End Holder & Scrap Rewinder
尾料壓料及廢料卷取機



10 No.2 Loop Table
No.2 渡橋

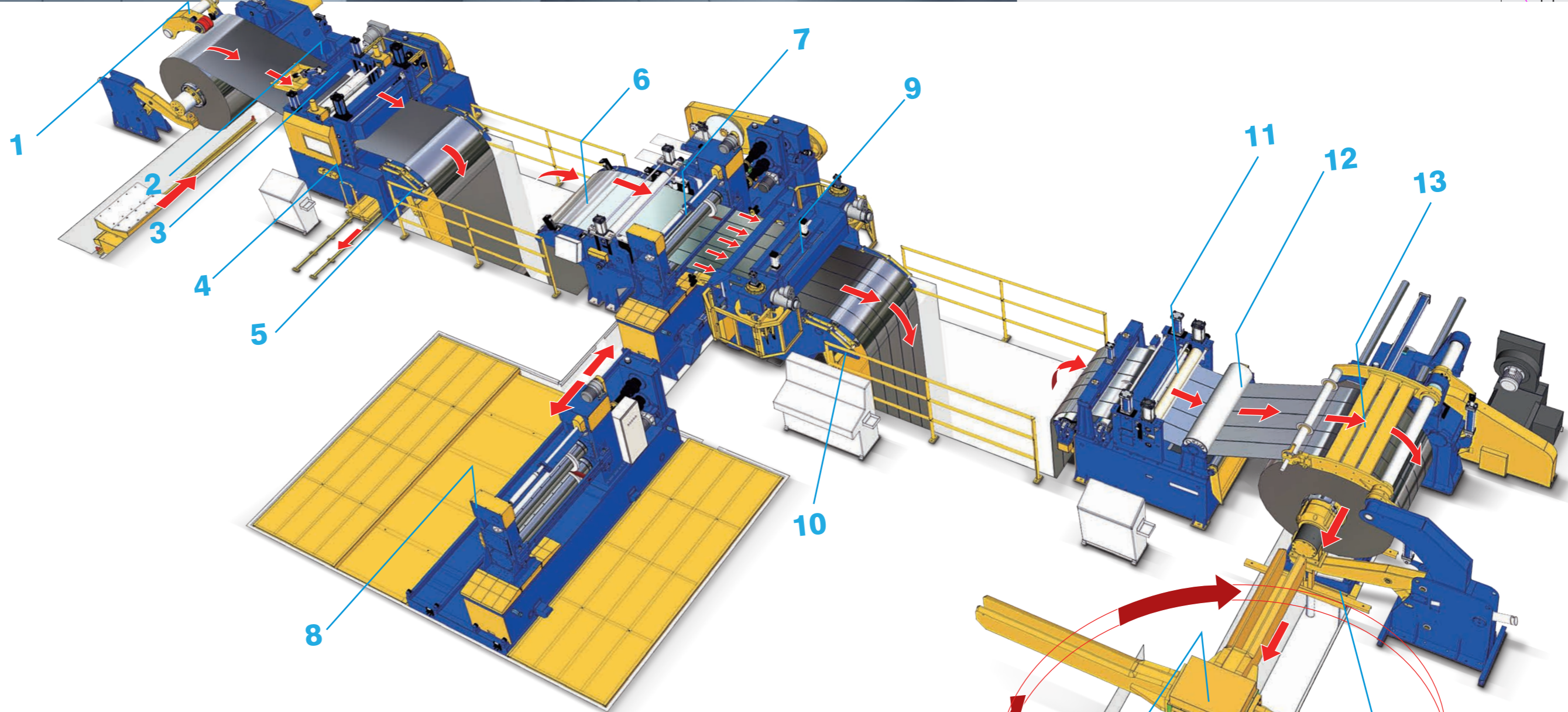

11 Tension Unit
張力機



12 Tension Roll
張力輪



13 Recoiler
收卷機



14 Exit Coil Car
收卷台車



15 Turnstile
十字旋轉座

