

CNC PRECISION VECTOR VISE

Model: HVV-4", 6", 8"

PATENTED
M278511
M338717

- Super-Big Jaw Opening
- **Special ANGLE-LOCK SYSTEM** ensures to pull the work-piece down to the accurate position
- **Fixed Height**, so several vises can be used together

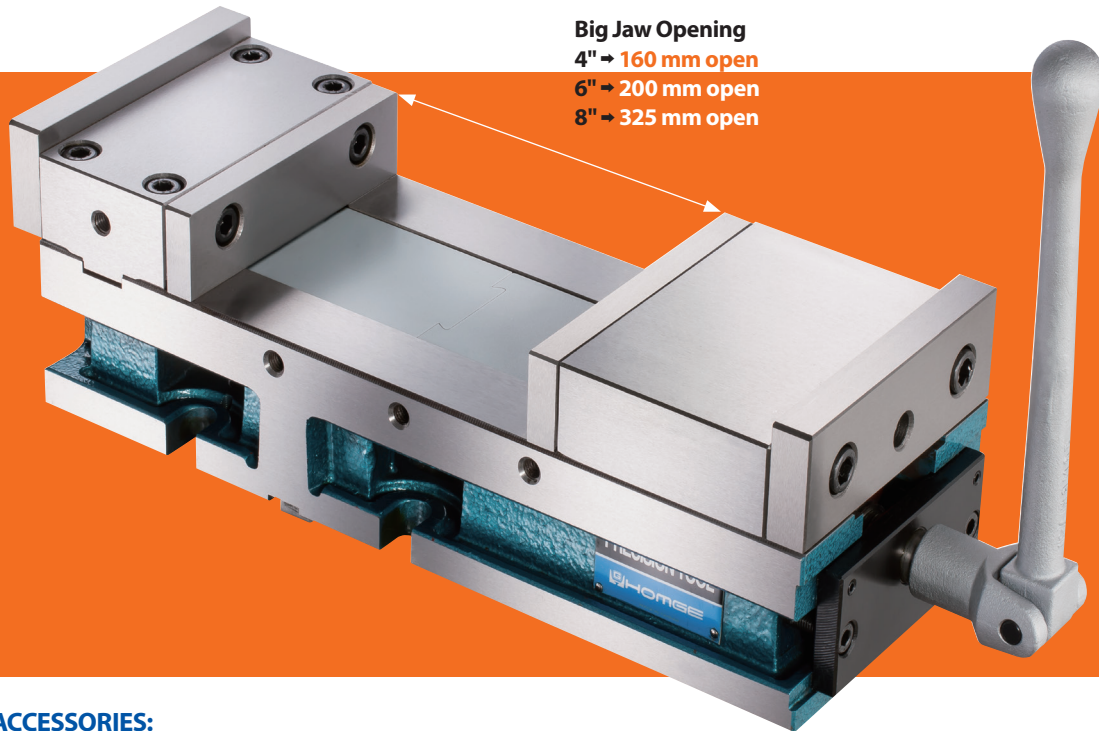

STANDARD ACCESSORIES:

- 1 Set of Front/Back Jaws
- 4 pcs of Clamp

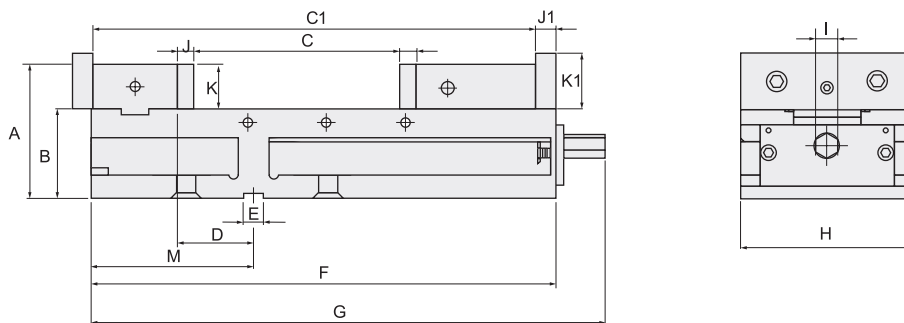

SPECIFICATIONS (Material: FCD 60 Ductile Iron. Hardness: HRC 50°)

Unit: mm

MODEL	A	B	C	C1	D	E	F	G	H
HVV-4"	91	62±0.01	160	320	73±0.02	18	325	365	105
HVV-6"	120	80±0.01	200	410	68±0.02	18	419	468	154
HVV-8"	136	84±0.01	325	550	76±0.02	18	556	612	202
MODEL	I	J	J1	K	K1	M	Weight (kg)		
HVV-4"	14	15	18	28.5	37	120±0.02	18		
HVV-6"	19	15	18	39.5	50	143±0.02	37		
HVV-8"	19	18	21	51.5	60	168±0.02	60		