

3DC-TOOLS



建緯精密科技股份有限公司
CHIEN WEI PRECISE TECHNOLOGY CO.,LTD.



規格 SPECIFICATION	3DC-TOOLS
量測範圍 MEASURING RANGE	150 x 100 x 200 mm(X,Y,Z)
解析讀數 RESOLUTION	SCALES 0.0005mm in 3 Axes
量測軟體 SOFTWARE	MSU-3D PRO
電腦硬體 HARDWARE	PC + 24" Monitor + WIN-PRO
取像系統 VISION	Color CCD + Zoom
放大倍率 ZOOM	30X ~ 200X
投射燈源 ILLUMINATION	WHITE LED LIGHT
刀架旋轉台 TURRET	ROTARY TABLE WITH 120 GONIOMETER
傳動方式 TRANSMISSION	Linear Guideway + Rolling Drive Nut 無牙螺桿 + 線性滑軌
操作方式 OPERATION	Manual 手動
外型尺寸 DIMENSION	130 x 60 x 85 cm (Including PC)
機器重量 MACHINE WEIGHT	180 kgs
選購配備 OPTION	COAXIAL ILLUMINATION 同軸光
選購配備 OPTION	V 形枕 V-BLOCK



建緯精密科技股份有限公司
CHIEN WEI PRECISE TECHNOLOGY CO., LTD.

台灣高雄總公司地址：高雄市鳳山區 83041 鎮北里鎮北北巷 20-16 號
HEADQUARTERS: No. 20-16, Chen Pei N. Lane,
Fengshan District, Kaohsiung City 83041, Taiwan.
TEL: 886-7-7313911 FAX: 886-7-7314976
E-Mail: info@chienwei.com.tw http://www.chienwei.com/
桃園辦事處：334 桃園市八德區豐田七街 35 號
電話：886-3-3681739；傳真：886-3-3680094
E-MAIL:taoyuan@chienwei.com.tw
台中辦事處：406 台中市北屯區軍福 18 路 13 號
電話：886-4-2436-6250；傳真：886-4-2439-2589
E-MAIL:taichung@chienwei.com.tw
昆山長豐精密儀器有限公司
KUNSHAN CHANGFENG PRECISE INSTRUMENTS CO., LTD.
江蘇省昆山市張浦鎮大市大中山路 12 號
TEL: 86-512-57258001 FAX: 86-512-57258006
E-Mail: kschangfeng@163.com



※本公司保留對此型錄做修改之權利，修改時恕不另行通知。(2021-10)
※Chien Wei reserves the right to change specifications without notice.

A High Accurate CMM Can Help
Your Measuring Succeed
二次元座標量測儀

2 Dimensions Coordinate
Measuring Machine

目次 CONTENTS

P.2 2D 影像量測儀選購配備圖示

P.3 二次元座標量測儀特性介紹

P.4 MSU 3D Pro 簡介

P.5 MX-200 MPD-N 簡介

P.7 CW-1510N-PC

P.8 CW-3030-PC

P.9 CW-2020N-PC

P.10 CW-2020N-CNC

P.11 CW-3020-PV-CNC

P.11 TJG-3030DV-CNC

P.12 PJG-450DV-CNC

P.13 TJG-6060DV-CNC

P.14 TJG-7080DV-CNC

P.15 3DC-TOOLS



2D 影像量測儀選購配備圖示 Photos of optional accessories

配備 EQUIPMENT

Auto Zoom



MX-200 DRO Counter



Renishaw PROBE WITH STAR STYL



轉盤 ROTARY TABLE

CW-1510N 轉盤



CW-2020N 轉盤



CW-3030 轉盤



夾持治具 CLAMPING JIG TOOL

V型旋轉治具 V-type rotary tool
夾持工件範圍 Workpiece dia:
Ø3.0mm ~ Ø40.0mm



高精度圓型夾具 Round type ER 32
夾持工件範圍 Workpiece dia:
Ø2.0mm ~ Ø20.0mm 可換筒夾



圓型夾持治具 Round type
夾持工件範圍 Workpiece dia:
標準 Ø3.0mm ~ Ø15.0mm
特殊 Ø15.0mm ~ Ø25.0mm



CHIEN WEI PRECISION TECHNOLOGY CO., LTD.
18, Chen Pei N. Lane, Chen Pei Li,
Keelung Dist 830, Keelung City, Taiwan.
TEL: 886-7-313811 FAX: 886-7-314978
臺南市鳳山區湖北里湖北巷20-16號

1. 特色

可依量測工件之種類不同，自行選擇顯微鏡、CCD 照相機、雷射等各式取像系統來搭配使用。更能依個人之不同應用需求，而作手動、搖桿 / 馬達驅動，或是 CNC 全自動等三種不同選擇之操作方式。

2. 適用對象

IC 零件電子業、半導體相關之 LEAD FRAME 等製造業、P.C.B 板業、熱壓板、LCD 背光板底片、網板印刷、線切割、放電加工、橡膠業、精密模具業、精密之 2D 機械零件加工業 ... 等。

3. 量測功能

選用多功能計數顯示器 MSU 3DPRO 或電腦量測軟體可作點、線、圓、弧、距離、夾角、極座標轉換、節距增量值等之計算，以及工件基準邊之擺正、量測數值之儲存記憶、精度補償、RS232 連線列印輸出等完整功能。

I. Features :

Options of Centering Microscope, CCD Camera, Laser and other projection system depends on the different workpiece. Further application, manual, motorized with joystick or the CNC model can be optional by your demands.

2.Application :

IC electronics, Lead Frame and the related manufacturers in the fields of LCD, Semiconductor, P.C.B. Screen Printing WireCut, E.D.M, Rubber, Plastic, Precise Mold & Dies and other 2D workpiece machining.

3. Measuring Functions :

The multi-function MSU 3DPRO effects the 2D geometric measurement of Point, Line, Circle, Arc, Angle, Distance, Pitching, Alignment, and is accompanied with the RS232 port.

提供多種快捷圖標按鈕，快速且容易量測，可在工具列上自行將常用的圖標按鈕組合為一視窗作為專案，並於編程中顯示。

Multi-icon buttons provide a quick and easy measurement. User be able to combine icons with window need in tool bar as project and display in program.

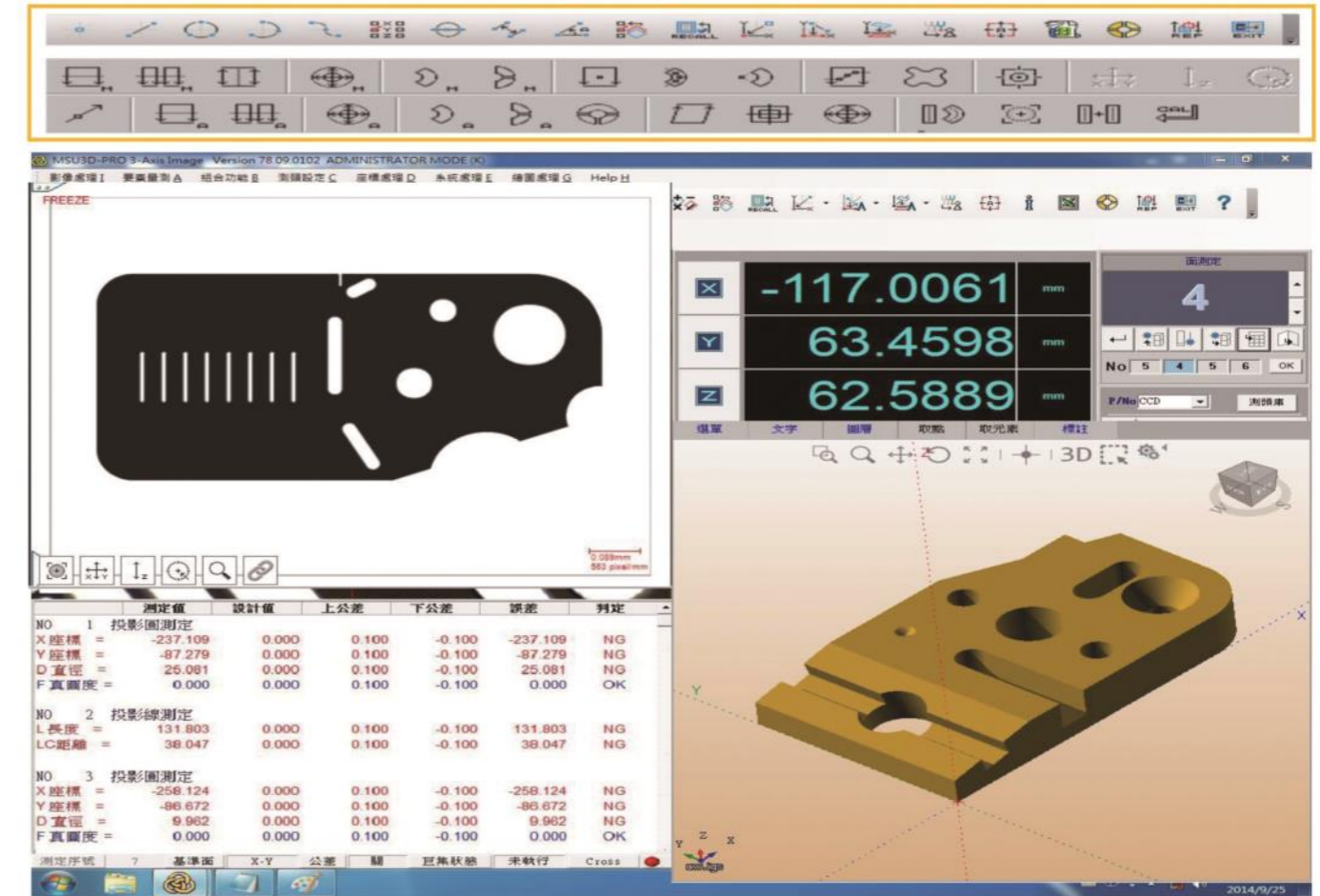

自動對焦功能-CNC: Auto-focus:

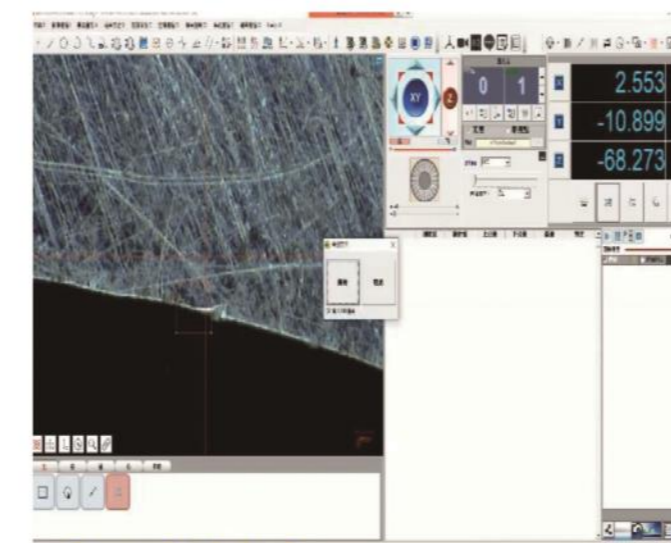

支援偏差曲線功能: Profile deviation:

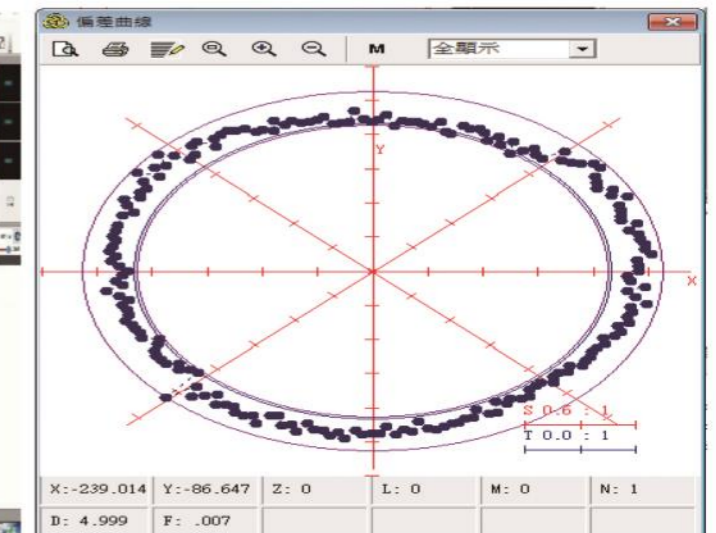

MX-200



- Mx200 是一種用於執行兩軸和三軸測量的計量讀數器。
- 使用光學比較器、測量顯微鏡和各種其他十字線測量。
- 通過觸碰屏幕或通過使用實體鍵盤和功能鍵進行操作。

MX200 is DRO counter of 2D/3D measurement.
 Ideal for Optical Comparators, Measuring Microscopes, or any Metrology device requiring encoder supported measurement.
 Supporting Keypad and Touchscreen control.

MPD-N



- 採用多點觸控彩色螢幕 操作方便 Multiple points click on touch panel.
- 和機台無線連接 配線簡潔 Bluetooth connection simple and easier.
- 提供文字及圖形顯示結果 measurement result by Graphics and text display.
- 完整量測功能 擺正座標 Completed function set with Alignment

量測刀具功能：

Tools measurement:

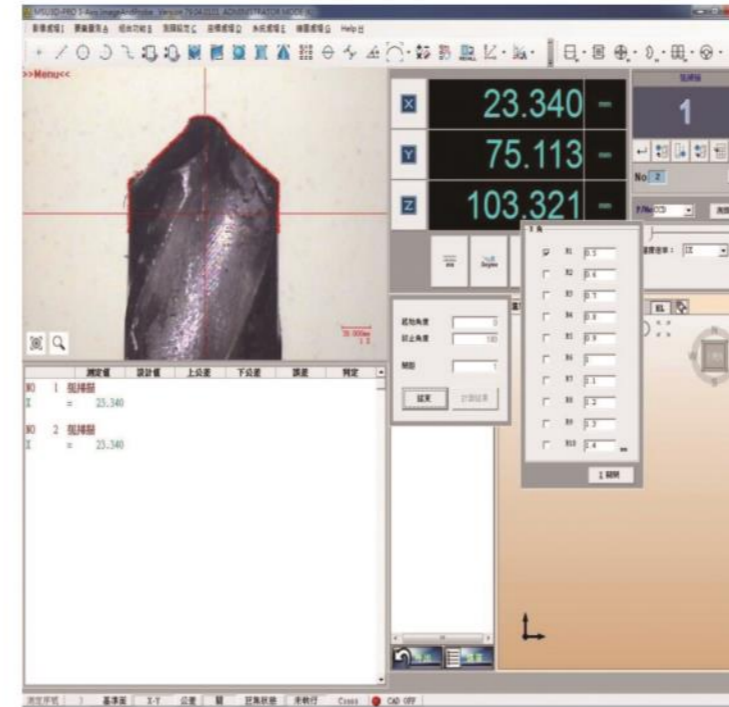

網版工件影像線量測：

Image measuring for screen print:

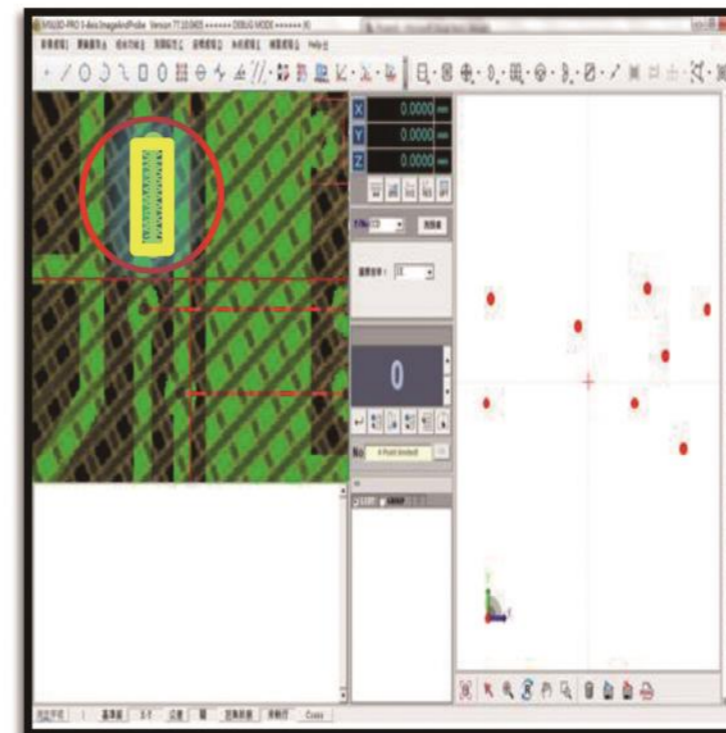

自動對位功能：

Auto-Alignment:

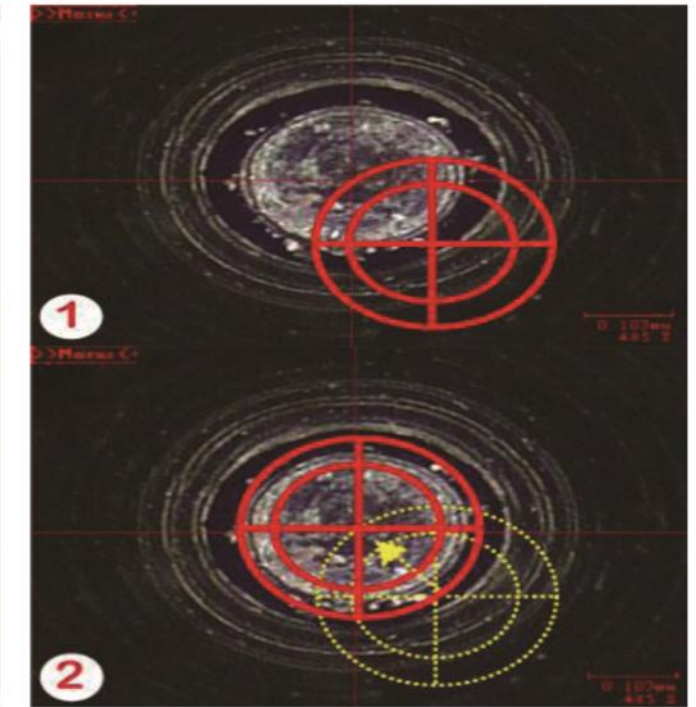

提供公差判定功能：

Tolerance check

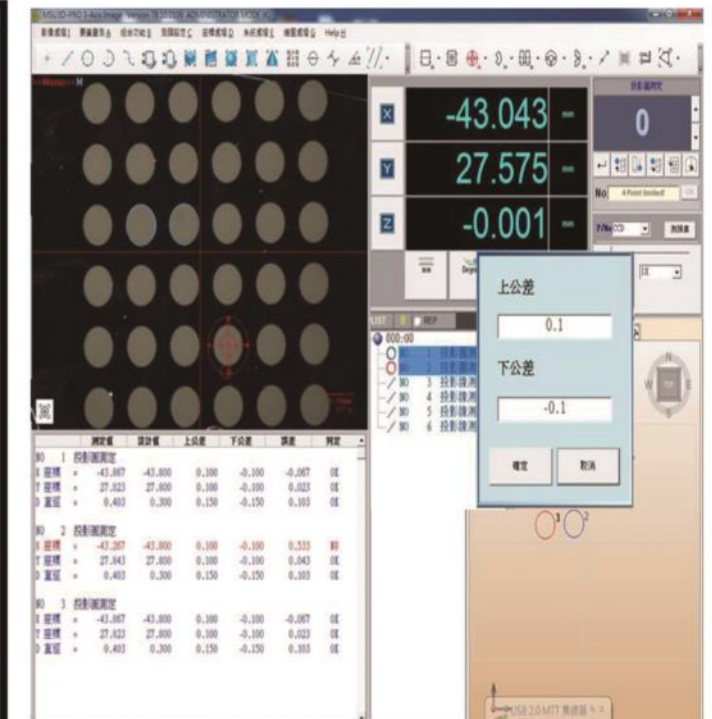

CW-1510



MX-200



規格 SPECIFICATION	CW-1510N	CW-1510N-PC
量測範圍 MEASURING RANGE	150 x 100 x 160 mm(X,Y,Z)	150 x 100 x 160 mm(X,Y,Z)
解析讀數 RESOLUTION	Scales 0.0005mm in 2 Axes (二軸)	Scales 0.0005mm in 2 Axes (二軸)
顯示器 COUNTER / DRO	MX-200 or MPD-N	
影像系統 VISION	CCD + Zoom + 24" Monitor + Cross-Hair (built-in)	CCD + Zoom
放大倍率 ZOOM	30X ~ 200X	30X ~ 200X
表面燈源 SURFACE LIGHT	White LED Light	White LED Light
輪廓底光 CONTOUR LIGHT	Green LED	Green LED
量測精度 ACCURACY	U1= 3 + L/200 um	U1= 3 + L/200 um
重複精度 REPEATABILITY	0.002 mm	0.002 mm
傳動方式 TRANSMISSION	Linear Guideway + Rolling Drive Nut 無牙螺桿 + 線性滑軌	Linear Guideway + Rolling Drive Nut 無牙螺桿 + 線性滑軌
操作方式 OPERATION	Manual 手動	Manual 手動
工件限高 DEMO-PARTS HEIGHT	100 mm	100 mm
工作限重 DEMO-PARTS WEIGHT	5 kgs	5 kgs
外型尺寸 DIMENSION	46 x 50.4 x 88 cm	46 x 50.4 x 88 cm
外型尺寸 - 包括週邊 DIMENSION	136 x 50.4 x 88 cm (with Cabinet)	150 x 50.4 x 88 cm (With PC)
機器重量 MACHINE WEIGHT	60 kgs	60 kgs
選購配備 OPTION	Bottom light / coaxial light 聚光底燈 / 同軸光	Bottom light / coaxial light 聚光底燈 / 同軸光
PC 電腦 PC HARDWARE		PC + 24" Monitor + WIN-PRO
量測軟體 MEASURING SOFTWARE		MSU-3D PRO / M3

CW-3030



CW-3030N-PC



規格 SPECIFICATION	CW-3030N	CW-3030N-PC
量測範圍 MEASURING RANGE	300 x 300 x 130 mm(X,Y,Z)	300 x 300 x 130 mm(X,Y,Z)
解析讀數 RESOLUTION	Scales 0.0005mm in 2 Axes (二軸)	Scales 0.0005mm in 2 Axes (二軸)
顯示器 COUNTER / DRO	MX-200 or MPD-N	
影像系統 VISION	CCD + Zoom + 24" Monitor + Cross-Hair (built-in)	CCD + Zoom
放大倍率 ZOOM	30X ~ 200X	30X ~ 200X
表面燈源 SURFACE LIGHT	White LED Light	White LED Light
輪廓底光 CONTOUR LIGHT	Green LED	Green LED
量測精度 ACCURACY	U1= 3 + L/200 um	U1= 3 + L/200 um
重複精度 REPEATABILITY	0.002 mm	0.002 mm
傳動方式 TRANSMISSION	Linear Guideway + Rolling Drive Nut 無牙螺桿 + 線性滑軌	Linear Guideway + Rolling Drive Nut 無牙螺桿 + 線性滑軌
操作方式 OPERATION	Manual 手動	Manual 手動
工件限高 DEMO-PARTS HEIGHT	120 mm	120 mm
工作限重 DEMO-PARTS WEIGHT	10 kgs	10 kgs
外型尺寸 DIMENSION	83 x 102 x 95 cm	83 x 102 x 95 cm
外型尺寸 - 包括週邊 DIMENSION	173 x 102 x 95 cm (with Cabinet)	173 x 102 x 95 cm (With PC)
機器重量 MACHINE WEIGHT	150 kgs	150 kgs
選購配備 OPTION	Bottom light / coaxial light 聚光底燈 / 同軸光	Bottom light / coaxial light 聚光底燈 / 同軸光
PC 電腦 PC HARDWARE		PC + 24" Monitor + WIN-PRO
量測軟體 MEASURING SOFTWARE		MSU-3D PRO / M3

CW-2020N



CW-2020N-PC

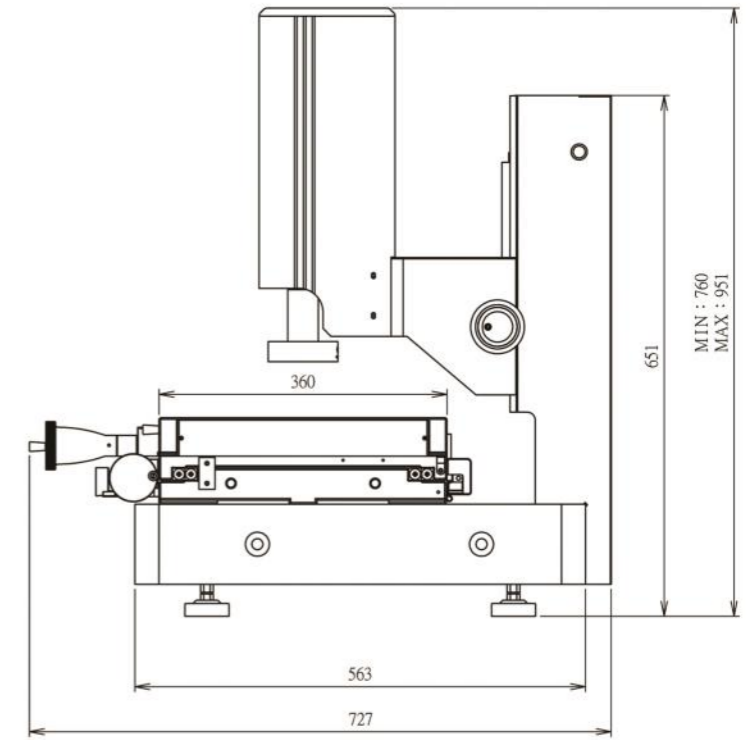
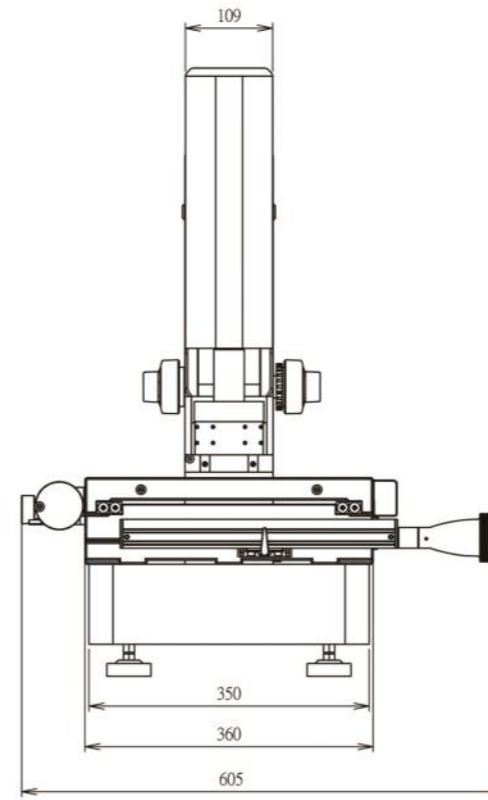

規格 SPECIFICATION	CW-2020N	CW-2020N-PC	CW-2020N-CNC
量測範圍 MEASURING RANGE	200 x 200 x 180 mm(X,Y,Z)	200 x 200 x 180 mm(X,Y,Z)	200 x 200 x 180 mm(X,Y,Z)
解析讀數 RESOLUTION	Scales 0.0005mm in 2 Axes (二軸)	Scales 0.0005mm in 2 Axes (二軸)	Scales 0.0005mm in 3 Axes (三軸)
顯示器 COUNTER / DRO	MX-200 or MPD-N		
影像系統 VISION	CCD + Zoom + 24" Monitor + Cross-Hair (built-in)	CCD + Zoom	CCD + Zoom
放大倍率 ZOOM	30X ~ 200X	30X ~ 200X	30X ~ 200X
表面燈源 SURFACE LIGHT	White LED Light	White LED Light	White LED Light
輪廓底光 CONTOUR LIGHT	Green LED	Green LED	Green LED
量測精度 ACCURACY	U1= 3 + L/200 um	U1= 3 + L/200 um	U1= 3 + L/200 um
重複精度 REPEATABILITY	0.002 mm	0.002 mm	0.002 mm
傳動方式 TRANSMISSION	Linear Guideway + Rolling Drive Nut 無牙螺桿 + 線性滑軌	Linear Guideway + Rolling Drive Nut 無牙螺桿 + 線性滑軌	Linear Guideway + Rolling Drive Nut 無牙螺桿 + 線性滑軌
操作方式 OPERATION	Manual 手動	Manual 手動	CNC Program 程式控制
工件限高 DEMO-PARTS HEIGHT	150 mm	150 mm	150mm
工作限重 DEMO-PARTS WEIGHT	10 kgs	10 kgs	10 kgs
外型尺寸 DIMENSION	60.5 x 72.7 x 95 cm	60.5 x 72.7 x 95 cm	55 x 63.4 x 95 cm
外型尺寸 - 包括週邊 DIMENSION	150 x 72.7 x 95 cm (with Cabinet)	90.5 x 72.7 x 95 cm (With PC)	145 x 63.4 x 95 cm (With PC)
機器重量 MACHINE WEIGHT	133 kgs	133 kgs	105 kgs
選購配備 OPTION	Bottom light / coaxial light 聚光底燈 / 同軸光	Bottom light / coaxial light 聚光底燈 / 同軸光	Bottom light / coaxial light 聚光底燈 / 同軸光
PC 電腦 PC HARDWARE		PC + 24" Monitor + WIN-PRO	PC + 24" Monitor + WIN-PRO
量測軟體 MEASURING SOFTWARE		MSU-3D PRO / M3	MSU-3D PRO / M3

CW-2020N-CNC



CW-3020



TJG-3030



PJG-450



規格 SPECIFICATION	CW-3020PV-CNC	TJG-3030DV-CNC	規格 SPECIFICATION	PJG-450DV-PC	PJG-450DV-CNC
量測範圍 MEASURING RANGE	300 x 200 x 100 mm(X,Y,Z)	300 x 300 x 200 mm(X,Y,Z)	量測範圍 MEASURING RANGE	430 x 420 x 200 mm(X,Y,Z)	430 x 420 x 200 mm(X,Y,Z)
解析讀數 RESOLUTION	0.001 mm Scales	0.0005mm in 3 Axes (三軸)	解析讀數 RESOLUTION	0.001mm in 2 Axes (二軸)	0.001mm in 3 Axes (三軸)
量測軟體 SOFTWARE	MSU-3D PRO	MSU-3D PRO	量測軟體 SOFTWARE	MSU-3D PRO	MSU-3D PRO
影像系統 VISION	Color CCD + Zoom	Color CCD + Zoom	影像系統 VISION	Color CCD + Zoom	Color CCD + Zoom
放大倍率 ZOOM	30X ~ 200X	30X ~ 200X	放大倍率 ZOOM	30X ~ 200X	30X ~ 200X
表面燈源 SURFACE LIGHT	White LED	White LED	表面燈源 SURFACE LIGHT	White LED	White LED
輪廓底光 CONTOUR LIGHT	Green LED	Green LED	輪廓底光 CONTOUR LIGHT	Green LED	Green LED
量測精度 ACCURACY	U1= 2 + L/200 um	U1= 3 + L/200 um ; U2= 5 + L/150 um	量測精度 ACCURACY	U1= 4 + L/200 um ; U2= 6 + L/150 um	U1= 4 + L/200 um ; U2= 6 + L/150 um
單點重複精度 REPEATABILITY	0.002 um	0.002 mm	單點重複精度 REPEATABILITY	0.003 mm	0.003 mm
傳動方式 TRANSMISSION	Linear Guideway + Rolling Drive Nut 無牙螺桿 + 線性滑軌	Linear Guideway + Rolling Drive Nut 無牙螺桿 + 線性滑軌	傳動方式 TRANSMISSION	Linear Guideway + Rolling Drive Nut 無牙螺桿 + 線性滑軌	Linear Guideway + Rolling Drive Nut 無牙螺桿 + 線性滑軌
操作方式 OPERATION	CNC Programmable 程序控制	CNC Programmable 程序控制	操作方式 OPERATION	Manual 手動 / Bridge Type	CNC Programmable 程序控制
驅動方式 DRIVE	Servo Motors + Joystick	Servo Motors + Joystick	驅動方式 DRIVE		Servo Motors + Joystick
鑄鐵平臺 CAST IRON			花崗石平臺 GRANITE TABLE	DIN. 876, 0 GRADE (Glass 485 x 485 mm)	DIN. 876, 0 GRADE (Glass 485 x 485 mm)
工件限高 DEMO-PARTS HEIGHT	140 mm Max.	200 mm	工件限高 DEMO-PARTS HEIGHT	100 mm	100 mm
工作限重 DEMO-PARTS WEIGHT	12 kgs Max.	12 kgs	工作限重 DEMO-PARTS WEIGHT	20 kgs	20 kgs
外型尺寸 DIMENSION	890 x 820 x 1090 mm (Including Base Stand)	770 x 1000 x 930 mm	外型尺寸 DIMENSION	110 x 100 x 195 cm (Including Base Stand)	110 x 100 x 195 cm (Including Base Stand)
外型尺寸 - 包括週邊 DIMENSION	1300 x 950 x 1850 mm (Including Deluxe Table)	1400 x 1000 x 930 mm (Including Deluxe Table)	外型尺寸 - 包括週邊 DIMENSION	190 x 100 x 195 cm (Including Deluxe Table)	190 x 100 x 195 cm (Including Deluxe Table)
機器重量 MACHINE WEIGHT	382 kgs	360 kgs	機器重量 MACHINE WEIGHT	550 kgs	580 kgs
電腦硬體 HARDWARE	PC + 24" Monitor + WIN 10-PRO	PC + 24" Monitor + WIN 10-PRO	電腦硬體 HARDWARE	PC + 24" Monitor + WIN 10-PRO	PC + 24" Monitor + WIN 10-PRO
選購配備 OPTION	Programmable Light-Control or Auto-Zoom, Probe, Laser 程式控制調光或倍率調整, 測頭, 雷射, coaxial light 同軸光	coaxial light 同軸光	選購配備 OPTION	MX-200 DRO + 24" Monitor coaxial light 同軸光	Light-Control or Auto-Zoom 程式控制調光或倍率調整 With Renishaw Trigger Probe MCP 簡易式測頭 coaxial light 同軸光

TJG-6060



TJG-6060DV-CNC

TJG-7080



TJG-7080DV-CNC

規格 SPECIFICATION	TJG-6060DV-CNC
量測範圍 MEASURING RANGE	600 x 600 x 200 mm(X,Y,Z)
解析讀數 RESOLUTION	0.0005mm in 3 Axes (三軸)
量測軟體 SOFTWARE	MSU-3D PRO
影像系統 VISION	Color CCD + Zoom
放大倍率 ZOOM	30X ~ 200X
表面燈源 SURFACE LIGHT	White LED
輪廓底光 CONTOUR LIGHT	Green LED
量測精度 ACCURACY	U1= 4 + L/200 um ; U2= 6 + L/150 um
單點重複精度 REPEATABILITY	0.003 mm
傳動方式 TRANSMISSION	Linear Guideway + Rolling Drive Nut 無牙螺桿 + 線性滑軌
操作方式 OPERATION	CNC Program 程序控制
驅動方式 DRIVE	Servo Motors + Joystick
花崗石平臺 GRANITE TABLE	DIN. 876, 0 GRADE (Glass 637 x 637 mm 放置面積)
工件限高 DEMO-PARTS HEIGHT	200 mm
工作限重 DEMO-PARTS WEIGHT	30 kgs
外型尺寸 DIMENSION	125 x 165 x 150 cm (Including Base Stand)
外型尺寸 - 包括週邊 DIMENSION	185 x 165 x 150 cm (Including Deluxe Table)
機器重量 MACHINE WEIGHT	1380 kgs
電腦硬體 HARDWARE	PC + 24" Monitor + WIN 10-PRO
選購配備 OPTION	Light-Control or Auto-Zoom 程式控制調光或倍率調整
選購配備 OPTION	coaxial light 同軸光

規格 SPECIFICATION	TJG-7080DV-CNC
量測範圍 MEASURING RANGE	700 x 800 x 200 mm(X,Y,Z)
解析讀數 RESOLUTION	0.0005mm in 3 Axes (三軸)
量測軟體 SOFTWARE	MSU-3D PRO
影像系統 VISION	Color CCD + Zoom
放大倍率 ZOOM	30X ~ 200X
表面燈源 SURFACE LIGHT	White LED
輪廓底光 CONTOUR LIGHT	Green LED
量測精度 ACCURACY	U1= 4 + L/200 um ; U2= 6 + L/150 um
單點重複精度 REPEATABILITY	0.003 mm
傳動方式 TRANSMISSION	Linear Guideway + Rolling Drive Nut 無牙螺桿 + 線性滑軌
操作方式 OPERATION	CNC Program 程序控制
驅動方式 DRIVE	Servo Motors + Joystick
花崗石平臺 GRANITE TABLE	DIN. 876, 0 GRADE (Glass 788 x 838 mm 放置面積)
工件限高 DEMO-PARTS HEIGHT	200 mm
工作限重 DEMO-PARTS WEIGHT	30 kgs
外型尺寸 DIMENSION	135 x 210 x 150 cm (Including Base Stand)
外型尺寸 - 包括週邊 DIMENSION	205 x 210 x 150 cm (Including Deluxe Table)
機器重量 MACHINE WEIGHT	1380 kgs
電腦硬體 HARDWARE	PC + 24" Monitor + WIN 10-PRO
選購配備 OPTION	Light-Control or Auto-Zoom 程式控制調光或倍率調整
選購配備 OPTION	coaxial light 同軸光