

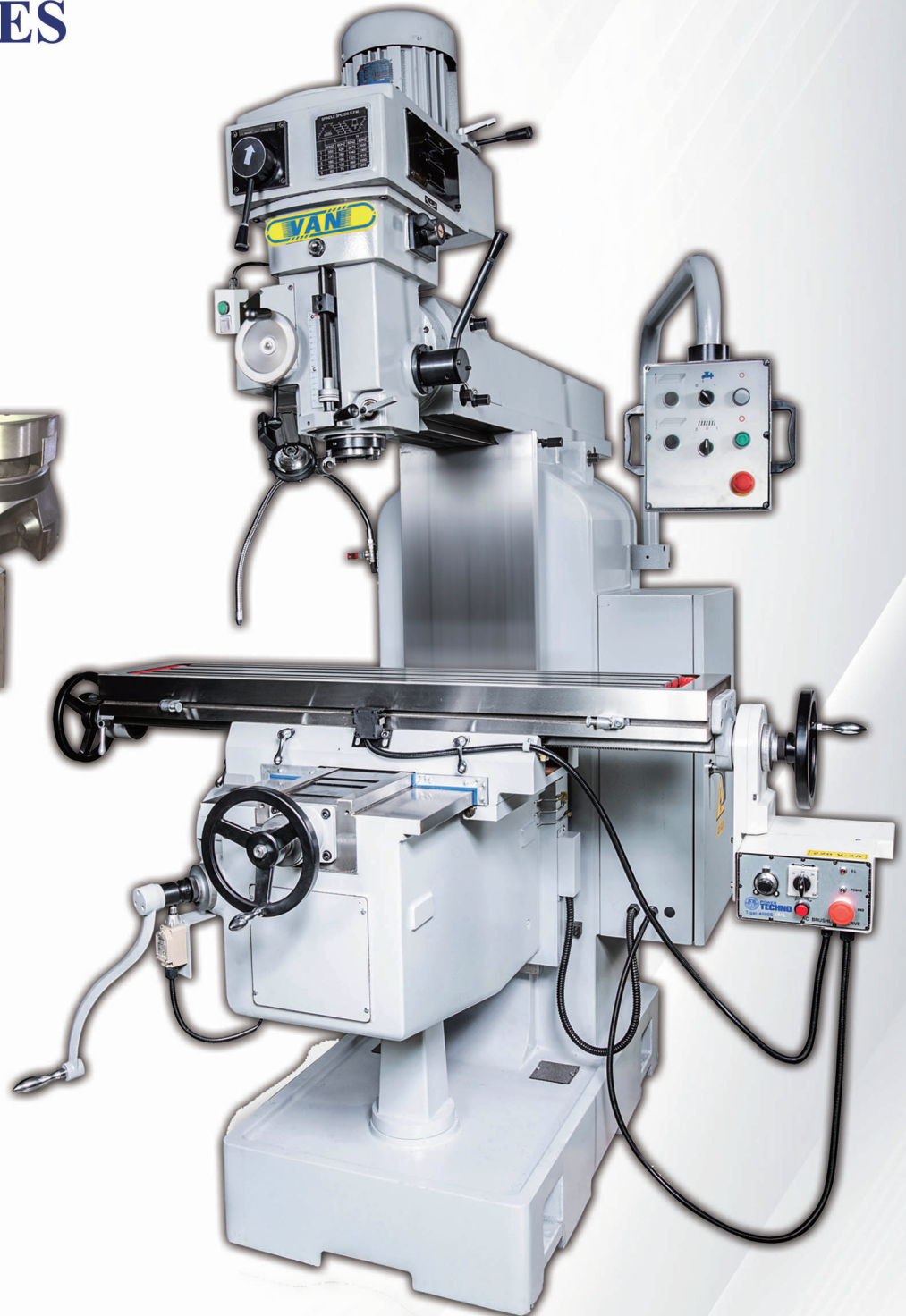

**YING SHUN  
MACHINERY INDUSTRY CO., LTD.**

## **Vertical Turret Milling Machine**

### **YSM-20A SERIES**



## MECHANICAL FEATURE

- The main casting part is made of meehanite casting.
- Milling head type:
  - Steps (S) Inverter (C)
- The spindle is one piece machined from SCM440 alloysteel, high-frequency and precision polishing.
- Hardened and ground X,Y,Z axes slideway.
- Turcite-B coated on X Y ways.



## MECHANICAL DIMENSIONS

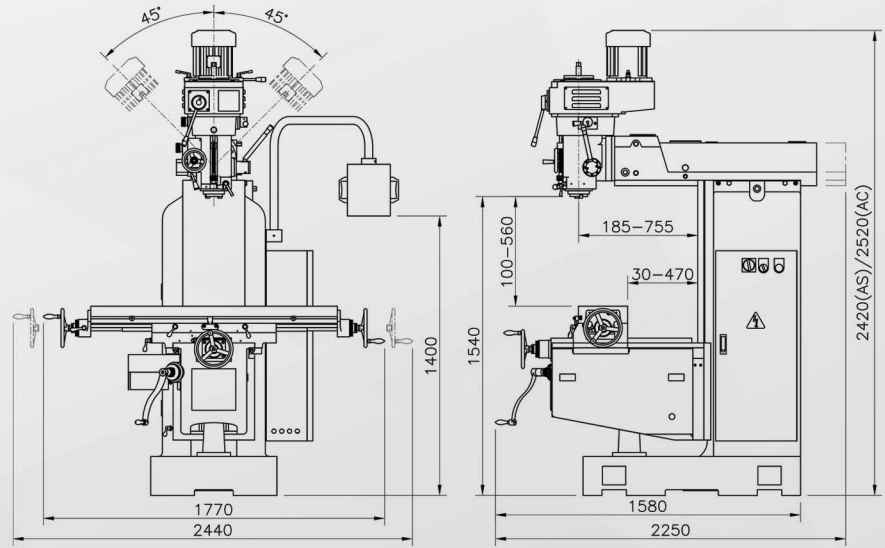

## SPECIFICATONS AND ACCESSORIES

Model	Unit	20AS	20AC
<b>Travel</b>			
Longitudinal travel (M./A.)	mm	750/700(Opt.850/800)	
Cross travel (M./A.)	mm	440	
Vertical travel (M./A.)	mm	460	
Slideway X/Y/Z	type	△ / □ / □	
Quill travel	mm	140	
Overarm travel	mm	570	
Overarm swivel	degree	Fiexd	
Quill swivel (R&L)/(F&B)	degree	±45/Fiexd	
<b>Table</b>			
Dimension	mm	1270x254(Opt.1370x254)	
T-slots (WidthxNo.xPitch)	mm	16x3x63	
<b>Spindle</b>			
Milling head	type	10 Steps	Inverter
Speed	60Hz	rpm	75-3500
	50Hz	rpm	60-2870
Vertical feeds	mm/rev	0.04/0.08/0.15	
Taper	type	NT40	
Quill Diameter	mm	110	
<b>Motor</b>			
Main spindle	HP	5(Opt.7.5)	
Z axis elevation	HP	1	
<b>feedrate</b>			
Z axis speed	mm/min	1150	
<b>Machine</b>			
Net Weight	kg	1750	

### Standard accessories

- Draw bar
- Tool box and tools
- Tapping equipment of spindle
- Chip cover on Y axis
- Working lamp
- Auto lubrication system
- Z Axis Rapid up/down
- Deluxe type operation panel
- Electric box
- Ball scerw (X/Y)

### Optional accessories

- Power drawbar
- Power feed(X/Y)
- Servo feed(X/Y)
- Digital readout ( DRO)
- Coolant system(Pump 1/8HP)
- Chip tray



YING SHUN MACHINERY INDUSTRY CO., LTD.

All specification , dimension and design characteristics shown in this catalogue are subject to change without notice.

No.5,Aly.162,Ln.136,Sec.1,Jiahou Rd.,Houli Dist., Taichung City 421,Taiwan(R.O.C.)

TEL:+886-4-25586346

ys@yingshun.com.tw

FAX:+886-4-25586930

<https://www.yingshun.com.tw>