

ETL

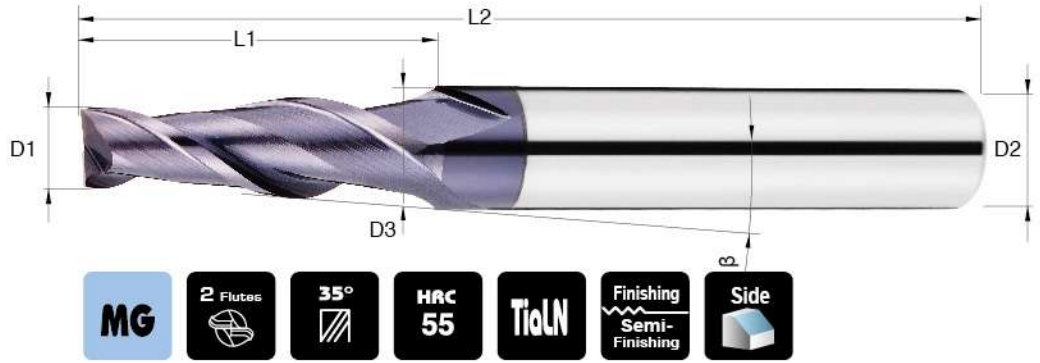

超微粒 長刃斜度立銑刀

▶ Long Flute . Taper / for P K

unit: mm

型號 Order No.	先端徑 Small Mill Dia D1	刃長 Flute Length L1	斜角 Taper Angle β	粗端徑 Large Mill Dia D3	全長 O.A.L. L2	柄徑 Shank Dia D2
ETL 01005	1.0	10	30'	1.17	50	4
ETL 01010	1.0	10	1°	1.35	50	4
ETL 01015	1.0	10	1° 30'	1.52	50	4
ETL 01020	1.0	10	2°	1.70	50	4
ETL 01025	1.0	10	2° 30'	1.87	50	4
ETL 01030	1.0	10	3°	2.05	50	4
ETL 01050	1.0	10	5°	2.74	50	4
ETL 01070	1.0	10	7°	3.44	50	4
ETL 01505	1.5	10	30'	1.67	50	4
ETL 01510	1.5	10	1°	1.87	50	4
ETL 01515	1.5	10	1° 30'	2.02	50	4
ETL 01520	1.5	10	2°	2.20	50	4
ETL 01525	1.5	10	2° 30'	2.37	50	4
ETL 01530	1.5	10	3°	2.55	50	4
ETL 02005	2.0	13	30'	2.22	50	4
ETL 02010	2.0	13	1°	2.45	50	4
ETL 02015	2.0	13	1° 30'	2.68	50	4
ETL 02020	2.0	13	2°	2.90	50	4
ETL 02025	2.0	13	2° 30'	3.13	50	4
ETL 02030	2.0	13	3°	3.36	50	4
ETL 02050	2.0	13	5°	4.27	50	6
ETL 02505	2.5	15	30'	2.76	50	4
ETL 02510	2.5	15	1°	3.03	50	4
ETL 02515	2.5	15	1° 30'	3.29	50	4
ETL 02520	2.5	15	2°	3.56	50	4
ETL 02525	2.5	15	2° 30'	3.81	50	4
ETL 02530	2.5	15	3°	4.07	50	6
ETL 02550	2.5	15	5°	5.13	50	6
ETL 03005	3.0	20	30'	3.35	60	6
ETL 03010	3.0	20	1°	3.70	60	6
ETL 03015	3.0	20	1° 30'	4.05	60	6
ETL 03020	3.0	20	2°	4.39	60	6
ETL 03025	3.0	20	2° 30'	4.65	60	6
ETL 03030	3.0	20	3°	5.10	60	6
ETL 03050	3.0	20	5°	6.50	60	8
ETL 04005	4.0	25	30'	4.44	60	6
ETL 04010	4.0	25	1°	4.88	60	6
ETL 04015	4.0	25	1° 30'	5.13	60	6
ETL 04020	4.0	25	2°	5.75	60	6
ETL 04025	4.0	25	2° 30'	6.19	60	8
ETL 04030	4.0	25	3°	6.62	60	8
ETL 04050	4.0	25	5°	8.38	75	10