

## DGT

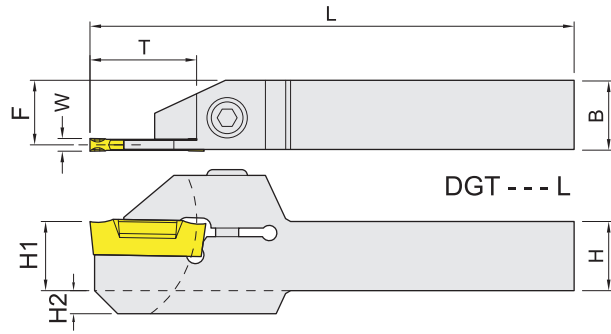
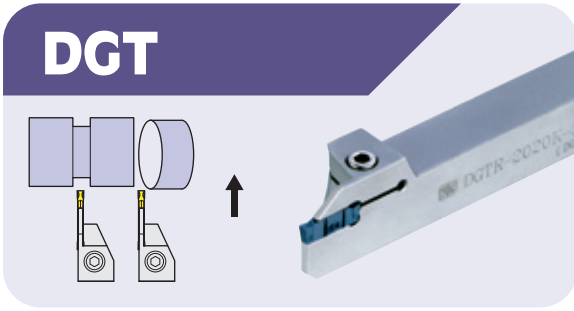

Right-hand shown

Item code	Dimensions,mm						Width W(mm)	Insert	Screw 	Wrench	Weight Kg	
	H(H1)	B	L	F	T	H2						
DGTR/L-1616K-2-13L	16	16	125	15.3	13	--	2.0	DGN20.. DGN22..	HTMT525	ETL25	0.27	
DGTR/L-2020K-2-13L	20	20	125	19.3			2.2				0.42	
DGTR/L-2525M-2-13L	25	25	150	24.3							0.78	
DGTR/L-1212K-2-18L	12	12	125	11.3	18	4		HTM420	PL30		0.14	
DGTR/L-1616K-2-18L	16	16	125	15.3		--		HTMT520		ETL25	0.27	
DGTR/L-2020K-2-18L	20	20	125	19.3				HTMT525			0.42	
DGTR/L-2525M-2-18L	25	25	150	24.3							0.78	
DGTR/L-1616K-3-12L	16	16	125	14.8	12	--	3.0	DGN30..	HTMT520	ETL25	0.27	
DGTR/L-2020K-3-12L	20	20	125	18.8			3.1	DGN31..			HTMT525	0.42
DGTR/L-2525M-3-12L	25	25	150	23.8								0.78
DGTR/L-1616K-3-16L	16	16	125	14.8	16	--			HTMT525		0.27	
DGTR/L-2020K-3-16L	20	20	125	18.8						0.42		
DGTR/L-2525M-3-16L	25	25	150	23.8						0.78		
DGTR/L-1616K-3-20L	16	16	125	14.8	20	4					0.27	
DGTR/L-2020K-3-20L	20	20	125	18.8		--				0.42		
DGTR/L-2525M-3-20L	25	25	150	23.8						0.78		

被切削材 Workpiece material	Steel 鋼	P	●	●	
	Stainless steel 不銹鋼	M	●	●	
	Cast iron 鑄鐵	K			
	Non-ferrous metal 非鐵金屬	N			●

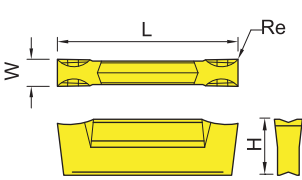
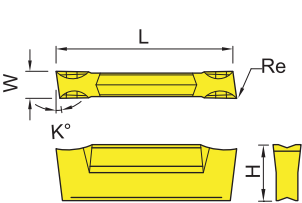
Insert Shape	Description	GRADE 材質			Dimensions,mm			
		Coated 塗層		Uncoated 無塗層	W	L	Re	K°
		IC354	TN6025	IC20				
	DGN 2002C	●		●	2.0	19.7	0.2	--
	2202C	●		●	2.2	19.8	0.2	--
	2202J		●		2.2	19.8	0.2	--
	3102C	●			3.1	20.1	0.2	--
	3102J		●	●	3.1	20.1	0.2	--
	DGR 2202C-6D	●			2.2	19.5	0.2	6
	2202J-6D		●		2.2	19.5	0.2	6
	DGR 3102C-6D	●		●	3.1	20.6	0.2	6
	3102J-6D		●		3.1	20.4	0.2	6
	3102J-15D		●		3.1	20.4	0.2	15