



安全  
Safe

節省成本  
Economical

提升競爭力  
Competitive



## PolarJet CNC Solutions Inc.

台灣台中市北屯區景賢南二路35號  
No.35, Jingxian S. 2nd Rd., Beitun Dist.,  
Taichung City 406, Taiwan

Tel +886-4-24350252  
Fax +886-4-24350253  
info@lisautomatics.com  
www.polarjet.com.tw

### Quality Policy 品質政策

- 創新研發  
Innovation and development
- 品質優先  
Quality priority
- 全員參與  
Total involvement
- 顧客滿意  
Customer satisfaction

### Environmental Policy 環境政策

- 遵守法規  
Regulatory compliance
- 節能減廢  
Energy saving and waste minimization
- 持續改善  
Continuous improvement
- 永續發展  
Sustainable development

## High-Pressure Coolant Systems 高壓切削冷卻系統

# About the Company

## 公司介紹

立石自動控制機器股份有限公司在1979年成立於台灣工具機產業的重要都市-台中市。過去30年，在國內和國際上，立石已是許多工具機製造者油壓單元的獨佔的設計與製造者。我們的產品線已擴展且已變得更加創新來符合一直在進步的金屬切削、壓鑄、和塑膠射出工具機等的需求。在2006年，立石公司成立PolarJet CNC Solutions,Inc. 專門在生產高壓切削系統來幫助國內外的客戶解決難切削材料加工問題。經過這些年的努力，我們已經研發成功一系列的產品提供給不同型態的工具機使用。我們依舊會以客戶優先的立場持續創新，以客戶至上的目標持續邁進，一同與我們的客戶創造雙贏。

LIS Automatic Controlled Co.,LTD. was founded in 1979 in the city of Taichung, the capital of the machine tools industry of Taiwan. For the past thirty years LIS has been the sole designer and manufacturer of the hydraulic units for many machine tools manufacturers, both domestic and international. Our product lines are expanding and become more innovative to meet the demands of ever-improving metal cutting, die casting, and plastic injection tools etc. We are proud to introduce to you our suppliers who we have firm business relationships and commitments for many years; S.A.M.HYCRAULIK S.p.A., HST Hydrospeichertechnik GmbH, ROTOFLUX Srl, etc. Here at LIS, we also produce our own line of valves, pumps, motors, filters, high pressure coolant through spindle systems, hydraulic power pack, etc. We custom design to our customer's industry needs at competitive prices and will guarantee their post installation satisfaction. LIS is also a sourcing agent for your business connection to Taiwan, China and the Pacific Rim.



# Company History

## 公司沿革



- 1979 成立立石自動控制.生產油壓單元系統  
Established LIS Automatics Inc. manufactured hydraulic system
- 1982 開始代理歐洲油壓系統以及零件至台灣  
Introduced European hydraulic system and components to Taiwan
- 2006 開始研發生產高壓系統  
Established PolarJet CNC Solutions Inc. and develop high pressure coolant system
- 2010 第二代PJ系列陸續推出  
Introduced 2<sup>nd</sup> generation PJ series
- 2011 發表PJ-30M  
Introduced PJ-30M
- 2012 發表最新PJ-22ST，同期間宣布興建新廠房以及發開研究室  
Introduced PJ-22ST. Meanwhile, PolarJet CNC Solutions Inc. announced building of a new company facility with research and development laboratory
- 2013 發表多款革命性產品並全系列產品取得TUV CE認證.新廠房落成投入生產  
Introduced a variety of revolutionary products with TUV CE certification and moved to new facility
- 2014 推出140Bar變頻高壓系統  
Introduced variable volume system 140 bar
- 2015 推出100Bar變頻高壓整合冷凍機系統  
Introduced variable volume system 100 bar with oil chiller included
- 2016 持續研發新機種  
Kept developing new PolarJet products
- 2017 發表高壓用消泡裝置及專利高效能低耗材過濾系統  
Introduced anti-foaming device for high-pressure coolant system & PJ-saving system(Patented high-performance & low-cost of material filtration system)
- 2018 發表精巧型高壓系統  
Introduced compact type high-pressure coolant system
- 2019 完成TUV ISO 9001，14001 認證與SGS CE認證. 發表新機種  
Obtained TUV ISO 9001, 14001 certification and SGS CE certification  
Introduced a new series high-pressure coolant system

# The Benefits of High-Pressure Coolant System

## 高壓的好處

- 更好的控制切屑 Chips control efficiency
- 延長刀具壽命 Tool life extension
- 降低加工阻力 Machining resistance reduction
- 更好的表面精度 Improved surface roughness
- 提高生產效率 Improve the production efficiency
- 有效自動化生產 Automated manufacturing efficiency
- 減少人力需求 Manpower requirement reduction

# Why Choose a High-Pressure Coolant System?

## 為何選擇高壓切削液系統？

問題一：當過熱切削時，蒸氣屏障形成

**解決方案** 集中瞄準的高壓切削液可穿透蒸氣屏障，然後順利降低切削時所產生的高溫

問題二：切削液分配不均，會使刀尖無法取得所需的潤滑

**解決方案** 有效地供給切削液，顯著地提高刀具壽命

問題三：在切削刀具潤滑不足的情況下，會導致切屑回到切削點。因此，重覆加工切屑會使刀具壽命縮短及破壞工件表面

**解決方案** 足夠的潤滑改善了工件表面精度，且減少去除毛邊的時間

### Common Problem

Problem1 : Steam forms a vapor barrier when overheating occurs

**Our Solution** Properly aimed, high-pressure coolant penetrates the vapor barrier and eliminates heat.

Problem2 : Poor distribution of coolant prevents proper lubrication from reaching to the cutting tool tip

**Our Solution** Efficient coolant distribution significantly increases tool life.

Problem3 : Insufficient tool lubrication results in chips returning back into tool cutting area. Consequently, repeatedly hitting chips shortens tool life and damages workpiece surface

**Our Solution** Sufficient lubrication improves finished surface and reduces time spent on the deburring process.

# PJ-22V0



## Specifications 基本規格表

	PJ-22V0	
適用液體 Fluid Type	水基切削液、油基切削液 (黏度係數15-32cst) Water base coolant, Oil base coolant (viscosity 15-32cst)	
控制面版 Control Panel	人機介面 HMI Screen	
最大工作壓力 Max working pressure	140 Bar / 2000 PSI	
最大流量 Max flow rate	24 Liter/min	
出水口數量 Number of ports	4 (標準) (Standard)	
過濾精度 Filtration	5μ 單過濾罐 SingleFilter (濾袋式 / Filter Bag)	
額定功率 Rated power	6.51KW	6.52KW
額定負載 Rated load	8.72HP	8.73HP
補水泵 Suction pump	內含 (Included)	
電壓 Voltage	200V、220V、380V、400V、415V	
水箱容量 Tank capacity	N/A	
尺寸 Dimension (D*W*H)	1241x748x1330 mm	
重量 Weight	274 kg	

### Options 配選功能

1. 5-8 個出水口 5-8 ports outlet
2. 槍鑽檢知 Drilling output pressure detector

- 創新智能型人機介面:
  - 提供即時與歷史機台異常記錄
  - 最新觸控式界面，可設定M碼多段壓力
  - 內建定期系統保養提醒功能
- Innovative intelligent HMI interface:
  - Provide real-time and historical machine alarm records.
  - New style touch panel, using M code to set up multiple pressures.
  - Embedded periodical system maintenance reminder function.
- Energy saving more than 40%.
- Compact size, small footprint.
- Water base coolant, oil ratio 1%.
- 平均節能省電40%以上
- 體積小，節省空間
- 水基切削液，油水比例1%

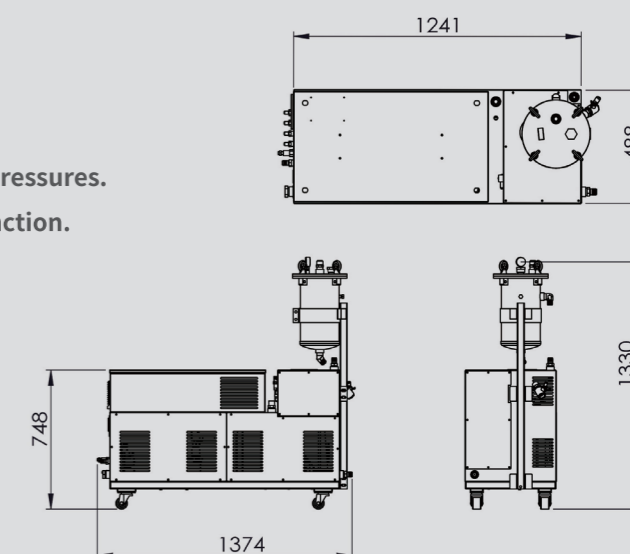

# PJ-18V0



## Specifications 基本規格表

	PJ-18V0	PJ-18A
適用液體 Fluid Type	油基切削液 (黏度係數15-32cst) Oil base coolant (viscosity 15-32cst)	
控制面板 Control Panel	人機介面 HMI Screen	PCB 電路板 / PCB Board
最大工作壓力 Max working pressure	140 Bar / 2000 PSI	
最大流量 Max flow rate	18 Liter/min	
出水口數量 Number of ports	4 (標準) (Standard)	
過濾精度 Filtration	5 $\mu$ 單過濾罐 SingleFilter (濾袋式 / Filter Bag)	
額定功率 Rated power	6.51KW	6.52KW
額定負載 Rated load	8.72HP	8.73HP
補水泵 Suction pump	內含 (Included)	
電壓 Voltage	200V、220V、380V、400V、415V	
水箱容量 Tank capacity	N/A	
尺寸 Dimension (D*W*H)	1026x624x851 mm	
重量 Weight	250 kg	

### Options 配選功能

1. 5-8 個出水口 5-8 ports outlet
2. 油冷機 Oil Chiller
3. 熱交換器 Heat exchanger
4. 槍鑽檢知 Drilling output pressure detector
5. 消泡裝置 Anti-foaming device

- PJ-Saving專利高效能低耗材系統
- 創新智能人機介面:
  - 提供即時與歷史機台異常記錄
  - 最新觸控式界面, 可設定M碼多段壓力
  - 內建定期系統保養提醒功能
- PJ-saving system (Patented high-performance & low-cost of material filtration system.)
- Innovative intelligent HMI interface:
  - Provide real-time and historical machine alarm records.
  - New style touch panel, using M code to set up multiple pressures.
  - Embedded periodical system maintenance reminder function.
- Pressure protection, to avoid waterless operation.
- Energy saving more than 40%.
- Compact size, can be placed under the bar feeders to save space.

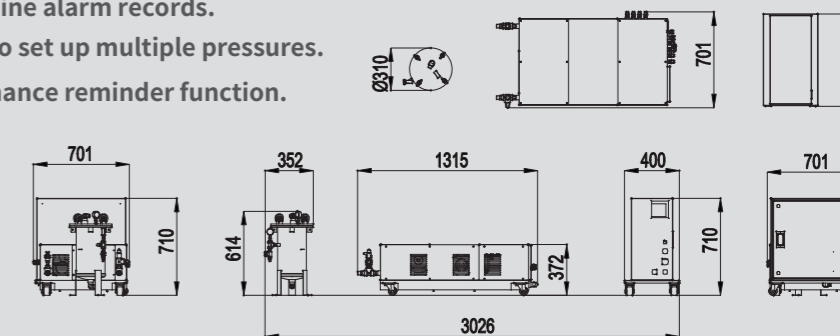

# PJ-30VT



## Specifications 基本規格表

適用液體 Fluid Type	水基切削液、油基切削液 (黏度係數15-32cst) Water base coolant, Oil base coolant (viscosity 15-32cst)					
控制面板 Control Panel	人機介面 HMI Screen					
最大工作壓力 Max working pressure	70 Bar / 1000 PSI		100 Bar / 1500 PSI		140 Bar / 2000 PSI	200 Bar / 2900PSI
最大流量 Max flow rate	30 Liter/min	43 Liter/min	27 Liter/min	30 Liter/min	24 Liter/min	18 Liter/min
出水口數量 Number of ports	1 (標準) (Standard)		1 (標準) (Standard)		4 (標準) (Standard)	
過濾精度 Filtration	5μ 單過濾罐 SingleFilter (濾袋式 / Filter Bag)					
額定功率 Rated power	8.28KW	10.28KW	8.28KW	10.28KW	10.28KW	10.98KW
額定負載 Rated load	11.09HP	13.78HP	11.09HP	13.78HP	13.78HP	14.72HP
補水泵 Suction pump	內含 (Included)					
電壓 Voltage	200V、220V、380V、400V、415V					
水箱容量 Tank capacity	140 Liter					
尺寸 Dimension (D*W*H)	1271x550x1320 mm					
重量 Weight	345 kg					

### Options 配選功能

1. 2-8 個出水口 2-8 ports outlet
2. 油冷機 Oil Chiller
3. 雙過濾罐 Dual filters
4. 槍鑽檢知 Drilling output pressure detector
5. 消泡裝置 Anti-foaming device
6. 離心過濾 Centrifugal filtration

- PJ-Saving專利高效能低耗材系統
- 創新智能型人機介面:
  - 提供即時與歷史機台異常記錄
  - 最新觸控式界面，可設定M碼多段壓力
  - 內建定期系統保養提醒功能
- PJ-saving system (Patented high-performance & low-cost of material filtration system.)
- Innovative intelligent HMI interface:
  - Provide real-time and historical machine alarm records.
  - New style touch panel, using M code to set up multiple pressures.
  - Embedded periodical system maintenance reminder function.
- Pressure protection, to avoid waterless operation.
- Energy saving more than 40%.
- Water base coolant, oil ratio 1%.
- Applicable to small aperture machining.

- 總壓保護，避免無水加工
- 均節省省電40%以上
- 水基切削液，油水比例1%
- 可適用於小孔徑加工

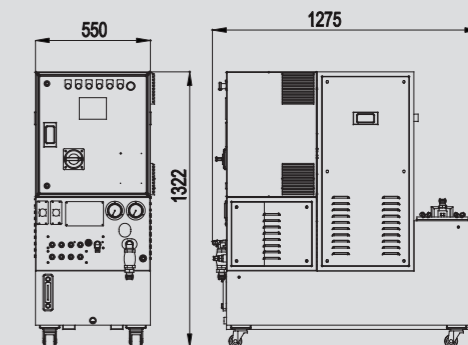
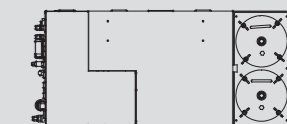

# Output Comparison of Inverter and Traditional Motors

## 變頻與傳統馬達輸出數據比較表

### 油基切削液 Oil base coolant

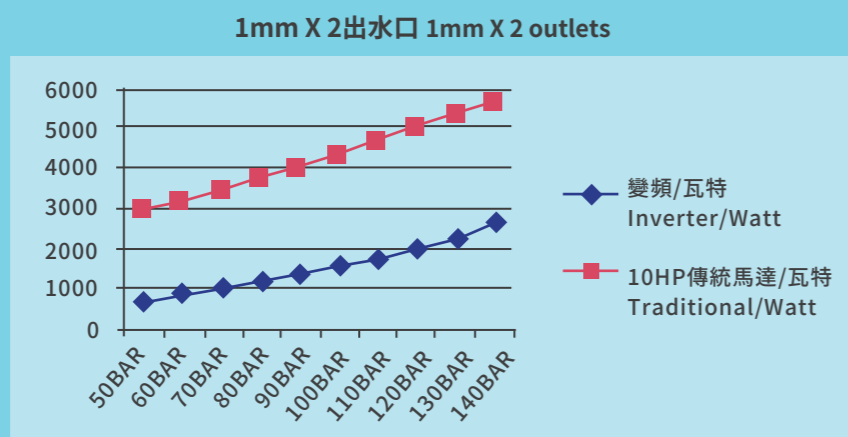

### 節能電費比較 Electricity expense comparison

1年使用250天(1天使用24小時)

- 傳統10HP馬達電費為: 116400元
- 變頻電費為: 55860元
- 變頻電費節省: 60540元

250 days/year, 24 hr/day

- Traditional 10 HP Motor: USD 3880
- Inverter Motor: USD 1862
- Electricity expense saved: USD 2018

以上資料係以140bar 1mm X 2出水孔為例:  
The above calculation is based on 140bar 1mm X 2 outlets

	耗電量(瓦特) Power consumption(Watt)	平均電價(1度3.5元) Average electricity expense(USD 0.12/degree)	使用12小時/天 12 hr/day
變頻 Inverter Motor	2662瓦特Watt	使用1小時/9.31元 USD 0.31/hr	1天111.72元 USD 3.72/day
傳統10HP馬達 Traditional 10 HP Motor	5544瓦特Watt	使用1小時/19.4元 USD 0.65/hr	1天232.8元 USD 7.76/day

### 水基切削液 Water base coolant

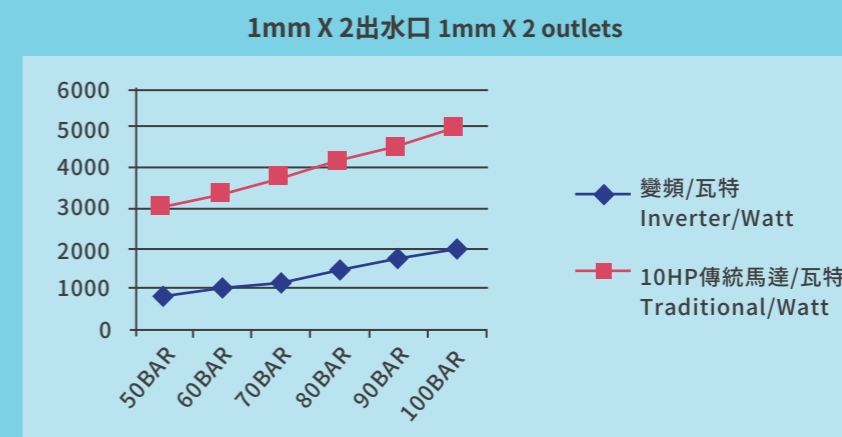

### 節能電費比較 Electricity expense comparison

1年使用250天(1天使用24小時)

- 傳統10HP馬達電費為: 104412元
- 變頻電費為: 42950元
- 變頻電費節省: 61462元

250 days/year, 24 hr/day

- Traditional 10 HP Motor: USD 3480
- Inverter Motor: USD 1432
- Electricity expense saved: USD 2049

以上資料係以140bar 1mm X 2出水孔為例:  
The above calculation is based on 140bar 1mm X 2 outlets

	耗電量(瓦特) Power consumption(Watt)	平均電價(1度3.5元) Average electricity expense(USD 0.12/degree)	使用12小時/天 12 hr/day
變頻 Inverter Motor	2046瓦特Watt	使用1小時/7.16元 USD 0.24/hr	1天85.9元 USD 2.86/day
傳統10HP馬達 Traditional 10 HP Motor	4972瓦特Watt	使用1小時/17.4元 USD 0.58/hr	1天208.8元 USD 6.96/day

注：本節能數據為PJ-VT系列連續使用24HR，油水比例8%所測得，實際加工時，因受客戶加工習慣與切削水油水比例不同，或機台(零件)未保養等因素，其實際節能數據可能會有差異。

This energy saving parameters are obtained by testing PJ-VT series 24hours continuously, with oil ration 8% coolant. The actual results might be different with different machining process and oil ratios will also have impact on test results machine (parts) not regularly maintained and other factors during actual operation.

# PJ-30MT



## Specifications 基本規格表

適用液體 Fluid Type	水基切削液、油基切削液 (黏度係數15-32cst) Water base coolant, Oil base coolant (viscosity 15-32cst)					
控制面板 Control Panel	PCB 電路板 / PCB Board					
最大工作壓力 Max working pressure	70 Bar / 1000 PSI		100 Bar / 1500 PSI		140 Bar / 2000 PSI	200 Bar / 2900PSI
最大流量 Max flow rate	30 Liter/min	43 Liter/min	27 Liter/min	30 Liter/min	24 Liter/min	18 Liter/min
出水口數量 Number of ports	1 (標準) (Standard)		1 (標準) (Standard)		4 (標準) (Standard)	
過濾精度 Filtration	5μ 單過濾罐 SingleFilter (濾袋式 / Filter Bag)					
額定功率 Rated power	8.17KW	10.17KW	8.17KW	10.17KW	10.17KW	10.87KWt
額定負載 Rated load	10.95HP	13.63HP	10.95HP	13.63HP	13.63HP	14.57HP
補水泵 Suction pump	內含 (Included)					
電壓 Voltage	200V、220V、380V、400V、415V					
水箱容量 Tank capacity	140 Liter					
尺寸 Dimension (D*W*H)	1271x550x1320 mm					
重量 Weight	345 kg					

### Options 配選功能

- 2-8 個出水口 2-8 ports outlet
- 油冷機 Oil Chiller
- 雙過濾罐 Dual filters
- 槍鑽檢知 Drilling output pressure detector
- 消泡裝置 Anti-foaming device
- 離心過濾 Centrifugal filtration

- PJ-Saving專利高效能低耗材系統
- 電控面板模組化，便於維修
- 直覺式操控面板，易於操作
- 副水箱設計，減低熱能及氣泡
- 切削油水比例1%
- PJ-saving system  
(Patented high-performance & low-cost of material filtration system.)
- Modular PCB, easy for maintenance.
- Intuitive control panel, easy for operation.
- With secondary tank design to reduce heat and foaming.
- Coolant oil ratio 1%.

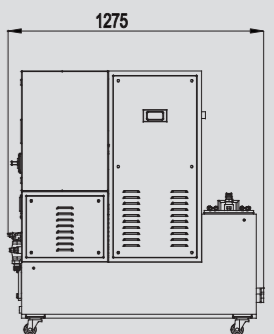
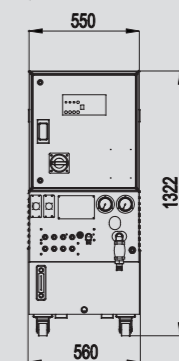



# PJ-22VT



## Specifications 基本規格表

適用液體 Fluid Type	油基切削液 (黏度係數15-32cst) Oil base coolant (viscosity 15-32cst)
控制面板 Control Panel	人機介面 HMI Screen
最大工作壓力 Max working pressure	140 Bar / 2000 PSI
最大流量 Max flow rate	22 Liter/min
出水口數量 Number of ports	4 (標準) (Standard)
過濾精度 Filtration	5μ 單過濾罐 Single Filter (濾袋式 / Filter Bag)
額定功率 Rated power	8.51KW
額定負載 Rated load	11.4HP
補水泵 Suction pump	內含 (Included)
電壓 Voltage	200V、220V、380V、400V、415V
水箱容量 Tank capacity	83 Liter
尺寸 Dimension (D*W*H)	1456x690x1348 mm
重量 Weight	274 kg

### Options 配選功能

1. 2-8 個出水口 2-8 ports outlet    2. 油冷機 Oil Chiller    3. 槍鑽檢知 Drilling output pressure detector

- 平均節能省電40%以上
- 可用M碼設定多段壓力，方便省時
- 人機介面為標準配備
- 專門為走心式車床所設計
- 適合槍鑽以及深孔加工
- Energy saving more than 40%
- Using M code to set up multiple pressures.
- HMI as standard.
- Customized design for Swiss turning lathe.
- Ideal for gun drilling and cannulation applications.

# PJ-20S



# PJ-32M



## Specifications 基本規格表

	PJ-20S	PJ-32M
適用液體 Fluid Type	油基切削液 (黏度係數15-32cst) Oil base coolant (viscosity 15-32cst)	水基切削液 (油水比例最低須為10%以上) Water base coolant (oil ration must be at least 10% or higher)
控制面板 Control Panel	PCB 電路板 / PCB Board	
最大工作壓力 Max working pressure	40 Bar / 580 PSI	
最大流量 Max flow rate	20 Liter/min	32 Liter/min
出水口數量 Number of ports	3 (標準) (Standard)	1 (標準) (Standard)
過濾精度 Filtration	5μ 單過濾罐 SingleFilter (濾袋式 / Filter Bag)	
額定功率 Rated power	3.6KW	
額定負載 Rated load	4.82HP	
補水泵 Suction pump	內含 (Included)	
電壓 Voltage	200V、220V、380V、400V、415V	
水箱容量 Tank capacity	N/A	
尺寸 Dimension (D*W*H)	532x695x943 mm	600x695x820 mm
重量 Weight	98 kg	123 kg

### Options 配選功能

1. 4 個出水口 4 ports outlet 2. 80Liter 副水箱 80Liter Tank 3. 消泡裝置 Anti-foaming device 4. 雙過濾罐 Dual filters

- 電控面板模組化，便於維修
- 直覺式操控面板，易於操作
- 三組M碼輸出
- 體積小，空間省
- Modular PCB, easy to maintenance.
- Intuitive control panel, easy for operation.
- 3 sets of M code output.
- Compact size, small footprint.

## 客製機

## Customized Model

### Specification 基本規格表

適用液體 Fluid Type	水基切削液、油基切削液 (黏度係數15-32cst) Water base coolant, Oil base coolant (viscosity 15-32cst)
最大工作壓力 Max working pressure	30-250 Bar / 435- 3600 PSI
最大流量 Max flow rate	10-75 Liter/min
出水口數量 Number of ports	1-8 (標準) (Standard)
過濾精度 Filtration	5μ-25μ 單過濾罐 SingleFilter/ 雙過濾罐 Dual Filter (濾袋式 / Filter Bag)
電壓 Voltage	200V、220V、380V、400V、415V

- 可依照客戶需求特製
- Customization according to customers' requirement

