

EFFICIENCY MILLS

ELD

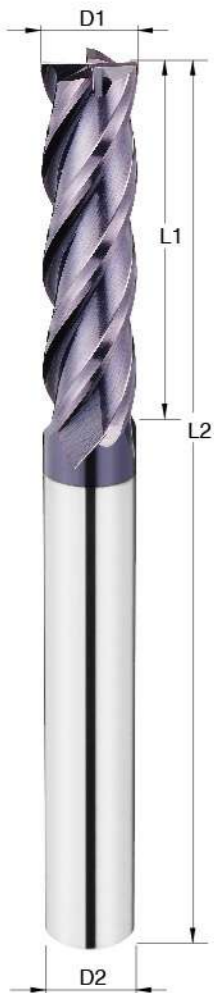

MG

4 Flutes

35°

HRC 55

TiAlN

Finishing
Semi-Finishing

Planing

Side

▶ Long Flute / Square / for **P** **K** unit: mm

Order No.	Diameter D1	Flute Length L1	O.A.L. L2	Shank Dia D2
ELD 0204	2.0	15	50	4
ELD 0304	3.0	20	50	4
ELD 0404	4.0	25	75	4
ELD 0506	5.0	30	75	6
ELD 0606	6.0	30	75	6
ELD 0808	8.0	40	100	8
ELD 1010	10.0	40	100	10
ELD 1212	12.0	45	100	12
ELD 1616	16.0	60	150	16
ELD 2020	20.0	60	150	20

▼ Recommended cutting condition for ELD

MATERIAL	Carbon Steels . Alloy Steels S45C, FC, FCD, SCM, S50C, SKS...		Alloy Steels . Tool Steels SCr, SNCM, SKD11, SKD61, NAK80...		Hardened Steels SKD11	
	~HRC30		~HRC50		~HRC60	
HARDNESS	SPEED (min ⁻¹)	FEED mm / min	SPEED (min ⁻¹)	FEED mm / min	SPEED (min ⁻¹)	FEED mm / min
2	3000	50	2500	40	1000	15
3	2500	60	2000	50	800	20
4	2000	80	1700	70	700	30
5	1800	110	1500	85	600	40
6	1500	110	1400	75	550	50
8	1300	110	1100	75	450	50
10	1000	110	800	75	300	50
12	900	110	700	75	250	40
16	800	95	500	70	150	20
20	500	80	400	60	120	20

▼ Depth of cut

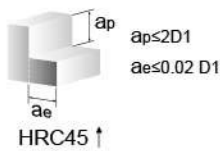
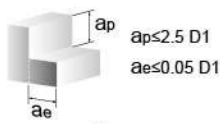

EFFICIENCY MILLS

EH



MG

6 Flutes

45°

HRC 55

TiAlN

Finishing

Side

▶ Square / for **P** **K** unit: mm

Order No.	Diameter D1	Flute Length L1	O.A.L. L2	Shank Dia D2
EH 0606	6.0	16	50	6
EH 0808	8.0	20	60	8
EH 1010	10.0	25	75	10
EH 1212	12.0	30	75	12
EH 1616	16.0	40	100	16
EH 2020	20.0	45	100	20

▼ Depth of cut

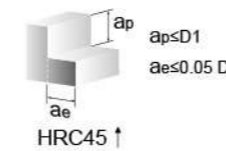
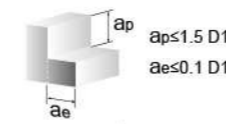

▼ Recommended cutting condition for EH

MATERIAL	Carbon Steels . Alloy Steels S45C, FC, FCD, SCM, S50C, SKS...		Alloy Steels . Tool Steels SCr, SNCM, SKD11, SKD61, NAK80...		Hardened Steels SKD11	
	~HRC30		~HRC50		~HRC60	
HARDNESS	SPEED (min ⁻¹)	FEED mm / min	SPEED (min ⁻¹)	FEED mm / min	SPEED (min ⁻¹)	FEED mm / min
6	5500	1000	4500	850	3800	650
8	4000	1000	3500	850	3000	650
10	3300	1000	3100	850	2400	650
12	3000	900	2500	700	2000	600
16	2500	700	2000	550	1500	450
20	1800	550	1500	420	1200	380

EFFICIENCY MILLS

EHL

► Long Flute / Square / for **P** **K** unit: mm

Order No.	Diameter D1	Flute Length L1	O.A.L. L2	Shank Dia D2
EHL 0606	6.0	24	75	6
EHL 0808	8.0	32	75	8
EHL 1010	10.0	40	100	10
EHL 1212	12.0	45	100	12
EHL 1616	16.0	64	150	16
EHL 2020	20.0	75	150	20



MG

6 Flutes

45°

HRC 55

TiAlN

Finishing

Side

▼ Depth of cut

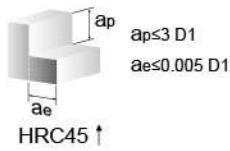
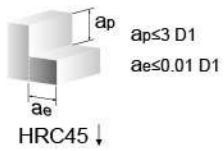

▼ Recommended cutting condition for EHL

MATERIAL	Carbon Steels . Alloy Steels S45C, FC, FCD, SCM, S50C, SKS...		Alloy Steels . Tool Steels SCr, SNCM, SKD11, SKD61, NAK80...		Hardened Steels SKD11	
	~HRC30		~HRC50		~HRC60	
HARDNESS	~HRC30		~HRC50		~HRC60	
Dia. (D1)	SPEED (min ⁻¹)	FEED mm / min	SPEED (min ⁻¹)	FEED mm / min	SPEED (min ⁻¹)	FEED mm / min
6	1900	400	1500	300	1200	220
8	1500	380	1100	280	900	200
10	1200	360	850	260	750	190
12	1000	340	700	230	650	180
16	750	280	550	200	450	150
20	600	240	450	170	350	120

EFFICIENCY MILLS

EG

► Roughing / Square / for **P** **K** unit: mm

Order No.	Diameter D1	Flute Length L1	O.A.L. L2	Shank Dia D2
EG 0606	6.0	16	50	6
EG 0808	8.0	20	60	8
EG 1010	10.0	25	75	10
EG 1212	12.0	30	75	12
EG 1616	16.0	40	100	16
EG 2020	20.0	45	100	20



MG

3 Flutes

Fine

45°

HRC 55

TiAlN

Roughing

Slotting

Side

▼ Depth of cut

Side Milling



Grooving

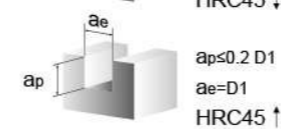

▼ Recommended cutting condition for EG

MATERIAL	Carbon Steels . Alloy Steels S45C, FC, FCD, SCM, S50C, SKS...		Alloy Steels . Tool Steels SCr, SNCM, SKD11, SKD61, NAK80...		Hardened Steels SKD11	
	~HRC30		~HRC50		~HRC60	
HARDNESS	~HRC30		~HRC50		~HRC60	
Dia. (D1)	SPEED (min ⁻¹)	FEED mm / min	SPEED (min ⁻¹)	FEED mm / min	SPEED (min ⁻¹)	FEED mm / min
6	5500	550	3000	310	1150	120
8	4600	550	2500	310	920	120
10	3700	550	2000	310	730	120
12	3000	500	1700	310	600	120
16	2300	520	1200	310	460	120
6	4400	440	2400	250	920	100
8	3600	440	2000	250	730	100
10	3000	440	1600	250	580	100
12	2400	440	1350	250	480	100
16	1800	440	960	250	370	100

EFFICIENCY MILLS

EGA

► Roughing / Square / for **P** **K** unit: mm

Order No.	Diameter D1	Flute Length L1	O.A.L. L2	Shank Dia D2
EGA 0606	6.0	16	50	6
EGA 0808	8.0	20	60	8
EGA 1010	10.0	25	75	10
EGA 1212	12.0	30	75	12
EGA 1616	16.0	40	100	16
EGA 2020	20.0	45	100	20



- MG**
- 4 Flutes
- Fine
- 35°
- HRC 55
- TiAlN
- Roughing
- Slotting
- Side

▼ Depth of cut

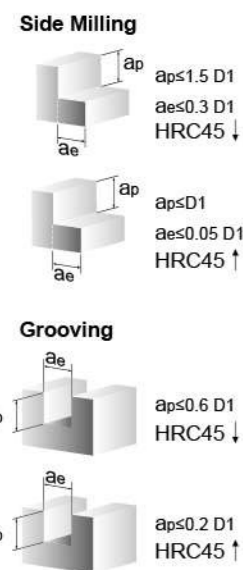

▼ Recommended cutting condition for EGA

MATERIAL	Carbon Steels . Alloy Steels S45C, FC, FCD, SCM, S50C, SKS...		Alloy Steels . Tool Steels SCR, SNCM, SKD11, SKD61, NAK80...		Hardened Steels SKD11	
	~HRC30		~HRC50		~HRC60	
	Dia. (D1)	SPEED (min ⁻¹)	FEED mm / min	SPEED (min ⁻¹)	FEED mm / min	FEED mm / min
Side Milling	6	5500	550	3000	310	1150
	8	4600	550	2500	310	920
	10	3700	550	2000	310	730
	12	3000	500	1700	310	600
Grooving	6	4400	440	2400	250	920
	8	3600	440	2000	250	730
	10	3000	440	1600	250	580
	12	2400	440	1350	250	480
	16	1800	440	960	250	370

EFFICIENCY MILLS

ETL

► Long Flute . Taper / for **P** **K** unit: mm

Order No.	Small Mill Dia D1	Flute Length L1	Taper Angle β	Large Mill Dia D3	O.A.L. L2	Shank Dia D2
ETL 01005	1.0	10	30°	1.17	50	4
ETL 01010	1.0	10	1°	1.35	50	4
ETL 01015	1.0	10	1° 30'	1.52	50	4
ETL 01020	1.0	10	2°	1.70	50	4
ETL 01025	1.0	10	2° 30'	1.87	50	4
ETL 01030	1.0	10	3°	2.05	50	4
ETL 01050	1.0	10	5°	2.74	50	4
ETL 01070	1.0	10	7°	3.44	50	4
ETL 01505	1.5	10	30°	1.67	50	4
ETL 01510	1.5	10	1°	1.87	50	4
ETL 01515	1.5	10	1° 30'	2.02	50	4
ETL 01520	1.5	10	2°	2.20	50	4
ETL 01525	1.5	10	2° 30'	2.37	50	4
ETL 01530	1.5	10	3°	2.55	50	4
ETL 02005	2.0	13	30°	2.22	50	4
ETL 02010	2.0	13	1°	2.45	50	4
ETL 02015	2.0	13	1° 30'	2.68	50	4
ETL 02020	2.0	13	2°	2.90	50	4
ETL 02025	2.0	13	2° 30'	3.13	50	4
ETL 02030	2.0	13	3°	3.36	50	4
ETL 02050	2.0	13	5°	4.27	50	6
ETL 02505	2.5	15	30°	2.76	50	4
ETL 02510	2.5	15	1°	3.03	50	4
ETL 02515	2.5	15	1° 30'	3.29	50	4
ETL 02520	2.5	15	2°	3.56	50	4
ETL 02525	2.5	15	2° 30'	3.81	50	4
ETL 02530	2.5	15	3°	4.07	50	6
ETL 02550	2.5	15	5°	5.13	50	6
ETL 03005	3.0	20	30°	3.35	60	6
ETL 03010	3.0	20	1°	3.70	60	6
ETL 03015	3.0	20	1° 30'	4.05	60	6
ETL 03020	3.0	20	2°	4.39	60	6
ETL 03025	3.0	20	2° 30'	4.65	60	6
ETL 03030	3.0	20	3°	5.10	60	6
ETL 03050	3.0	20	5°	6.50	60	8
ETL 04005	4.0	25	30°	4.44	60	6
ETL 04010	4.0	25	1°	4.88	60	6
ETL 04015	4.0	25	1° 30'	5.13	60	6
ETL 04020	4.0	25	2°	5.75	60	6
ETL 04025	4.0	25	2° 30'	6.19	60	8
ETL 04030	4.0	25	3°	6.62	60	8
ETL 04050	4.0	25	5°	8.38	75	10

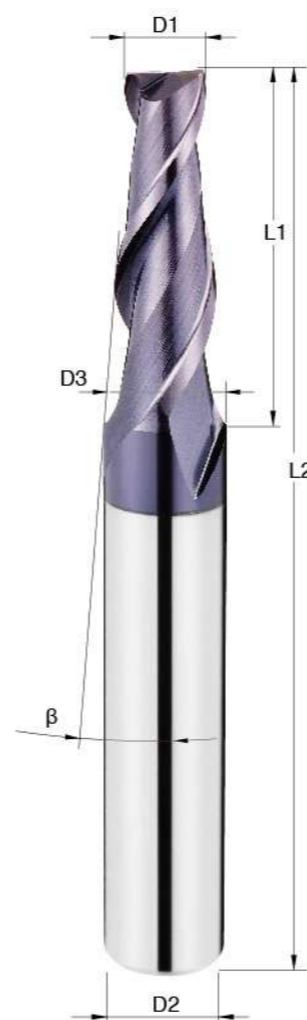

- MG**
- 2 Flutes
- 35°
- HRC 55
- TiAlN
- Finishing / Semi-Finishing
- Side

▼ Depth of cut

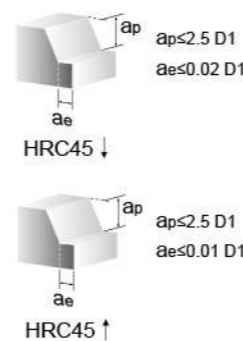

▼ Recommended cutting condition for ETL

MATERIAL	Carbon Steels . Alloy Steels S45C, FC, FCD, SCM, S50C, SKS...		Alloy Steels . Tool Steels SCR, SNCM, SKD11, SKD61, NAK80...		Hardened Steels SKD11	
	~HRC30		~HRC50		~HRC60	
	Dia. (D1)	SPEED (min ⁻¹)	FEED mm / min	SPEED (min ⁻¹)	FEED mm / min	FEED mm / min
	1	12000	65	6800	40	2500
	1.5	9600	70	5200	45	2000
	2	7500	85	4000	48	1500
	2.5	6800	100	3700	60	1700
	4	3500	120	1800	60	600

EFFICIENCY MILLS

ET

▶ Taper Flute / for

P K

unit: mm

Order No.	Small Mill Dia D1	Flute Length L1	Taper Angle β	Large Mill Dia D3	O.A.L. L2	Shank Dia D2
ET 005005	0.5	2	30'	0.53	50	4
ET 005010	0.5	2	1°	0.57	50	4
ET 005015	0.5	2	1° 30'	0.60	50	4
ET 005020	0.5	2	2°	0.64	50	4
ET 005025	0.5	2	2° 30'	0.67	50	4
ET 005030	0.5	2	3°	0.71	50	4
ET 005050	0.5	2	5°	0.85	50	4
ET 005070	0.5	2	7°	0.99	50	4
ET 005100	0.5	2	10°	1.21	50	4
ET 010005	1.0	4	30'	1.07	50	4
ET 010010	1.0	4	1°	1.14	50	4
ET 010015	1.0	4	1° 30'	1.21	50	4
ET 010020	1.0	4	2°	1.28	50	4
ET 010025	1.0	4	2° 30'	1.35	50	4
ET 010030	1.0	4	3°	1.42	50	4
ET 010050	1.0	4	5°	1.70	50	4
ET 010070	1.0	4	7°	1.98	50	4
ET 010100	1.0	4	10°	2.41	50	4
ET 015005	1.5	5	30'	1.59	50	4
ET 015010	1.5	5	1°	1.67	50	4
ET 015015	1.5	5	1° 30'	1.76	50	4
ET 015020	1.5	5	2°	1.85	50	4
ET 015025	1.5	5	2° 30'	1.93	50	4
ET 015030	1.5	5	3°	2.02	50	4
ET 015050	1.5	5	5°	2.37	50	4
ET 015070	1.5	5	7°	2.72	50	4
ET 015100	1.5	5	10°	3.26	50	4
ET 020005	2.0	6	30'	2.10	50	4
ET 020010	2.0	6	1°	2.21	50	4
ET 020015	2.0	6	1° 30'	2.31	50	4
ET 020020	2.0	6	2°	2.41	50	4
ET 020025	2.0	6	2° 30'	2.52	50	4
ET 020030	2.0	6	3°	2.62	50	4
ET 020050	2.0	6	5°	3.05	50	4
ET 020070	2.0	6	7°	3.47	50	4
ET 020100	2.0	6	10°	4.11	50	4
ET 025005	2.5	8	30'	2.64	50	4
ET 025010	2.5	8	1°	2.78	50	4
ET 025015	2.5	8	1° 30'	2.91	50	4
ET 025020	2.5	8	2°	3.05	50	4
ET 025025	2.5	8	2° 30'	3.20	50	4
ET 025030	2.5	8	3°	3.33	50	4
ET 025050	2.5	8	5°	3.90	50	4
ET 025070	2.5	8	7°	4.46	50	6
ET 025100	2.5	8	10°	5.32	50	6
ET 030005	3.0	10	30'	3.17	50	6
ET 030010	3.0	10	1°	3.35	50	6
ET 030015	3.0	10	1° 30'	3.52	50	6
ET 030020	3.0	10	2°	3.69	50	6
ET 030025	3.0	10	2° 30'	3.87	50	6
ET 030030	3.0	10	3°	4.05	50	6
ET 030050	3.0	10	5°	4.75	50	6
ET 030070	3.0	10	7°	5.46	50	6
ET 030100	3.0	10	10°	6.53	60	8
ET 040005	4.0	15	30'	4.26	50	6
ET 040010	4.0	15	1°	4.52	50	6
ET 040015	4.0	15	1° 30'	4.79	50	6
ET 040020	4.0	15	2°	5.04	50	6
ET 040025	4.0	15	2° 30'	5.31	50	6
ET 040030	4.0	15	3°	5.57	50	6

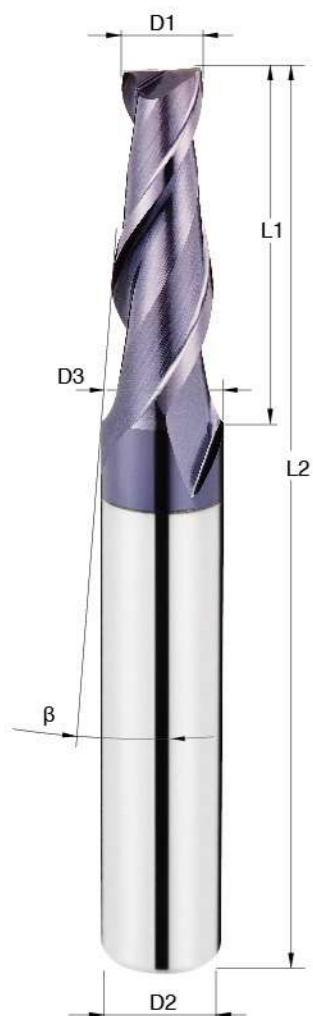

MG

2 Flutes

35°

HRC 55

TiAlN

Finishing
Semi-Finishing

Side

▼ Depth of cut



HRC45 ↓

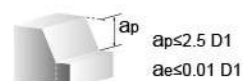

HRC45 ↑

EFFICIENCY MILLS

ET

▶ Taper Flute / for

P K

unit: mm

Order No.	Small Mill Dia D1	Flute Length L1	Taper Angle β	Large Mill Dia D3	O.A.L. L2	Shank Dia D2
ET 040050	4.0	15	5°	6.62	60	8
ET 040070	4.0	15	7°	7.68	60	8
ET 050005	5.0	20	30'	5.34	60	6
ET 050010	5.0	20	1°	5.70	60	6
ET 050015	5.0	20	1° 30'	6.04	60	8
ET 050020	5.0	20	2°	6.39	60	8
ET 050025	5.0	20	2° 30'	6.74	60	8
ET 050030	5.0	20	3°	7.10	60	8
ET 050050	5.0	20	5°	8.50	75	10
ET 050070	5.0	20	7°	9.91	75	10
ET 060005	6.0	20	30'	6.35	60	8
ET 060010	6.0	20	1°	6.70	60	8
ET 060015	6.0	20	1° 30'	7.05	60	8
ET 060020	6.0	20	2°	7.40	60	8
ET 060025	6.0	20	2° 30'	7.75	60	8
ET 060030	6.0	20	3°	8.10	60	8
ET 060050	6.0	20	5°	9.50	75	10
ET 080005	8.0	25	30'	8.44	75	10
ET 080010	8.0	25	1°	8.87	75	10
ET 080015	8.0	25	1° 30'	9.31	75	10
ET 080020	8.0	25	2°	9.74	75	10
ET 080025	8.0	25	2° 30'	10.18	75	12
ET 080030	8.0	25	3°	10.62	75	12
ET 080050	8.0	25	5°	12.37	100	16
ET 100005	10.0	35	30'	10.61	100	12
ET 100010	10.0	35	1°	11.22	100	12
ET 100015	10.0	35	1° 30'	11.83	100	12
ET 100020	10.0	35	2°	12.44	100	16
ET 100025	10.0	35	2° 30'	13.06	100	16
ET 100030	10.0	35	3°	13.67	100	16
ET 100050	10.0	35	5°	16.12	100	16

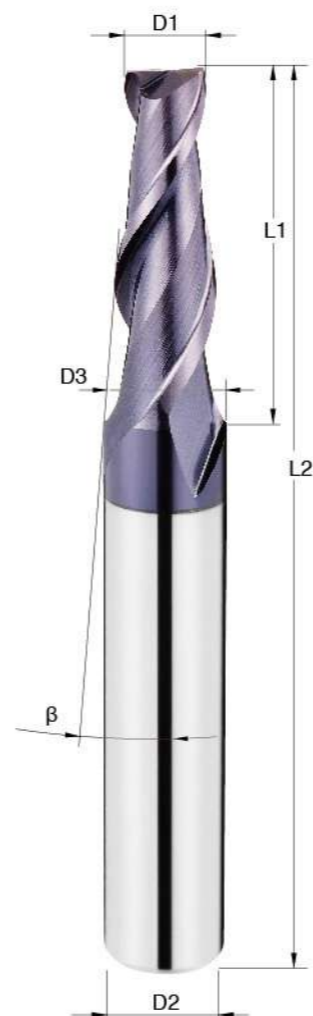

MG

2 Flutes

35°

HRC 55

TiAlN

Finishing
Semi-Finishing

Side

▼ Depth of cut

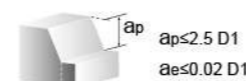

HRC45 ↓



HRC45 ↑

▼ Recommended cutting condition for ET

MATERIAL	Carbon Steels . Alloy Steels S45C, FC, FCD, SCM, S50C, SKS...		Alloy Steels . Tool Steels SCr, SNCM, SKD11, SKD61, NAK80...		Hardened Steels SKD11		
	~HRC30		~HRC50		~HRC60		
HARDNESS	Dia. (D1)	SPEED (min ⁻¹)	FEED mm / min	SPEED (min ⁻¹)	FEED mm / min	SPEED (min ⁻¹)	FEED mm / min
	1	12000	65	6800	40	2500	15
	1.5	9600	70	5200	45	2000	15
	2	7500	85	4000	48	1500	18
	2.5	6800	100	3700	60	1700	20
	4	3500	120	1800	60	600	20
	6	2500	150	1600	80	550	25
	8	2000	150	1200	80	450	25
	10	1500	150	1000	80	350	25

EFFICIENCY MILLS

ERA



MG

2 Flutes

35°

R

HRC 55

TiAlN

Finishing

Semi-Finishing

Slotting

Profiling

Corner Radius / for **P** **K** unit: mm

Order No.	Diameter D1	Corner R R	Flute Length L1	O.A.L. L2	Shank Dia D2
ERA 0302	3.0	0.2	6	50	3
ERA 0305	3.0	0.5	6	50	3
ERA 0402	4.0	0.2	8	50	4
ERA 0405	4.0	0.5	8	50	4
ERA 0410	4.0	1.0	8	50	4
ERA 0602	6.0	0.2	12	50	6
ERA 0605	6.0	0.5	12	50	6
ERA 0610	6.0	1.0	12	50	6
ERA 0615	6.0	1.5	12	50	6
ERA 0620	6.0	2.0	12	50	6
ERA 0803	8.0	0.3	16	60	8
ERA 0805	8.0	0.5	16	60	8
ERA 0810	8.0	1.0	16	60	8
ERA 0815	8.0	1.5	16	60	8
ERA 0820	8.0	2.0	16	60	8
ERA 1005	10.0	0.5	20	75	10
ERA 1010	10.0	1.0	20	75	10
ERA 1015	10.0	1.5	20	75	10
ERA 1020	10.0	2.0	20	75	10
ERA 1030	10.0	3.0	20	75	10
ERA 1205	12.0	0.5	24	75	12
ERA 1210	12.0	1.0	24	75	12
ERA 1215	12.0	1.5	24	75	12
ERA 1220	12.0	2.0	24	75	12
ERA 1230	12.0	3.0	24	75	12

▼ Depth of cut

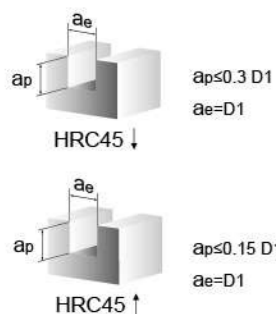

▼ Recommended cutting condition for ERA

MATERIAL	Carbon Steels . Alloy Steels S45C, FC, FCD, SCM, S50C, SKS...		Alloy Steels . Tool Steels SCr, SNCM, SKD11, SKD61, NAK80...		Hardened Steels SKD11		
	~HRC30		~HRC50		~HRC60		
HARDNESS	Dia. (D1)	SPEED (min ⁻¹)	FEED mm / min	SPEED (min ⁻¹)	FEED mm / min	SPEED (min ⁻¹)	FEED mm / min
	3	7600	180	4800	120	2900	50
	4	6500	260	4000	160	2500	55
	5	5500	270	3200	160	2000	60
	6	4800	300	2900	170	1800	70
	8	3700	325	2200	170	1500	85
	10	2900	280	1700	140	1100	70
	12	2400	230	1400	120	1000	65
	16	1800	170	1100	90	700	45

EFFICIENCY MILLS

ERB



MG

4 Flutes

35°

R

HRC 55

TiAlN

Finishing

Semi-Finishing

Side

Profiling

Corner Radius / for **P** **K** unit: mm

Order No.	Diameter D1	Corner R R	Flute Length L1	O.A.L. L2	Shank Dia D2
ERB 0302	3.0	0.2	6	50	3
ERB 0302.4	3.0	0.2	6	50	4
ERB 0305	3.0	0.5	6	50	3
ERB 0305.4	3.0	0.5	6	50	4
ERB 0310	3.0	1.0	6	50	3
ERB 0310.4	3.0	1.0	6	50	4
ERB 0402	4.0	0.2	8	50	4
ERB 0405	4.0	0.5	8	50	4
ERB 0410	4.0	1.0	8	50	4
ERB 0602	6.0	0.2	12	50	6
ERB 0605	6.0	0.5	12	50	6
ERB 0610	6.0	1.0	12	50	6
ERB 0615	6.0	1.5	12	50	6
ERB 0620	6.0	2.0	12	50	6
ERB 0803	8.0	0.3	16	60	8
ERB 0805	8.0	0.5	16	60	8
ERB 0810	8.0	1.0	16	60	8
ERB 0815	8.0	1.5	16	60	8
ERB 0820	8.0	2.0	16	60	8
ERB 1005	10.0	0.5	20	75	10
ERB 1010	10.0	1.0	20	75	10
ERB 1015	10.0	1.5	20	75	10
ERB 1020	10.0	2.0	20	75	10
ERB 1030	10.0	3.0	20	75	10
ERB 1205	12.0	0.5	24	75	12
ERB 1210	12.0	1.0	24	75	12
ERB 1215	12.0	1.5	24	75	12
ERB 1220	12.0	2.0	24	75	12
ERB 1230	12.0	3.0	24	75	12

▼ Depth of cut

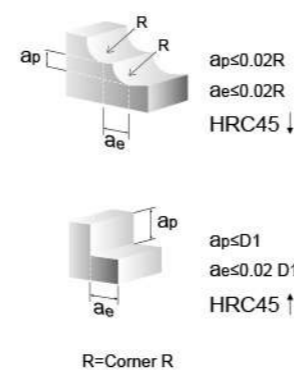

R=Corner R

▼ Recommended cutting condition for ERB

MATERIAL	Carbon Steels . Alloy Steels S45C, FC, FCD, SCM, S50C, SKS...		Alloy Steels . Tool Steels SCr, SNCM, SKD11, SKD61, NAK80...		Hardened Steels SKD11		
	~HRC30		~HRC50		~HRC60		
HARDNESS	Dia. (D1)	SPEED (min ⁻¹)	FEED mm / min	SPEED (min ⁻¹)	FEED mm / min	SPEED (min ⁻¹)	FEED mm / min
	3	9500	450	6000	290	3600	120
	4	8000	800	5000	480	3200	160
	5	6800	820	4000	500	2500	170
	6	6000	900	3600	530	2300	220
	8	4600	1000	2800	530	1800	250
	10	3500	850	2200	420	1400	220
	12	3000	720	1800	350	1200	200
	16	2300	520	1400	250	900	150

EFFICIENCY MILLS

ERC

► Long Shank Corner Radius / for **P** **K** unit: mm

Order No.	Diameter D1	Corner R R	Flute Length L1	O.A.L. L2	Shank Dia D2
ERC 0605	6.0	0.5	12	75	6
ERC 0605A	6.0	0.5	12	100	6
ERC 0610	6.0	1.0	12	75	6
ERC 0610A	6.0	1.0	12	100	6
ERC 0805	8.0	0.5	16	100	8
ERC 0810	8.0	1.0	16	100	8
ERC 1005	10.0	0.5	20	100	10
ERC 1010	10.0	1.0	20	100	10
ERC 1020	10.0	2.0	20	100	10
ERC 1205	12.0	0.5	24	100	12
ERC 1210	12.0	1.0	24	100	12
ERC 1220	12.0	2.0	24	100	12

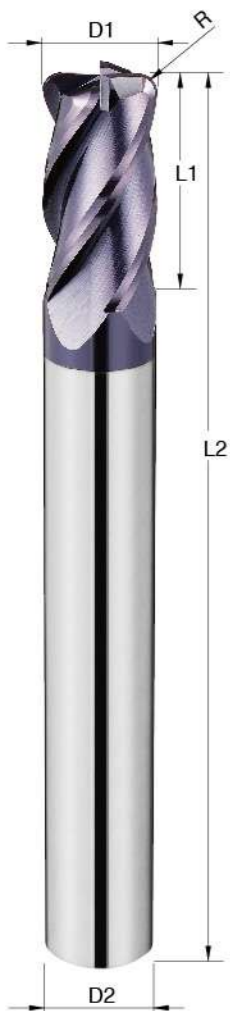

MG

4 Flutes

35°

R

HRC 55

TiAlN

Finishing
Semi-Finishing

Side

Profiling

▼ Depth of cut

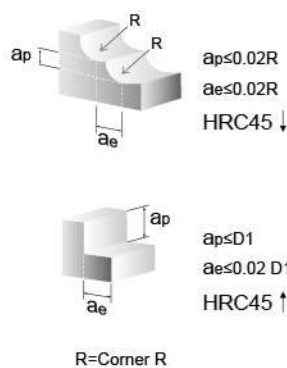

▼ Recommended cutting condition for ERC

MATERIAL	Carbon Steels . Alloy Steels S45C, FC, FCD, SCM, S50C, SKS...		Alloy Steels . Tool Steels SCr, SNCM, SKD11, SKD61, NAK80...		Hardened Steels SKD11	
	SPEED (min ⁻¹)	FEED mm / min	SPEED (min ⁻¹)	FEED mm / min	SPEED (min ⁻¹)	FEED mm / min
HARDNESS	~HRC30		~HRC50		~HRC60	
Dia. (D1)						
6	4800	2560	2900	330	1800	140
8	3700	620	2200	330	1500	160
10	2900	530	1700	260	1100	140
12	2400	450	1400	220	1000	125

EFFICIENCY MILLS

BF

► Long Neck / Ball Nose / for **P** **K** unit: mm

Order No.	Radius R	Neck Dia D3	Flute Length L1	Effective Length L3	O.A.L. L2	Shank Dia D2
BF 01006	R0.5	0.95	2	6	50	4
BF 01008	R0.5	0.95	2	8	50	4
BF 01010	R0.5	0.95	2	10	50	4
BF 01012	R0.5	0.95	2	12	50	4
BF 01508	R0.75	1.45	3	8	50	4
BF 01510	R0.75	1.45	3	10	50	4
BF 01512	R0.75	1.45	3	12	50	4
BF 01516	R0.75	1.45	3	16	50	4
BF 01520	R0.75	1.45	3	20	50	4
BF 02008	R1.0	1.92	4	8	50	4
BF 02010	R1.0	1.92	4	10	50	4
BF 02012	R1.0	1.92	4	12	50	4
BF 02016	R1.0	1.92	4	16	50	4
BF 02020	R1.0	1.92	4	20	50	4
BF 03008	R1.5	2.90	6	8	50	6
BF 03010	R1.5	2.90	6	10	50	6
BF 03012	R1.5	2.90	6	12	50	6
BF 03016	R1.5	2.90	6	16	50	6
BF 03020	R1.5	2.90	6	20	75	6
BF 03025	R1.5	2.90	6	25	75	6
BF 04012	R2.0	3.88	8	12	50	6
BF 04016	R2.0	3.88	8	16	50	6
BF 04020	R2.0	3.88	8	20	50	6
BF 04025	R2.0	3.88	8	25	75	6
BF 04030	R2.0	3.88	8	30	75	6



MG

2 Flutes

30°

HRC 55

TiAlN

Finishing
Semi-Finishing

Profiling

▼ Depth of cut

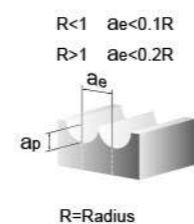

▼ Recommended cutting condition for BF

MATERIAL	Alloy Steels . Tool Steels . Hardened Steels S45C, SCM, S50C, SKS, SCr, SNCM, SKD11, SKD61, NAK80				
	RADIUS (R)	EFFECTIVE LENGTH	SPEED (min ⁻¹)	FEED mm / min	DEPTH OF CUT ap (mm)
R0.5	6	6	20000 - 32000	300 - 750	0.04
	8	8	20000 - 32000	300 - 750	0.03
	10	10	20000 - 32000	300 - 750	0.025
	12	12	20000 - 32000	300 - 750	0.015
R0.75	8	8	18000 - 20000	350 - 550	0.07
	12	12	18000 - 20000	350 - 550	0.04
	16	16	18000 - 20000	350 - 550	0.03
	20	20	18000 - 20000	350 - 550	0.02
R1.0	8	8	12000 - 17000	500 - 900	0.1
	12	12	12000 - 17000	500 - 900	0.1
	16	16	12000 - 17000	500 - 900	0.07
	20	20	12000 - 17000	500 - 900	0.04
R1.5	8	8	8000 - 11000	500 - 700	0.17
	10	10	8000 - 11000	500 - 700	0.15
	16	16	8000 - 11000	500 - 700	0.14
	20	20	8000 - 11000	500 - 700	0.12
	25	25	8000 - 11000	500 - 700	0.1
R2.0	10	10	5000 - 8000	400 - 600	0.18
	15	15	5000 - 8000	400 - 600	0.17
	20	20	5000 - 8000	400 - 600	0.16
	25	25	5000 - 8000	400 - 600	0.15
	30	30	5000 - 8000	400 - 600	0.14

EFFICIENCY MILLS

EFA

▶ Long Neck / Square / for **P** **K**

unit: mm



MG

2 Flutes

35°

HRC 55

TiAlN

Finishing
Semi-Finishing

Slotting

Order No.	Diameter D1	Neck Dia D3	Flute Length L1	Effective Length L3	O.A.L. L2	Shank Dia D2
EFA 01006	1.0	0.95	3	6	50	4
EFA 01008	1.0	0.95	3	8	50	4
EFA 01010	1.0	0.95	3	10	50	4
EFA 01012	1.0	0.95	3	12	50	4
EFA 01508	1.5	1.45	4	8	50	4
EFA 01510	1.5	1.45	4	10	50	4
EFA 01512	1.5	1.45	4	12	50	4
EFA 01516	1.5	1.45	4	16	50	4
EFA 02008	2.0	1.92	6	8	50	4
EFA 02010	2.0	1.92	6	10	50	4
EFA 02012	2.0	1.92	6	12	50	4
EFA 02016	2.0	1.92	6	16	50	4
EFA 02020	2.0	1.92	6	20	50	4
EFA 02510	2.5	2.40	8	10	50	4
EFA 02512	2.5	2.40	8	12	50	4
EFA 02516	2.5	2.40	8	16	50	4
EFA 02520	2.5	2.40	8	20	50	4
EFA 03010	3.0	2.90	8	10	50	6
EFA 03012	3.0	2.90	8	12	50	6
EFA 03016	3.0	2.90	8	16	50	6
EFA 03020	3.0	2.90	8	20	75	6
EFA 03025	3.0	2.90	8	25	75	6

▼ Depth of cut

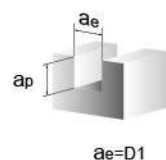

ae=D1

▼ Recommended cutting condition for EFA

MATERIAL	Dia.(D1)	EFFECTIVE LENGTH	Carbon Steels . Alloy Steels	Alloy Steels . Tool Steels	Hardened Steels
			SA5C, FC, FCD, SCM, S50C, SKS...	SCR, SNCM, SKD11, SKD61, NAK80...	SKD11
			SPEED (min ⁻¹)	FEED mm / min	DEPTH OF CUT ap (mm)
1	4	4	25000	1500	0.05
		6	25000	1500	0.03
		10	25000	1500	0.01
1.5	4	4	15000	1200	0.1
		8	15000	1200	0.05
		10	15000	1200	0.025
		12	15000	1200	0.018
2	8	8	12000	900	0.2
		10	8800	700	0.12
		12	7500	600	0.05
		16	7000	500	0.02
3	8	8	8000	600	0.5
		12	8000	600	0.45
		16	5500	450	0.18
		20	4000	300	0.15
4	10	10	6000	400	0.7
		16	6000	400	0.4

HGT

I I.pro

Titanium & Stainless cutting series

I.pro

SBBI

► Ball Nose / for **M** **S**

unit: mm

Order No.	Radius R	Flute Length L1	O.A.L. L2	Shank Dia D2
SBBI 0306	R1.5	6	50	6
SBBI 0406	R2	8	50	6
SBBI 0506	R2.5	10	50	6
SBBI 0606	R3	12	50	6
SBBI 0808	R4	16	60	8
SBBI 1010	R5	20	75	10
SBBI 1212	R6	24	75	12

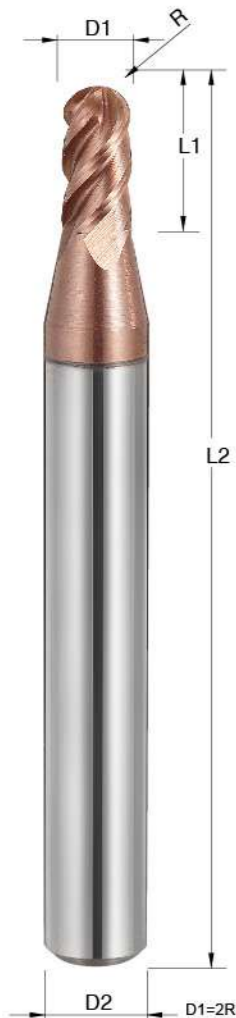
S
MG

4 Flutes

45°

G300

Finishing
Semi-Finishing

Profiling

▼ Depth of cut

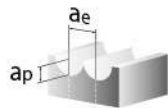

▼ Recommended cutting condition for SBBI

Material	Carbon Steels Alloy Steels/Cast Irons		Pre-Hardened Steels		Stainless Steels		Titanium Alloys		Superalloy	
	SS/S45C/SCM/FC	SKD11/SKD61...	SUS304/SUS316L...	Ti6AL-4V...	Inconel 718...					
Depth of cut	ap:0.25-1.2mm ae:0.75-3mm	ap:0.25-1.2mm ae:0.75-3mm	ap:0.25-1.2mm ae:0.75-3mm	ap:0.25-1.2mm ae:0.75-3mm	ap:0.13-0.6mm ae:0.3-1.2mm					
Radius (R)	SPEED (min ⁻¹)	FEED mm/min	SPEED (min ⁻¹)	FEED mm/min	SPEED (min ⁻¹)	FEED mm/min	SPEED (min ⁻¹)	FEED mm/min	SPEED (min ⁻¹)	FEED mm/min
R1.5	19100	2900	19100	2900	12740	1500	12740	1500	3180	254
R2	14330	2500	14330	2500	9550	1350	9550	1350	2390	191
R2.5	11460	2230	11460	2230	7640	1190	7640	1190	1910	191
R3	9550	1900	9550	1900	6370	1110	6370	1110	1590	160
R4	7160	1700	7160	1700	4780	1090	4780	1090	1190	140
R5	5730	1600	5730	1600	3820	1030	3820	1030	960	135
R6	4780	1590	4780	1590	3190	1020	3190	1020	800	110

I.pro

SEI

► Square / for **M** **S**

unit: mm

Order No.	Diameter D1	Flute Length L1	O.A.L. L2	Shank Dia D2
SEI 0306	3.0	8	50	6
SEI 0406	4.0	11	50	6
SEI 0506	5.0	13	50	6
SEI 0606	6.0	16	50	6
SEI 0808	8.0	20	60	8
SEI 1010	10.0	25	75	10
SEI 1212	12.0	30	75	12
SEI 1616	16.0	40	100	16
SEI 2020	20.0	45	100	20

S
MG

4 Flutes

45°

G300

Finishing
Semi-Finishing

Planing

Side

Slotting

▼ Depth of cut

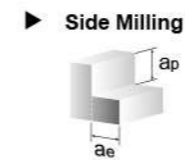

► Slotting

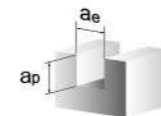

▼ Recommended cutting condition for SEI

Side Milling

MATERIAL	Stainless Steels		Titanium alloy		Inconel 718	
	ap=1D1	ae=0.05D1	ap=1D1	ae=0.05D1	ap=1D1	ae=0.05D1
Depth of cut						
Dia. (D1)	SPEED (min ⁻¹)	FEED mm/min	SPEED (min ⁻¹)	FEED mm/min	SPEED (min ⁻¹)	FEED mm/min
6	4600	590	4600	590	2600	230
8	3500	560	3500	560	2000	220
10	2700	535	2700	535	1600	200
12	2400	520	2400	520	1400	170
16	1700	450	1700	450	1000	130
20	1400	450	1400	450	800	100

Slotting

MATERIAL	Stainless Steels		Titanium alloy		Inconel 718	
	ap=0.5D1	ae=1D1	ap=0.2D1	ae=1D1	ap=0.2D1	ae=1D1
Depth of cut						
Dia. (D1)	SPEED (min ⁻¹)	FEED mm/min	SPEED (min ⁻¹)	FEED mm/min	SPEED (min ⁻¹)	FEED mm/min
6	3000	375	2600	335	1200	105
8	2200	360	2000	320	900	90
10	1800	335	1600	310	750	80
12	1500	330	1300	300	600	70
16	1100	290	1000	250	450	50
20	900	290	800	250	360	40

I.pro

SEPS

► Square / for **M** **S**

unit: mm

Order No.	Diameter D1	Flute Length L1	O.A.L. L2	Shank Dia D2
SEPS 0306	3.0	8	50	6
SEPS 0406	4.0	11	50	6
SEPS 0506	5.0	13	50	6
SEPS 0606	6.0	16	50	6
SEPS 0808	8.0	20	60	8
SEPS 1010	10.0	25	75	10
SEPS 1212	12.0	30	75	12
SEPS 1616	16.0	40	100	16
SEPS 2020	20.0	45	100	20

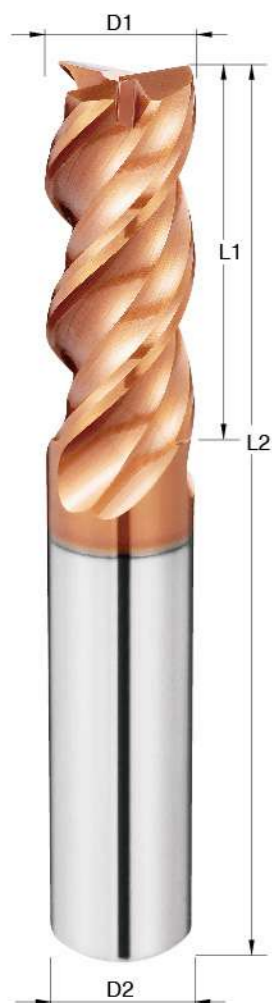
S
MG

3 Flutes

45°

HELICA

Roughing

Finishing
Semi-Finishing

Side

Slotting

▼ Depth of cut

Diameter (D1)	ap(mm)
3	1.5
4	2.0
5	2.5
6	3.0
8	4.0
10	5.0
12	6.0
16	6.0
20	6.0

► Slotting

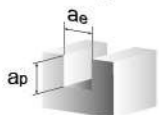

▼ Recommended cutting condition for SEPS

Slotting

Material	Carbon Steels..		Alloy Steels.Tool Steels		Stainless Steels	
	SS/S45C/SCM/FC		SCr.SNCM.SKD11.SKD61.NAK80...		SUS304/SUS316/Ti6AL-4V..	
Dia. (D1)	SPEED (min ⁻¹)	FEED mm/min	SPEED (min ⁻¹)	FEED mm/min	SPEED (min ⁻¹)	FEED mm/min
3	11000	770	9100	400	7700	350
4	8400	1000	6700	500	5600	370
5	7000	1000	5300	500	4500	380
6	5600	1000	4500	540	3700	400
8	4200	900	3400	500	2800	420
10	4000	800	2700	440	2300	470
12	2800	700	2300	400	1900	460
16	2100	600	1700	350	1400	340
20	1800	500	1400	280	1100	270

SEPS

116

www.hgt.com.tw

I.pro

SEPI

► Square / for **M** **S**

unit: mm

Order No.	Diameter D1	Flute Length L1	O.A.L. L2	Shank Dia D2
SEPI 0306	3.0	8	50	6
SEPI 0406	4.0	11	50	6
SEPI 0506	5.0	13	50	6
SEPI 0606	6.0	16	50	6
SEPI 0808	8.0	20	60	8
SEPI 1010	10.0	25	75	10
SEPI 1212	12.0	30	75	12
SEPI 1616	16.0	40	100	16
SEPI 2020	20.0	45	100	20

S
MG

4 Flutes

45°

G300

Roughing

Finishing
Semi-Finishing

Side

Slotting

▼ Depth of cut

► Side Milling

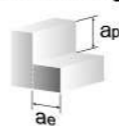

► Slotting

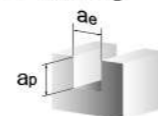

▼ Recommended cutting condition for SEPI

Side Milling

MATERIAL	Stainless Steels		Titanium alloy		Inconel 718	
	ap=1D1	ae=0.05D1	ap=1D1	ae=0.05D1	ap=1D1	ae=0.05D1
Depth of cut						
Dia. (D1)	SPEED (min ⁻¹)	FEED mm / min	SPEED (min ⁻¹)	FEED mm / min	SPEED (min ⁻¹)	FEED mm / min
6	4600	590	4600	590	2600	230
8	3500	560	3500	560	2000	220
10	2700	535	2700	535	1600	200
12	2400	520	2400	520	1400	170
16	1700	450	1700	450	1000	130
20	1400	450	1400	450	800	100

Slotting

MATERIAL	Stainless Steels		Titanium alloy		Inconel 718	
	ap=0.5D1	ae=1D1	ap=0.2D1	ae=1D1	ap=0.2D1	ae=1D1
Depth of cut						
Dia. (D1)	SPEED (min ⁻¹)	FEED mm / min	SPEED (min ⁻¹)	FEED mm / min	SPEED (min ⁻¹)	FEED mm / min
6	3000	375	2600	335	1200	105
8	2200	360	2000	320	900	90
10	1800	335	1600	310	750	80
12	1500	330	1300	300	600	70
16	1100	290	1000	250	450	50
20	900	290	800	250	360	40

SEPI

117

www.hgt.com.tw

I.pro

SIB

► Square / for **M** **S**

unit: mm

Order No.	Diameter D1	Flute Length L1	O.A.L. L2	Shank Dia D2
SIB 0306	3.0	8	50	6
SIB 0406	4.0	11	50	6
SIB 0506	5.0	13	50	6
SIB 0606	6.0	16	50	6
SIB 0808	8.0	20	60	8
SIB 1010	10.0	25	75	10
SIB 1212	12.0	30	75	12
SIB 1616	16.0	40	100	16
SIB 2020	20.0	45	100	20

S
MG

5 Flutes

37°

 $\alpha^\circ \neq \beta^\circ$

G300

Finishing
Semi-Finishing

Planing

Side

Slotting

▼ Recommended cutting condition for SIB

Side Milling

MATERIAL	Stainless Steels		Titanium alloy		Inconel 718	
	ap=1D1	ae=0.05D1	ap=1D1	ae=0.05D1	ap=1D1	ae=0.05D1
Depth of cut						
Dia. (D1)	SPEED (min ⁻¹)	FEED mm/min	SPEED (min ⁻¹)	FEED mm/min	SPEED (min ⁻¹)	FEED mm/min
6	4600	740	4600	740	2600	290
8	3500	700	3500	700	2000	275
10	2700	670	2700	670	1600	250
12	2400	650	2400	650	1400	210
16	1700	560	1700	560	1000	160
20	1400	560	1400	560	800	120

Slotting

MATERIAL	Stainless Steels		Titanium alloy		Inconel 718	
	ap=0.5D1	ae=1D1	ap=0.2D1	ae=1D1	ap=0.2D1	ae=1D1
Depth of cut						
Dia. (D1)	SPEED (min ⁻¹)	FEED mm/min	SPEED (min ⁻¹)	FEED mm/min	SPEED (min ⁻¹)	FEED mm/min
6	3000	470	2600	420	1200	130
8	2200	450	2000	400	900	110
10	1800	420	1600	390	750	100
12	1500	410	1300	370	600	85
16	1100	360	1000	310	450	60
20	900	360	800	310	360	50

▼ Depth of cut

► Side Milling

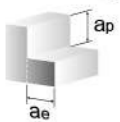

► Slotting

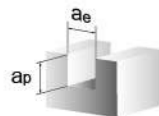

SIB

118

www.hgt.com.tw

I.pro

SHAI

► Square / for **M** **S**

unit: mm

Order No.	Diameter D1	Flute Length L1	O.A.L. L2	Shank Dia D2
SHAI 0606	6.0	16	50	6
SHAI 0808	8.0	20	60	8
SHAI 1010	10.0	25	75	10
SHAI 1212	12.0	30	75	12
SHAI 1616	16.0	40	100	16

S
MG

6 Flutes

45°

G300

Finishing

Side

▼ Depth of cut

► Side Milling

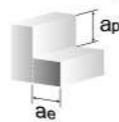

▼ Recommended cutting condition for SHAI

Side Milling

Material	Stainless Steels		Titanium Alloys		Superalloy	
	SUS304/SUS316L..		Ti6AL-4V..		Inconel 718..	
Depth of cut	ap:D1	ae:0.05D1	ap:D1	ae:0.05D1	ap:D1	ae:0.05D1
Dia. (D1)	SPEED (min ⁻¹)	FEED mm/min	SPEED (min ⁻¹)	FEED mm/min	SPEED (min ⁻¹)	FEED mm/min
6	4250	920	3700	800	2100	320
8	3200	900	2800	790	1600	300
10	2550	760	2200	670	1300	260
12	2100	840	1850	740	1100	230
16	1600	740	1400	640	800	180

SHAI

119

www.hgt.com.tw

I.pro

SEGI

► Roughing Square / for **M S** unit: mm

Order No.	Diameter D1	Flute Length L1	O.A.L. L2	Shank Dia D2
SEGI 0606	6.0	16	50	6
SEGI 0808	8.0	20	60	8
SEGI 1010	10.0	25	75	10
SEGI 1212	12.0	30	75	12
SEGI 1616	16.0	40	100	16
SEGI 2020	20.0	45	100	20

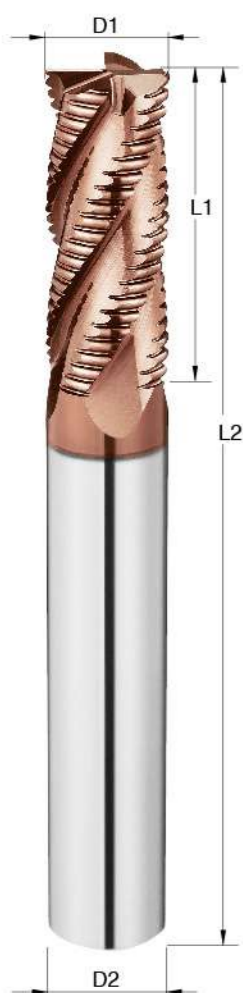
S
MG

4 Flutes

45°

Fine

G300

Roughing

Slotting

Side

I.pro

SRIP

► Corner Radius / for **M S** unit: mm

Order No.	Diameter D1	Corner R R	Flute Length L1	O.A.L. L2	Shank Dia D2
SRIP 0305	3.0	0.5	8	50	6
SRIP 0405	4.0	0.5	11	50	6
SRIP 0605	6.0	0.5	16	50	6
SRIP 0610	6.0	1.0	16	50	6
SRIP 0805	8.0	0.5	20	60	8
SRIP 0810	8.0	1.0	20	60	8
SRIP 1005	10.0	0.5	25	75	10
SRIP 1010	10.0	1.0	25	75	10
SRIP 1205	12.0	0.5	30	75	12
SRIP 1210	12.0	1.0	30	75	12

S
MG

4 Flutes

45°

R

G300

Finishing
Semi-Finishing

Side

Profiling

▼ Recommended cutting condition for SRIP

Side Milling

MATERIAL	Stainless Steels		Titanium alloy		Inconel 718	
	ap=1D1	ae=0.05D1	ap=1D1	ae=0.05D1	ap=1D1	ae=0.05D1
Depth of cut						
Dia. (D1)	SPEED (min ⁻¹)	FEED mm / min	SPEED (min ⁻¹)	FEED mm / min	SPEED (min ⁻¹)	FEED mm / min
6	4600	590	4600	590	2600	230
8	3500	560	3500	560	2000	220
10	2700	535	2700	535	1600	200
12	2400	520	2400	520	1400	170
16	1700	450	1700	450	1000	130
20	1400	450	1400	450	800	100

Slotting

MATERIAL	Stainless Steels		Titanium alloy		Inconel 718	
	ap=0.5D1	ae=1D1	ap=0.2D1	ae=1D1	ap=0.2D1	ae=1D1
Depth of cut						
Dia. (D1)	SPEED (min ⁻¹)	FEED mm / min	SPEED (min ⁻¹)	FEED mm / min	SPEED (min ⁻¹)	FEED mm / min
6	3000	375	2600	335	1200	105
8	2200	360	2000	320	900	90
10	1800	335	1600	310	750	80
12	1500	330	1300	300	600	70
16	1100	290	1000	250	450	50
20	900	290	800	250	360	40

▼ Depth of cut

► Side Milling

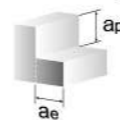

► Slotting

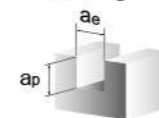

I.pro

SIW

► Square / for **M S**

unit: mm

Order No.	Diameter D1	Flute Length L1	O.A.L. L2	Shank Dia D2
SIW 0306	3.0	8	50	6
SIW 0406	4.0	11	50	6
SIW 0506	5.0	13	50	6
SIW 0606	6.0	16	50	6
SIW 0808	8.0	20	60	8
SIW 1010	10.0	25	75	10
SIW 1212	12.0	30	75	12
SIW 1616	16.0	40	100	16
SIW 2020	20.0	45	100	20

NEW

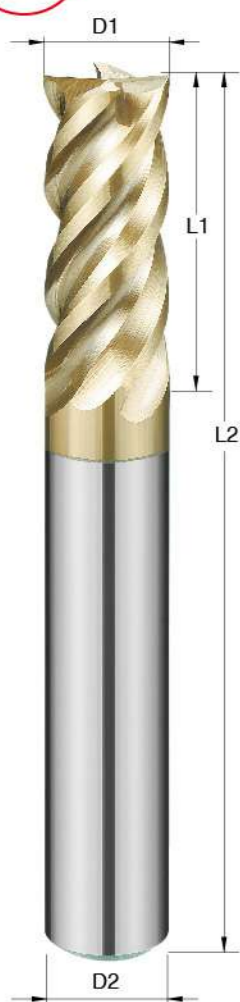

- S MG**
- 4 Flutes
- 40°/43°
- α° ≠ β°
- G-plus
- Planing
- Side
- Slotting

▼ Recommended cutting condition for SIW

Side Milling

Material	Carbon Steels Alloy Steels/Cast Irons		Pre-Hardened Steels		Stainless Steels		Titanium Alloys		Superalloy	
	SS/S45C/SCM/FC	SKD11/SKD61...	SUS304/SUS316L...	Ti6AL-4V...	Inconel 718...					
Depth of cut	ap:1D1 ae:0.2D1	ap:1D1 ae:0.2D1	ap:1D1 ae:0.2D1	ap:1D1 ae:0.1D1	ap:1D1 ae:0.05D1					
Dia. (D1)	SPEED (min ⁻¹)	FEED mm/min	SPEED (min ⁻¹)	FEED mm/min	SPEED (min ⁻¹)	FEED mm/min	SPEED (min ⁻¹)	FEED mm/min	SPEED (min ⁻¹)	FEED mm/min
3	12730	1530	8490	510	6370	440	6370	440	3200	90
4	9550	1530	6370	510	4780	500	4780	500	2400	96
5	7640	1530	5100	510	3820	510	3820	510	1910	96
6	6370	1530	4250	680	3180	510	3180	510	1595	96
8	4780	1530	3180	760	2390	550	2390	550	1195	100
10	3820	1530	2550	710	1910	580	1910	580	955	110
12	3180	1270	2120	590	1590	510	1590	510	800	96
16	2390	1145	1590	510	1190	450	1190	450	600	96
20	1910	1070	1270	460	955	410	955	410	480	96

▼ Depth of cut

► Side Milling



► Slotting

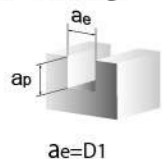

Slotting

Material	Carbon Steels Alloy Steels/Cast Irons		Pre-Hardened Steels		Stainless Steels		Titanium Alloys		Superalloy	
	SS/S45C/SCM/FC	SKD11/SKD61...	SUS304/SUS316L...	Ti6AL-4V...	Inconel 718...					
Depth of cut	ap:1D1	ap:0.5D1	ap:0.5D1	ap:0.1D1	ap:0.05D1					
Dia. (D1)	SPEED (min ⁻¹)	FEED mm/min	SPEED (min ⁻¹)	FEED mm/min	SPEED (min ⁻¹)	FEED mm/min	SPEED (min ⁻¹)	FEED mm/min	SPEED (min ⁻¹)	FEED mm/min
3	11450	590	6660	270	5830	200	5830	200	2880	35
4	8590	680	5040	320	4380	200	4380	200	2160	43
5	6870	750	4050	360	3500	240	3500	240	1720	48
6	5730	840	3330	400	3700	270	3700	270	1440	56
8	4300	820	2520	410	2190	270	2190	270	1080	50
10	3430	850	1980	420	1750	280	1750	280	860	48
12	2860	760	1710	370	1460	250	1460	250	720	46
16	2150	720	1260	340	1095	220	1095	220	540	43
20	1710	680	990	320	875	215	875	215	430	41

SIW

I.pro

SIRW

► Corner Radius / for **M S**

unit: mm

Order No.	Diameter D1	Corner R R	Flute Length L1	O.A.L. L2	Shank Dia D2
SIRW 0305	3.0	0.5	7.5	50	6
SIRW 0405	4.0	0.5	10	50	6
SIRW 0605	6.0	0.5	15	50	6
SIRW 0610	6.0	1	15	50	6
SIRW 0805	8.0	0.5	20	60	8
SIRW 0810	8.0	1	20	60	8
SIRW 1005	10.0	0.5	25	75	10
SIRW 1010	10.0	1	25	75	10
SIRW 1205	12.0	0.5	30	75	12
SIRW 1210	12.0	1	30	75	12

NEW



- S MG**
- 4 Flutes
- 40°/43°
- α° ≠ β°
- G-plus
- Side
- Slotting

▼ Recommended cutting condition for SIRW

Side Milling

Material	Carbon Steels Alloy Steels/Cast Irons		Pre-Hardened Steels		Stainless Steels		Titanium Alloys		Superalloy	
	SS/S45C/SCM/FC	SKD/NAK	SUS304/SUS316L...	Ti6AL-4V...	Inconel 718...					
Depth of cut	ap:1.5D1 ae:0.2D1	ap:1D1 ae:0.05D1	ap:1D1 ae:0.1D1	ap:0.8D1 ae:0.05D1	ap:0.8D1 ae:0.05D1					
Dia. (D1)	SPEED (min ⁻¹)	FEED mm/min	SPEED (min ⁻¹)	FEED mm/min	SPEED (min ⁻¹)	FEED mm/min	SPEED (min ⁻¹)	FEED mm/min	SPEED (min ⁻¹)	FEED mm/min
2	19900	1200	11150	800	10350	415	10350	415	5890	190
3	13270	1330	7430	595	6900	550	6900	550	3930	250
4	9950	1190	5570	670	5180	520	5180	520	2950	240
5	7960	1270	4460	625	4140	500	4140	500	2360	230
6	6630	1460	3710	670	3450	520	3450	520	1960	300
8	4970	1390	2780	700	2590	465	2590	465	1470	280
10	3980	1270	2230	625	2070	480	2070	480	1200	250
12	3320	1260	1860	560	1730	450	1730	450	980	220

▼ Depth of cut

► Side Milling

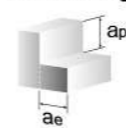

► Slotting

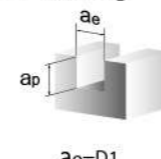

Slotting

Material	Carbon Steels Alloy Steels/Cast Irons		Pre-Hardened Steels		Stainless Steels		Titanium Alloys		Superalloy	
	SS/S45C/SCM/FC	SKD11/SKD61...	SUS304/SUS316L...	Ti6AL-4V...	Inconel 718...					
Depth of cut	ap:0.8D1	ap:0.2D1	ap:0.4D1	ap:0.2D1	ap:0.1D1					
Dia. (D1)	SPEED (min ⁻¹)	FEED mm/min	SPEED (min ⁻¹)	FEED mm/min	SPEED (min ⁻¹)	FEED mm/min	SPEED (min ⁻¹)	FEED mm/min	SPEED (min ⁻¹)	FEED mm/min
2	17500	700	8760	420	9550	230	9550	230	4780	115
3	11670	700	5840	420	6370	230	6370	230	3180	115
4	8750	700	4380	350	4780	215	4780	215	2390	105
5	7000	840	3500	420	3820	230	3820	230	1910	115
6	5840	840	2920	410	3180	240	3180	240	1590	120
8	4380	875	2190	395	2390	215	2390	215	1190	104
10	3500	880	1750	370	1910	230	1910	230	950	115
12	2920	800	1460	350	1590	215	1590	215	800	105

SIRW

D D MILL

Aluminum & Copper cutting series

D MILL

DB

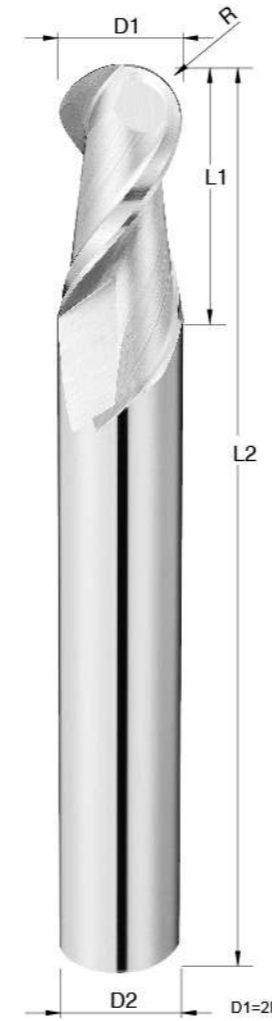

- MG**
- 2 Flutes**
- 45°**
- Finishing**
- Profiling**

► Ball Nose / for **N**

unit: mm

Order No.	Radius R	Flute Length L1	O.A.L. L2	Shank Dia D2
DB 0104	R0.5	3	50	4
DB 0154	R0.75	4	50	4
DB 0204	R1	6	50	4
DB 0303	R1.5	6	50	3
DB 0404	R2	8	50	4
DB 0606	R3	12	50	6
DB 0808	R4	16	60	8
DB 1010	R5	20	75	10
DB 1212	R6	24	75	12

▼ Depth of cut

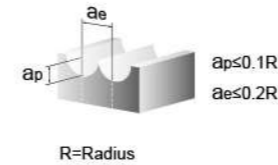

▼ Recommended cutting condition for DB

MATERIAL	Aluminum 1070		Aluminum alloy 2014 / 4032 / 5052 / 6061 / 7075		Aluminum alloy AC85	
	SPEED (min ⁻¹)	FEED mm / min	SPEED (min ⁻¹)	FEED mm / min	SPEED (min ⁻¹)	FEED mm / min
Radius (R)						
R0.5	50000	2300	37000	2000	50000	1400
R0.75	50000	3000	28000	2000	50000	1800
R1	44000	4000	18500	2000	44000	2500
R1.5	28000	4000	11500	2000	28000	2500
R2	22000	4000	8800	2000	22000	2500
R3	16000	4000	6400	2000	16000	2500
R4	12000	4000	4800	2000	12000	2500
R5	10000	4000	4000	2000	10000	2500
R6	8000	4000	3200	2000	8000	2500

D MILL

DEA

► Square / for **N**

unit: mm

Order No.	Diameter D1	Flute Length L1	O.A.L. L2	Shank Dia D2
DEA 0106	1.0	3	50	6
DEA 0206	2.0	6	50	6
DEA 0306	3.0	9	50	6
DEA 0406	4.0	12	50	6
DEA 0506	5.0	15	50	6
DEA 0606	6.0	18	50	6
DEA 0808	8.0	20	60	8
DEA 1010	10.0	30	75	10
DEA 1212	12.0	30	75	12
DEA 1616	16.0	45	100	16

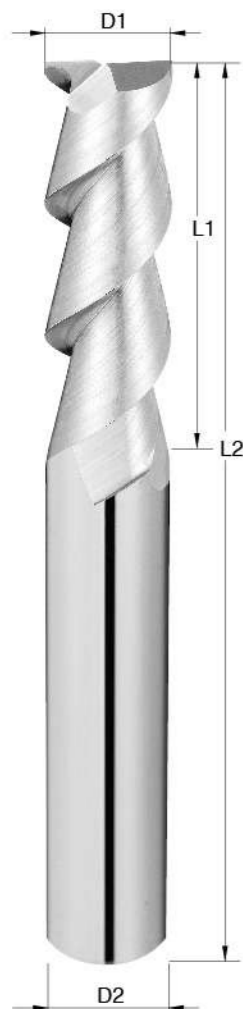

MG

2 Flutes

55°

Finishing

Planing

Slotting

Side

▼ Depth of cut

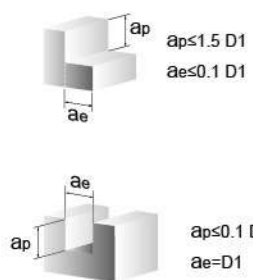

▼ Recommended cutting condition for DEA

MATERIAL	Aluminum 1070		Aluminum alloy 2014 / 4032 / 5052 / 6061 / 7075		Aluminum alloy AC85	
	SPEED (min ⁻¹)	FEED mm / min	SPEED (min ⁻¹)	FEED mm / min	SPEED (min ⁻¹)	FEED mm / min
2	37000	2000(800)	16000	850(350)	20000	1100(450)
3	35000	2000(900)	14000	850(450)	18000	1100(550)
4	26000	2000(1100)	11000	850(550)	13000	1100(660)
5	21000	2000(1100)	9000	850(550)	10000	1100(660)
6	17000	2000(1100)	7000	850(550)	9000	1100(660)
8	13000	2000(1100)	5500	850(650)	7000	1100(800)
10	11000	2000(1300)	4400	850(650)	5500	1100(800)
12	8800	2000(1300)	3600	850(800)	4500	1100(800)
16	6500	2000(1100)	3000	850(550)	3500	1100(900)

(): Grooving

D MILL

DEB

► Square / for **N**

unit: mm

Order No.	Diameter D1	Flute Length L1	O.A.L. L2	Shank Dia D2
DEB 0106	1.0	3	50	6
DEB 0206	2.0	6	50	6
DEB 0306	3.0	9	50	6
DEB 0406	4.0	12	50	6
DEB 0506	5.0	15	50	6
DEB 0606	6.0	18	50	6
DEB 0808	8.0	20	60	8
DEB 1010	10.0	30	75	10
DEB 1212	12.0	30	75	12
DEB 1616	16.0	45	100	16

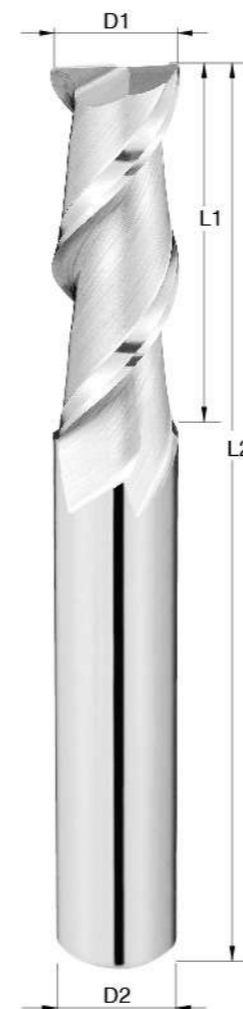

MG

2 Flutes

45°

Finishing

Planing

Slotting

Side

▼ Depth of cut

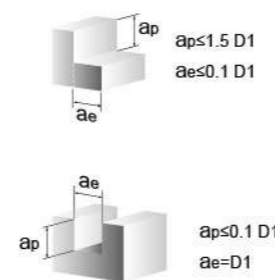

▼ Recommended cutting condition for DEB

MATERIAL	Aluminum 1070		Aluminum alloy 2014 / 4032 / 5052 / 6061 / 7075		Aluminum alloy AC85	
	SPEED (min ⁻¹)	FEED mm / min	SPEED (min ⁻¹)	FEED mm / min	SPEED (min ⁻¹)	FEED mm / min
2	37000	2000(800)	16000	850(350)	20000	1100(450)
3	35000	2000(900)	14000	850(450)	18000	1100(550)
4	26000	2000(1100)	11000	850(550)	13000	1100(660)
5	21000	2000(1100)	9000	850(550)	10000	1100(660)
6	17000	2000(1100)	7000	850(550)	9000	1100(660)
8	13000	2000(1100)	5500	850(650)	7000	1100(800)
10	11000	2000(1300)	4400	850(650)	5500	1100(800)
12	8800	2000(1300)	3600	850(800)	4500	1100(800)
16	6500	2000(1100)	3000	850(550)	3500	1100(900)

(): Grooving

D MILL

DEC

► Square / for **N**

unit: mm

Order No.	Diameter D1	Flute Length L1	O.A.L. L2	Shank Dia D2
DEC 0206	2.0	6	50	6
DEC 0306	3.0	9	50	6
DEC 0406	4.0	12	50	6
DEC 0506	5.0	15	50	6
DEC 0606	6.0	18	50	6
DEC 0808	8.0	20	60	8
DEC 1010	10.0	30	75	10
DEC 1212	12.0	30	75	12
DEC 1616	16.0	45	100	16
DEC 2020	20.0	45	100	20

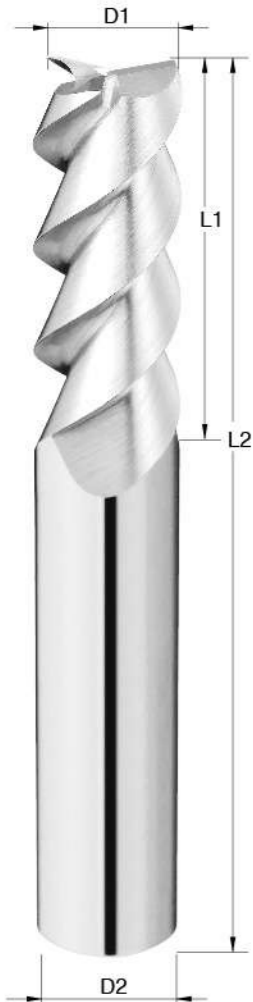

- MG**
- 3 Flutes
- 55°
- Finishing
- Planing
- Slotting
- Side

▼ Depth of cut

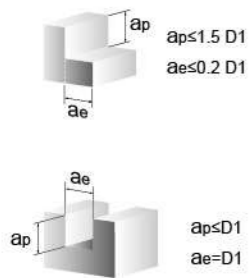

▼ Recommended cutting condition for DEC

MATERIAL	Aluminum 1070		Aluminum alloy 2014 / 4032 / 5052 / 6061 / 7075		Aluminum alloy AC85	
	SPEED (min ⁻¹)	FEED mm / min	SPEED (min ⁻¹)	FEED mm / min	SPEED (min ⁻¹)	FEED mm / min
2	37000	2400(950)	16000	1000(380)	20000	1300(500)
3	35000	2400(1050)	14000	1000(500)	18000	1300(600)
4	26000	2400(1200)	11000	1000(600)	13000	1300(720)
5	21000	2400(1200)	9000	1000(600)	10000	1300(720)
6	17000	2400(1200)	7000	1000(600)	9000	1300(720)
8	13000	2400(1200)	5500	1000(700)	7000	1300(880)
10	11000	2400(1400)	4400	1000(700)	5500	1300(880)
12	8800	2400(1400)	3600	1000(880)	4500	1300(880)
16	6500	2400(1200)	3000	1000(600)	3500	1300(1000)
20	5300	2400(1200)	2200	1000(600)	2500	1300(700)

() : Grooving

D MILL

DED

► Square / for **N**

unit: mm

Order No.	Diameter D1	Flute Length L1	O.A.L. L2	Shank Dia D2
DED 0206	2.0	6	50	6
DED 0306	3.0	9	50	6
DED 0406	4.0	12	50	6
DED 0506	5.0	15	50	6
DED 0606	6.0	18	50	6
DED 0808	8.0	20	60	8
DED 1010	10.0	30	75	10
DED 1212	12.0	30	75	12
DED 1616	16.0	45	100	16
DED 2020	20.0	45	100	20

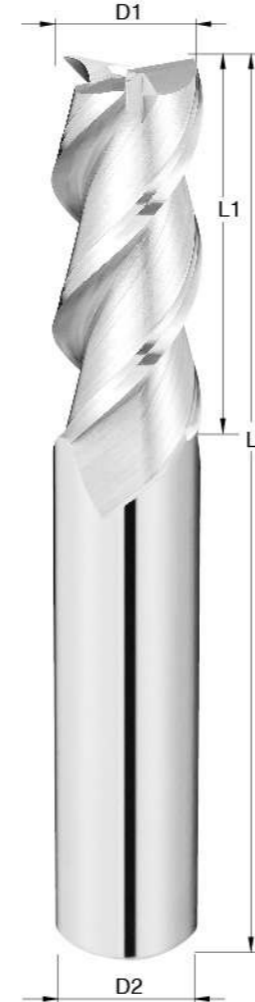

- MG**
- 3 Flutes
- 45°
- Finishing
- Planing
- Slotting
- Side

▼ Depth of cut

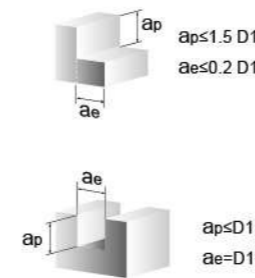

▼ Recommended cutting condition for DED

MATERIAL	Aluminum 1070		Aluminum alloy 2014 / 4032 / 5052 / 6061 / 7075		Aluminum alloy AC85	
	SPEED (min ⁻¹)	FEED mm / min	SPEED (min ⁻¹)	FEED mm / min	SPEED (min ⁻¹)	FEED mm / min
2	37000	2400(950)	16000	1000(380)	20000	1300(500)
3	35000	2400(1050)	14000	1000(500)	18000	1300(600)
4	26000	2400(1200)	11000	1000(600)	13000	1300(720)
5	21000	2400(1200)	9000	1000(600)	10000	1300(720)
6	17000	2400(1200)	7000	1000(600)	9000	1300(720)
8	13000	2400(1200)	5500	1000(700)	7000	1300(880)
10	11000	2400(1400)	4400	1000(700)	5500	1300(880)
12	8800	2400(1400)	3600	1000(880)	4500	1300(880)
16	6500	2400(1200)	3000	1000(600)	3500	1300(1000)
20	5300	2400(1200)	2200	1000(600)	2500	1300(700)

() : Grooving

D MILL

DEDP

► Square / for **N**

unit: mm

Order No.	Diameter D1	Flute Length L1	O.A.L. L2	Shank Dia D2
DEDP 0206	2.0	6	50	6
DEDP 0306	3.0	9	50	6
DEDP 0406	4.0	12	50	6
DEDP 0506	5.0	15	50	6
DEDP 0606	6.0	18	50	6
DEDP 0808	8.0	20	60	8
DEDP 1010	10.0	30	75	10
DEDP 1212	12.0	30	75	12
DEDP 1616	16.0	45	100	16
DEDP 2020	20.0	45	100	20



MG

3 Flutes

45°

DLC

Finishing

Planing

Slotting

Side

▼ Depth of cut

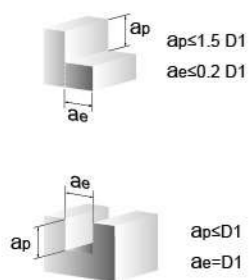

▼ Recommended cutting condition for DEDP

MATERIAL	Aluminum 1070		Aluminum alloy 2014 / 4032 / 5052 / 6061 / 7075		Aluminum alloy AC85	
	SPEED (min ⁻¹)	FEED mm / min	SPEED (min ⁻¹)	FEED mm / min	SPEED (min ⁻¹)	FEED mm / min
2	37000	2400(950)	16000	1000(380)	20000	1300(500)
3	35000	2400(1050)	14000	1000(500)	18000	1300(600)
4	26000	2400(1200)	11000	1000(600)	13000	1300(720)
5	21000	2400(1200)	9000	1000(600)	10000	1300(720)
6	17000	2400(1200)	7000	1000(600)	9000	1300(720)
8	13000	2400(1200)	5500	1000(700)	7000	1300(880)
10	11000	2400(1400)	4400	1000(700)	5500	1300(880)
12	8800	2400(1400)	3600	1000(880)	4500	1300(880)
16	6500	2400(1200)	3000	1000(600)	3500	1300(1000)
20	5300	2400(1200)	2200	1000(600)	2500	1300(700)

(): Grooving

D MILL

DEL

► Long Flute / Square / for **N**

unit: mm

Order No.	Diameter D1	Flute Length L1	O.A.L. L2	Shank Dia D2
DEL 0206	2.0	9	75	6
DEL 0306	3.0	12	75	6
DEL 0406	4.0	16	75	6
DEL 0506	5.0	20	75	6
DEL 0606	6.0	25	75	6
DEL 0808	8.0	32	75	8
DEL 1010	10.0	50	100	10
DEL 1212	12.0	50	100	12
DEL 1616	16.0	65	150	16
DEL 2020	20.0	75	150	20

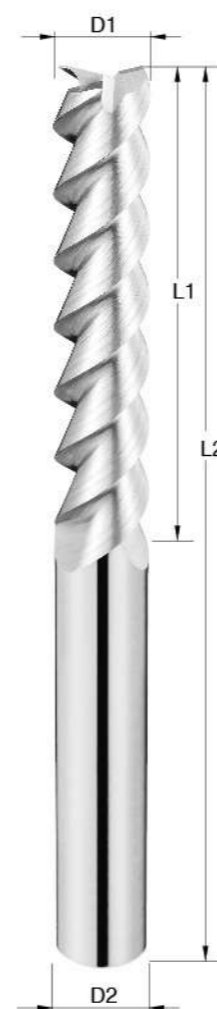

MG

3 Flutes

55°

Finishing

Planing

Slotting

Side

▼ Depth of cut

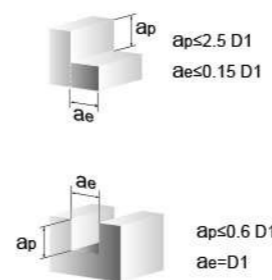

▼ Recommended cutting condition for DEL

MATERIAL	Aluminum 1070		Aluminum alloy 2014 / 4032 / 5052 / 6061 / 7075		Aluminum alloy AC85	
	SPEED (min ⁻¹)	FEED mm / min	SPEED (min ⁻¹)	FEED mm / min	SPEED (min ⁻¹)	FEED mm / min
2	30000	600(500)	15000	250(250)	18000	300(300)
3	26000	600(500)	11000	250(250)	13500	300(350)
4	20000	600(550)	8500	250(250)	10000	300(350)
5	15600	600(550)	6700	250(200)	8000	300(350)
6	13500	600(550)	5500	250(200)	6700	300(350)
8	10000	600(600)	4200	250(200)	5000	300(350)
10	7500	600(600)	3300	250(200)	4000	300(350)
12	6700	600(600)	2700	250(200)	3400	300(350)
16	5000	600(500)	2300	250(200)	2500	300(350)
20	4000	600(500)	1700	250(200)	2000	300(350)

(): Grooving

D MILL

DEPW

► Square / for **N**

unit: mm

Order No.	Diameter D1	Flute Length L1	O.A.L. L2	Shank Dia D2
DEPW 0306	3.0	8	50	6
DEPW 0406	4.0	11	50	6
DEPW 0506	5.0	13	50	6
DEPW 0606	6.0	16	50	6
DEPW 0808	8.0	20	65	8
DEPW 1010	10.0	25	80	10
DEPW 1212	12.0	30	80	12
DEPW 1616	16.0	50	110	16
DEPW 2020	20.0	60	150	20

NEW

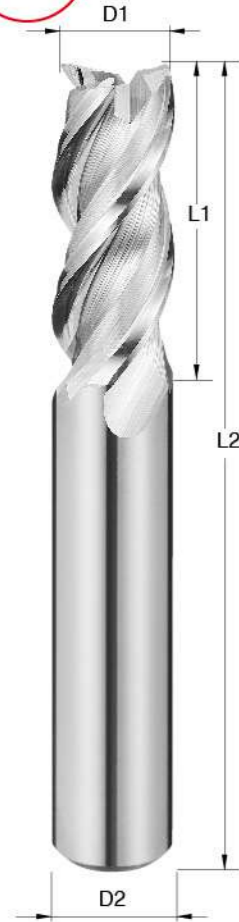

- SMG**
- 3 Flutes
- 38°/40°/41°
- Planing
- Slotting
- Side

▼ Recommended cutting condition for DEPW

Side Milling

Material	Aluminums		Aluminum Alloys		Aluminum Alloy Castings	
	A1050/A1070		A2017/A5052/A7075		AC/ADC	
Depth of cut	ap:1.5D1 ae:0.3D1		ap:1.5D1 ae:0.3D1		ap:1.5D1 ae:0.3D1	
Dia. (D1)	SPEED (min ⁻¹)	FEED mm/min	SPEED (min ⁻¹)	FEED mm/min	SPEED (min ⁻¹)	FEED mm/min
3	20000	3600	20000	3000	20000	3600
4	20000	3600	20000	3000	19900	3600
5	20000	3600	17200	3000	15920	3600
6	15920	3340	14330	3000	13270	2790
8	11940	2860	10750	2580	9950	2380
10	9550	2580	8600	2400	7960	2150
12	7960	2390	7160	2150	6630	1990

Slotting

Material	Aluminums		Aluminum Alloys		Aluminum Alloy Castings	
	A1050/A1070		A2017/A5052/A7075		AC/ADC	
Depth of cut	ap:1.0D1 ae:0.3D1		ap:1.0D1 ae:0.3D1		ap:1.0D1 ae:0.3D1	
Dia. (D1)	SPEED (min ⁻¹)	FEED mm/min	SPEED (min ⁻¹)	FEED mm/min	SPEED (min ⁻¹)	FEED mm/min
3	18000	2700	19100	2700	14860	2700
4	15920	2300	15920	2300	11140	2300
5	12740	2300	14000	2000	8920	1600
6	10620	1910	11670	1750	7430	1330
8	7960	1910	8750	1750	5570	1330
10	6370	1720	7000	1680	4460	1200
12	5300	1590	5840	1570	3710	1110

▼ Depth of cut

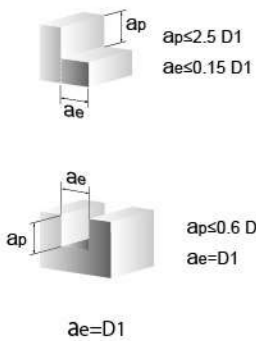

D MILL

DEG

► Roughing / Square / for **N**

unit: mm

Order No.	Diameter D1	Neck Dia D3	Flute Length L1	Effective Length L3	O.A.L. L2	Shank Dia D2
DEG 0606	6.0	5.80	12	18	50	6
DEG 0808	8.0	7.70	16	24	60	8
DEG 1010	10.0	9.60	20	30	75	10
DEG 1212	12.0	11.50	24	36	75	12
DEG 1616	16.0	15.40	32	45	100	16

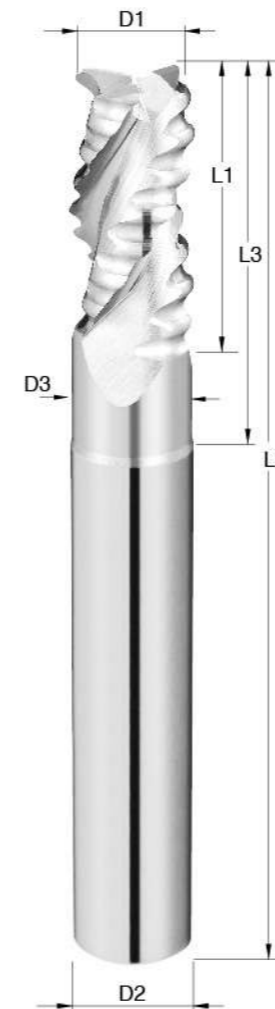

- MG**
- 3 Flutes
- Rough
- 38°
- Roughing
- Semi-Finishing
- Slotting
- Side

▼ Recommended cutting condition for DEG

Side Milling

Material	Aluminum Alloys		Aluminum Alloy Castings	
	A2017/A5052/A7075		AC/ADC	
Depth of cut	ap:1D1 ae:0.5D1		ap:1D1 ae:0.5D1	
Dia. (D1)	SPEED (min ⁻¹)	FEED mm/min	SPEED (min ⁻¹)	FEED mm/min
6	32000	9200	16000	3700
8	24000	9000	12000	3600
10	18000	8200	9000	3200
12	15000	7800	7600	3000
16	11500	7200	5700	2900

Slotting

Material	Aluminum Alloys		Aluminum Alloy Castings	
	A2017/A5052/A7075		AC/ADC	
Depth of cut	ap:1D1		ap:1D1	
Dia. (D1)	SPEED (min ⁻¹)	FEED mm/min	SPEED (min ⁻¹)	FEED mm/min
6	32000	7400	16000	3000
8	24000	7200	12000	2900
10	18000	6500	9000	2600
12	15000	6200	7600	2500
16	11500	5800	5700	2300

▼ Depth of cut

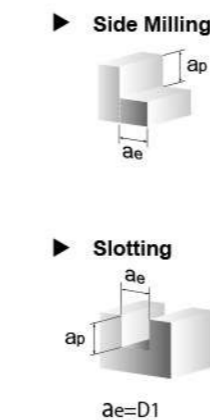

D MILL

DFR

► Square / for **N**

unit: mm

Order No.	Diameter D1	Flute Length L1	O.A.L. L2	Shank Dia D2
DFR 0606	6.0	16	50	6
DFR 0808	8.0	20	60	8
DFR 1010	10.0	25	75	10
DFR 1212	12.0	30	75	12
DFR 1616	16.0	40	100	16
DFR 2020	20.0	45	100	20



- S**
MG
- 3 Flutes
- 45°
- Roughing
- Semi-Finishing
- Planing
- Slotting
- Side

D MILL

DRC

► Corner Radius / for **N**

unit: mm

Order No.	Diameter D1	Corner R R	Neck Dia D3	Flute Length L1	Effective Length L3	O.A.L. L2	Shank Dia D2
DRC 0305	3.0	0.5	2.90	6	9	50	6
DRC 0405	4.0	0.5	3.88	8	12	50	6
DRC 0605	6.0	0.5	5.80	12	18	50	6
DRC 0610	6.0	1.0	5.80	12	18	50	6
DRC 0805	8.0	0.5	7.70	16	24	60	8
DRC 0810	8.0	1.0	7.70	16	24	60	8
DRC 1002	10.0	0.2	9.60	20	30	75	10
DRC 1005	10.0	0.5	9.60	20	30	75	10
DRC 1010	10.0	1.0	9.60	20	30	75	10
DRC 1202	12.0	0.2	11.50	24	36	75	12
DRC 1205	12.0	0.5	11.50	24	36	75	12
DRC 1210	12.0	1.0	11.50	24	36	75	12
DRC 1603	16.0	0.3	15.40	30	40	100	16
DRC 1605	16.0	0.5	15.40	30	40	100	16
DRC 1610	16.0	1.0	15.40	30	40	100	16
DRC 1630	16.0	3.0	15.40	30	40	100	16

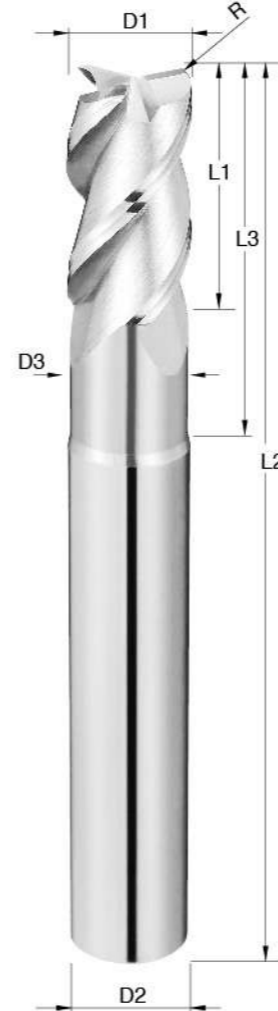

- S**
MG
- 3 Flutes
- 45°
- R
- Finishing
- Semi-Finishing
- Profiling

▼ Depth of cut

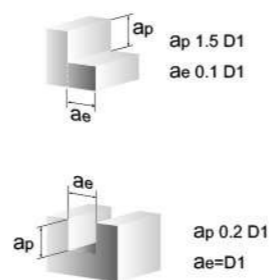

▼ Recommended cutting condition for DRC

MATERIAL	Aluminum 1070		Aluminum alloy 2014 / 4032 / 5052 / 6061 / 7075		Aluminum alloy AC85		
	Dia. (D1)	SPEED (min ⁻¹)	FEED mm / min	SPEED (min ⁻¹)	FEED mm / min	SPEED (min ⁻¹)	FEED mm / min
Side Milling	3	25000	1000	25000	1000	9000	350
	4	18000	1200	18000	1200	7000	400
	5	15000	1300	15000	1300	6000	450
	6	12000	1400	12000	1400	5000	500
	8	9000	1500	9000	1500	4000	550
	10	7000	1800	7000	1800	3000	600
Grooving	12	6000	1900	6000	1900	2500	650
	16	4500	1900	4500	1900	1500	650
	3	25000	800	25000	800	9000	350
	4	18000	800	18000	800	7000	400
	5	15000	900	15000	900	6000	450
	6	12000	1000	12000	1000	5000	500
8	9000	1000	9000	1000	4000	550	
10	7000	1200	7000	1200	3000	600	
12	6000	1300	6000	1300	2500	650	
16	4500	1300	4500	1300	1500	650	

D MILL

DBX

▶ Ball Nose / for **N**

unit: mm

Order No.	Radius R	Flute Length L1	O.A.L. L2	Shank Dia D2
DBX 0104	R0.5	3	50	4
DBX 0154	R0.75	4	50	4
DBX 0204	R1	6	50	4
DBX 0303	R1.5	6	50	3
DBX 0404	R2	8	50	4
DBX 0606	R3	12	50	6
DBX 0808	R4	16	60	8
DBX 1010	R5	20	75	10
DBX 1212	R6	24	75	12

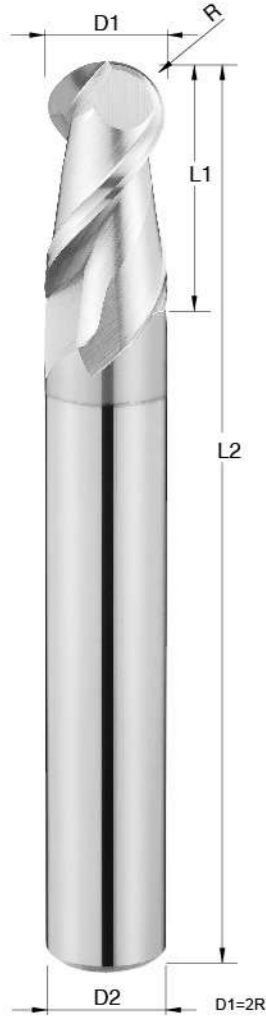

MG

2 Flutes

45°

CRN

Finishing

Profiling

▼ Depth of cut

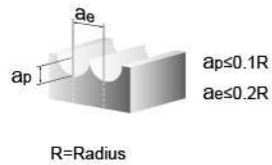

▼ Recommended cutting condition for DBX

MATERIAL	Aluminum 1070		Aluminum alloy 2014 / 4032 / 5052 / 6061 / 7075		Aluminum alloy AC85	
	SPEED (min ⁻¹)	FEED mm / min	SPEED (min ⁻¹)	FEED mm / min	SPEED (min ⁻¹)	FEED mm / min
R0.5	50000	2300	37000	2000	50000	1400
R0.75	50000	3000	28000	2000	50000	1800
R1	44000	4000	18500	2000	44000	2500
R1.5	28000	4000	11500	2000	28000	2500
R2	22000	4000	8800	2000	22000	2500
R3	16000	4000	6400	2000	16000	2500
R4	12000	4000	4800	2000	12000	2500
R5	10000	4000	4000	2000	10000	2500
R6	8000	4000	3200	2000	8000	2500

D MILL

DEDX

▶ Square / for **N**

unit: mm

Order No.	Diameter D1	Flute Length L1	O.A.L. L2	Shank Dia D2
DEDX 0206	2.0	6	50	6
DEDX 0306	3.0	9	50	6
DEDX 0406	4.0	12	50	6
DEDX 0506	5.0	15	50	6
DEDX 0606	6.0	18	50	6
DEDX 0808	8.0	20	60	8
DEDX 1010	10.0	30	75	10
DEDX 1212	12.0	30	75	12
DEDX 1616	16.0	45	100	16
DEDX 2020	20.0	45	100	20



MG

3 Flutes

45°

CRN

Finishing

Planing

Slotting

Side

▼ Depth of cut

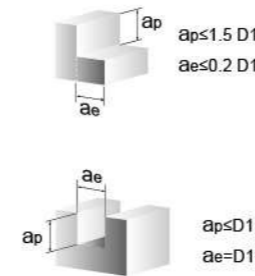

▼ Recommended cutting condition for DEDX

MATERIAL	Aluminum 1070		Aluminum alloy 2014 / 4032 / 5052 / 6061 / 7075		Aluminum alloy AC85	
	SPEED (min ⁻¹)	FEED mm / min	SPEED (min ⁻¹)	FEED mm / min	SPEED (min ⁻¹)	FEED mm / min
2	37000	2400(950)	16000	1000(380)	20000	1300(500)
3	35000	2400(1050)	14000	1000(500)	18000	1300(600)
4	26000	2400(1200)	11000	1000(600)	13000	1300(720)
5	21000	2400(1200)	9000	1000(600)	10000	1300(720)
6	17000	2400(1200)	7000	1000(600)	9000	1300(720)
8	13000	2400(1200)	5500	1000(700)	7000	1300(880)
10	11000	2400(1400)	4400	1000(700)	5500	1300(880)
12	8800	2400(1400)	3600	1000(880)	4500	1300(880)
16	6500	2400(1200)	3000	1000(600)	3500	1300(1000)
20	5300	2400(1200)	2200	1000(600)	2500	1300(700)

G **G.pro**

Graphite cutting series

G.pro

SGBB

► Ball Nose / for **N**

unit: mm

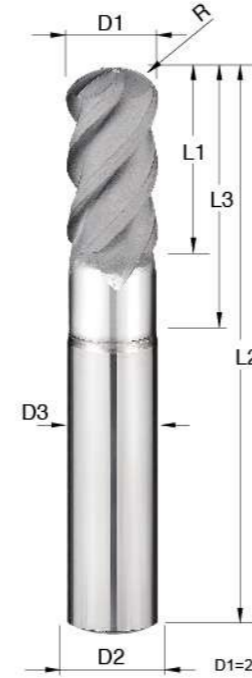

Order No.	Radius R	Neck Dia D3	Flute Length L1	Effective Length L3	O.A.L. L2	Shank Dia D2
SGBB 0404	R2	3.88	4	8	50	4
SGBB 0606	R3	5.80	6	12	50	6
SGBB 0808	R4	7.70	8	16	60	8
SGBB 1010	R5	9.60	10	20	75	10
SGBB 1212	R6	11.50	12	20	75	12

G.pro

SGBF

► Ball Nose / for **N**

unit: mm

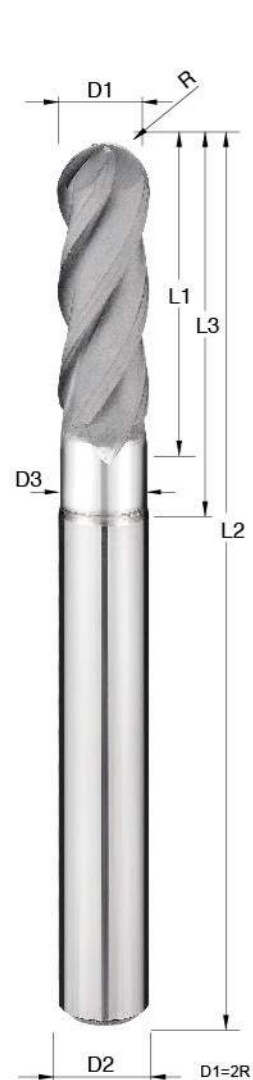

Order No.	Radius R	Neck Dia D3	Flute Length L1	Effective Length L3	O.A.L. L2	Shank Dia D2
SGBF 0404	R2	3.88	20	25	75	4
SGBF 0404A	R2	3.88	20	25	100	4
SGBF 0606	R3	5.80	25	30	75	6
SGBF 0606A	R3	5.80	25	30	100	6
SGBF 0606B	R3	5.80	25	30	150	6
SGBF 0808	R4	7.70	30	40	100	8
SGBF 0808B	R4	7.70	30	40	150	8
SGBF 1010	R5	9.60	30	40	100	10
SGBF 1010B	R5	9.60	30	40	150	10
SGBF 1212	R6	11.50	30	40	100	12
SGBF 1212B	R6	11.50	30	40	150	12

SGBF

140

www.hgt.com.tw

G.pro

SGEB

► Square / for **N**

unit: mm

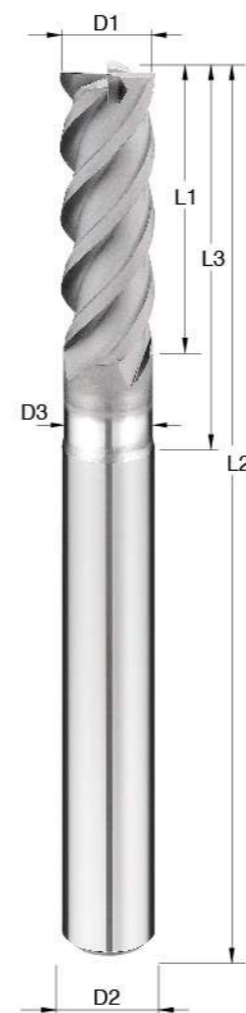

Order No.	Diameter D1	Neck Dia D3	Flute Length L1	Effective Length L3	O.A.L. L2	Shank Dia D2
SGEB 0404	4.0	3.88	20	25	75	4
SGEB 0404A	4.0	3.88	20	25	100	4
SGEB 0606	6.0	5.80	25	30	75	6
SGEB 0606A	6.0	5.80	25	30	100	6
SGEB 0606B	6.0	5.80	25	30	150	6
SGEB 0808	8.0	7.70	30	40	100	8
SGEB 0808B	8.0	7.70	30	40	150	8
SGEB 1010	10.0	9.60	30	40	100	10
SGEB 1010B	10.0	9.60	30	40	150	10
SGEB 1212	12.0	11.50	30	40	100	12
SGEB 1212B	12.0	11.50	30	40	150	12

SGEB

141

www.hgt.com.tw

G.pro

SGRD

▶ Corner Radius / for **N**

unit: mm

Order No.	Diameter D1	Corner R R	Neck Dia D3	Flute Length L1	Effective Length L3	O.A.L L2	Shank Dia D2
SGRD 0403	4.0	0.3	3.88	4	8	50	4
SGRD 0405	4.0	0.5	3.88	4	8	50	4
SGRD 0603	6.0	0.3	5.80	6	12	50	6
SGRD 0605	6.0	0.5	5.80	6	12	50	6
SGRD 0805	8.0	0.5	7.70	8	16	60	8
SGRD 1010	10.0	1.0	9.60	10	20	75	10
SGRD 1210	12.0	1.0	11.50	12	20	75	12

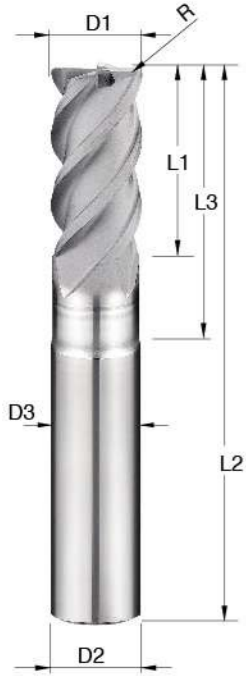

G.pro

SGRB

▶ Corner Radius / for **N**

unit: mm

Order No.	Diameter D1	Corner R R	Neck Dia D3	Flute Length L1	Effective Length L3	O.A.L L2	Shank Dia D2
SGRB 0403	4.0	0.3	3.88	20	25	75	4
SGRB 0403A	4.0	0.3	3.88	20	25	100	4
SGRB 0405	4.0	0.5	3.88	20	25	75	4
SGRB 0405A	4.0	0.5	3.88	20	25	100	4
SGRB 0603	6.0	0.3	5.80	25	30	75	6
SGRB 0603A	6.0	0.3	5.80	25	30	100	6
SGRB 0605	6.0	0.5	5.80	25	30	75	6
SGRB 0605A	6.0	0.5	5.80	25	30	100	6
SGRB 0605B	6.0	0.5	5.80	25	30	150	6
SGRB 0805	8.0	0.5	7.70	30	40	100	8
SGRB 0805B	8.0	0.5	7.70	30	40	150	8
SGRB 1010	10.0	1.0	9.60	30	40	100	10
SGRB 1010B	10.0	1.0	9.60	30	40	150	10
SGRB 1210	12.0	1.0	11.50	30	40	100	12
SGRB 1210B	12.0	1.0	11.50	30	40	150	12

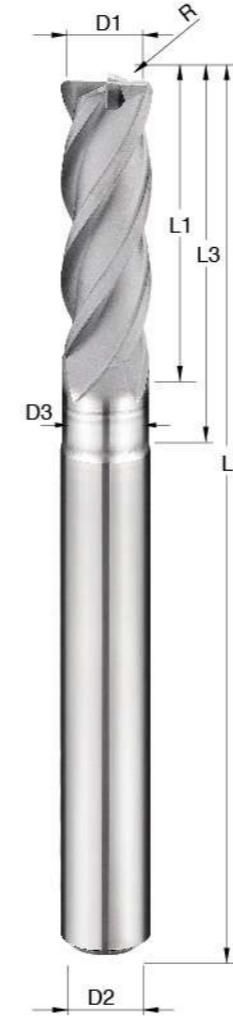

G.pro

SGBS

► Long Neck / Ball Nose / for **N**

unit: mm



Order No.	Radius R	Neck Dia D3	Flute Length L1	Effective Length L3	O.A.L. L2	Shank Dia D2
SGBS 01006	R0.5	0.95	1.5	6	50	4
SGBS 01008	R0.5	0.95	1.5	8	50	4
SGBS 01010	R0.5	0.95	1.5	10	50	4
SGBS 01012	R0.5	0.95	1.5	12	50	4
SGBS 01508	R0.75	1.45	2	8	50	4
SGBS 01510	R0.75	1.45	2	10	50	4
SGBS 01512	R0.75	1.45	2	12	50	4
SGBS 01516	R0.75	1.45	2	16	50	4
SGBS 01520	R0.75	1.45	2	20	50	4
SGBS 02008	R1	1.92	3	8	50	4
SGBS 02010	R1	1.92	3	10	50	4
SGBS 02012	R1	1.92	3	12	50	4
SGBS 02016	R1	1.92	3	16	50	4
SGBS 02020	R1	1.92	3	20	50	4
SGBS 03016	R1.5	2.90	4	16	50	4
SGBS 03025	R1.5	2.90	4	25	75	4
SGBS 04020	R2	3.88	5	20	50	4
SGBS 04030	R2	3.88	5	30	75	4

G.pro

SGES

► Long Neck / Square / for **N**

unit: mm



Order No.	Diameter D1	Neck Dia D3	Flute Length L1	Effective Length L3	O.A.L. L2	Shank Dia D2
SGES 01006	1.0	0.95	1.5	6	50	4
SGES 01008	1.0	0.95	1.5	8	50	4
SGES 01010	1.0	0.95	1.5	10	50	4
SGES 01510	1.5	1.45	2	10	50	4
SGES 01512	1.5	1.45	2	12	50	4
SGES 01516	1.5	1.45	2	16	50	4
SGES 02010	2.0	1.92	3	10	50	4
SGES 02012	2.0	1.92	3	12	50	4
SGES 02016	2.0	1.92	3	16	50	4
SGES 02020	2.0	1.92	3	20	50	4
SGES 03016	3.0	2.90	4	16	50	4
SGES 03020	3.0	2.90	4	20	50	4
SGES 03025	3.0	2.90	4	25	75	4
SGES 04020	4.0	3.88	5	20	50	4
SGES 04030	4.0	3.88	5	30	75	4

G.pro

SGRS

► Long Neck / Corner Radius / for **N**

unit: mm



Order No.	Diameter D1	Corner R R	Neck Dia D3	Flute Length L1	Effective Length L3	O.A.L. L2	Shank Dia D2	Flutes
SGRS 01008	1.0	0.2	0.95	1.0	8	50	4	2
SGRS 01010	1.0	0.2	0.95	1.0	10	50	4	2
SGRS 01012	1.0	0.2	0.95	1.0	12	50	4	2
SGRS 01016	1.0	0.2	0.95	1.0	16	50	4	2
SGRS 01020	1.0	0.2	0.95	1.0	20	50	4	2
SGRS 01508	1.5	0.2	1.45	1.5	8	50	4	2
SGRS 01510	1.5	0.2	1.45	1.5	10	50	4	2
SGRS 01512	1.5	0.2	1.45	1.5	12	50	4	2
SGRS 01516	1.5	0.2	1.45	1.5	16	50	4	2
SGRS 01520	1.5	0.2	1.45	1.5	20	50	4	2
SGRS 02010	2.0	0.2	1.92	2.0	10	50	4	4
SGRS 02012	2.0	0.2	1.92	2.0	12	50	4	4
SGRS 02016	2.0	0.2	1.92	2.0	16	50	4	4
SGRS 02020	2.0	0.2	1.92	2.0	20	50	4	4
SGRS 03020	3.0	0.2	2.90	3.0	20	50	4	4
SGRS 03025	3.0	0.2	2.90	3.0	25	75	4	4
SGRS 030201	3.0	0.5	2.90	3.0	20	50	4	4
SGRS 030251	3.0	0.5	2.90	3.0	25	75	4	4
SGRS 04020	4.0	0.2	3.88	4.0	20	50	4	4
SGRS 04030	4.0	0.2	3.88	4.0	30	75	4	4
SGRS 040201	4.0	0.5	3.88	4.0	20	50	4	4
SGRS 040301	4.0	0.5	3.88	4.0	30	75	4	4

HGT

DT **DEN.pro**

Dental end mills

DEN.pro

TOBF

▶ Long Neck / Ball Nose / for ZrO₂

unit: mm



Order No.	Radius R	Neck Dia D3	Flute Length L1	Effective Length L3	O.A.L. L2	Shank Dia D2
TOBF 00610.3	R0.3	0.56	2.5	10	50	3
TOBF 00812.3	R0.4	0.76	3.0	12	50	3
TOBF 01016.3	R0.5	0.95	4.0	16	50	3
TOBF 01018.3	R0.5	0.95	4.0	18	50	3
TOBF 01518.3	R0.75	1.45	4.0	18	50	3
TOBF 02020.3	R1	1.92	4.5	20	50	3
TOBF 02025.3	R1	1.92	4.5	25	50	3
TOBF 02522.3	R1.25	2.40	4.5	22	50	3
TOBF 02525.3	R1.25	2.40	4.5	25	50	3
TOBF 03025.3	R1.5	2.90	6.0	25	50	3
TOBF 00610.4	R0.3	0.56	2.5	10	50	4
TOBF 01018.4	R0.5	0.95	4.0	18	50	4
TOBF 02020.4	R1	1.92	4.5	20	50	4
TOBF 02522.4	R1.25	2.40	4.5	22	50	4
TOBF 00610.6	R0.3	0.56	2.5	10	50	6
TOBF 00812.6	R0.4	0.76	3.0	12	50	6
TOBF 01016.6	R0.5	0.95	4.0	16	50	6
TOBF 01018.6	R0.5	0.95	4.0	18	50	6
TOBF 01518.6	R0.75	1.45	4.0	18	50	6
TOBF 02020.6	R1	1.92	4.5	20	50	6
TOBF 02025.6	R1	1.92	4.5	25	50	6
TOBF 02522.6	R1.25	2.40	4.5	22	50	6
TOBF 02525.6	R1.25	2.40	4.5	25	50	6
TOBF 03025.6	R1.5	2.90	6.0	25	50	6

TOBF

148

www.hgt.com.tw

DEN.pro

TTBF

▶ Long Neck / Ball Nose / for CoCr . Titanium

unit: mm



Order No.	Radius R	Neck Dia D3	Flute Length L1	Effective Length L3	O.A.L. L2	Shank Dia D2
TTBF 00810.4	R0.4	0.76	3.5	10	50	4
TTBF 01012.4	R0.5	0.95	3.5	12	50	4
TTBF 01514.4	R0.75	1.45	4.0	14	50	4
TTBF 02016.4	R1	1.92	4.0	16	50	4
TTBF 02518.4	R1.25	2.40	4.5	18	50	4
TTBF 03022.4	R1.5	2.90	5.5	22	50	4
TTBF 00808.6	R0.4	0.76	3.5	8	50	6
TTBF 01008.6	R0.5	0.95	3.5	8	50	6
TTBF 01010.6	R0.5	0.95	3.5	10	50	6
TTBF 01012.6	R0.5	0.95	3.5	12	50	6
TTBF 01512.6	R0.75	1.45	4.0	12	50	6
TTBF 01516.6	R0.75	1.45	4.0	16	50	6
TTBF 02012.6	R1	1.92	4.0	12	50	6
TTBF 02016.6	R1	1.92	4.0	16	50	6
TTBF 02514.6	R1.25	2.40	4.5	14	50	6
TTBF 02518.6	R1.25	2.40	4.5	18	50	6
TTBF 03015.6	R1.5	2.90	5.5	15	50	6
TTBF 03017.6	R1.5	2.90	5.5	17	50	6
TTBF 03022.6	R1.5	2.90	5.5	22	50	6

TTBF

149

www.hgt.com.tw

DEN.pro

TTFA

▶ Long Neck / Square / for CoCr . Titanium

unit: mm

Order No.	Diameter D1	Neck Dia D3	Flute Length L1	Effective Length L3	O.A.L. L2	Shank Dia D2
TTFA 00505.4	0.5	0.46	1.0	5	50	4
TTFA 00808.4	0.8	0.76	1.2	8	50	4
TTFA 00910.4	0.9	0.85	1.2	10	50	4
TTFA 01015.4	1.0	0.95	1.5	15	50	4
TTFA 01215.4	1.2	1.15	1.5	15	50	4
TTFA 01516.4	1.5	1.45	2.0	16	50	4
TTFA 01616.4	1.6	1.54	2.5	16	50	4
TTFA 01816.4	1.8	1.92	2.5	16	50	4
TTFA 02016.4	2.0	1.92	3.0	16	50	4
TTFA 02518.4	2.5	2.40	3.0	18	50	4



TTFA

150

www.hgt.com.tw

DEN.pro

TTRA

▶ Long Neck / Corner Radius / for CoCr . Titanium

unit: mm

Order No.	Diameter D1	Corner R R	Neck Dia D3	Flute Length L1	Effective Length L3	O.A.L. L2	Shank Dia D2
TTRA 01015.4	1.0	0.1	0.95	1.5	15	50	4
TTRA 01215.4	1.2	0.1	1.15	1.5	15	50	4
TTRA 01516.4	1.5	0.2	1.45	2.0	16	50	4
TTRA 01816.4	1.8	0.2	1.73	2.5	16	50	4
TTRA 02016.4	2.0	0.2	1.92	3.0	16	50	4
TTRA 02518.4	2.5	0.2	2.40	3.0	18	50	4



DEN.pro

TTRB

▶ Long Neck / Corner Radius / for CoCr . Titanium

unit: mm

Order No.	Diameter D1	Corner R R	Neck Dia D3	Flute Length L1	Effective Length L3	O.A.L. L2	Shank Dia D2
TTRB 02012.6	2.0	0.2	1.92	4.0	12	50	6
TTRB 03014.6	3.0	0.3	2.90	5.0	14	50	6
TTRB 03018.6	3.0	0.3	2.90	5.0	18	50	6
TTRB 04016.6	4.0	0.4	3.88	6.0	16	50	6



www.hgt.com.tw

TTRA
TTRB

151

DEN.pro

TCBF

Long Neck / Ball Nose / for Composites

unit: mm

Order No.	Radius R	Neck Dia D3	Flute Length L1	Effective Length L3	O.A.L. L2	Shank Dia D2
TCBF 00812.6	R0.4	0.76	3.5	12	50	6
TCBF 01014.6	R0.5	0.95	3.5	14	50	6
TCBF 01516.6	R0.75	1.45	4.0	16	50	6
TCBF 02018.6	R1	1.92	4.0	18	50	6
TCBF 02520.6	R1.25	2.40	4.5	20	50	6
TCBF 03025.6	R1.5	2.90	5.5	25	50	6



TCBF

152

www.hgt.com.tw

DEN.pro

TWBF

Long Neck / Ball Nose / for PMMA. Wax

unit: mm

Order No.	Radius R	Neck Dia D3	Flute Length L1	Effective Length L3	O.A.L. L2	Shank Dia D2
TWBF 00812.4	R0.4	0.76	3.5	12	50	4
TWBF 01016.4	R0.5	0.95	3.5	16	50	4
TWBF 01518.4	R0.75	1.45	4.0	18	50	4
TWBF 02020.4	R1	1.92	4.0	20	50	4
TWBF 02525.4	R1.25	2.40	4.5	25	50	4
TWBF 03025.4	R1.5	2.90	5.5	25	50	4

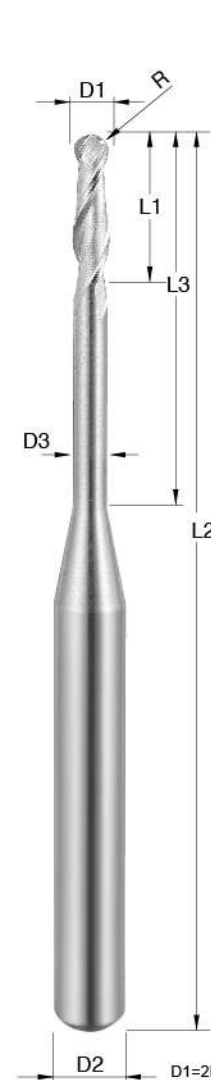

TWBF

153

www.hgt.com.tw

COM COM.pro

CFRP machining series

COM.pro

CFPA

► Square / for CFRP

unit: mm

Order No.	Diameter D1	Flute Length L1	O.A.L. L2	Shank Dia D2	Flutes
CFPA 0606	6.0	18	75	6	10
CFPA 0808	8.0	24	75	8	10
CFPA 1010	10.0	30	100	10	12
CFPA 1212	12.0	36	100	12	12

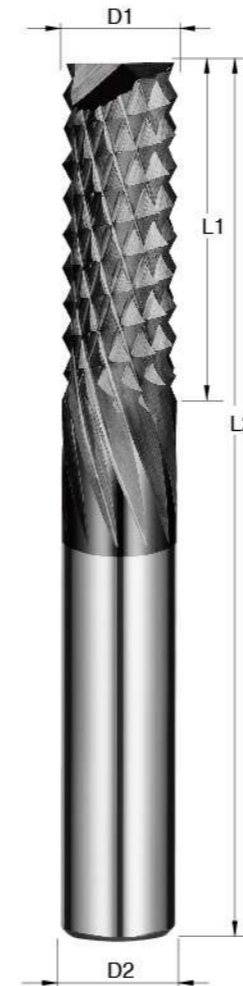

- G**
MG
- 10**
Flutes
- 12**
Flutes
- Diamond**
- Finishing
Semi-Finishing
- Side
- Slotting

COM.pro

CFRA

Corner Radius / for CFRP

unit: mm

Order No.	Diameter D1	Corner R R	Flute Length L1	O.A.L. L2	Shank Dia D2
CFRA 0602	6.0	0.2	18	75	6
CFRA 0802	8.0	0.2	24	75	8
CFRA 1002	10.0	0.2	30	100	10
CFRA 1202	12.0	0.2	36	100	12

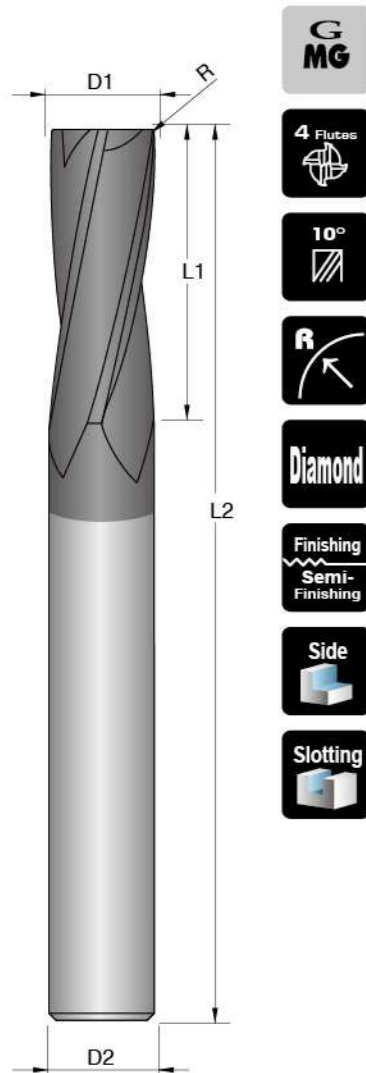

HGT

EX **MAGIC SHANK**

Magic shank series

MAGIC SHANK

EX2CS

► Carbide Shank

unit: mm

Order No.	Neck Dia D	Shank Dia D2	Neck Length L3	Thread M	O.A.L. L2
EX2CS 10100	9.7	10.0	40	M5	100
EX2CS 10150	9.7	10.0	90	M5	150
EX2CS 12100	11.7	12.0	40	M6	100
EX2CS 12150	11.7	12.0	90	M6	150
EX2CS 12200	11.7	12.0	110	M6	200
EX2CS 16100	15.5	16.0	40	M8	100
EX2CS 16150	15.5	16.0	90	M8	150
EX2CS 16200	15.5	16.0	110	M8	200
EX2CS 20100	19.5	20.0	40	M10	100
EX2CS 20150	19.5	20.0	90	M10	150
EX2CS 20200	19.5	20.0	110	M10	200
EX2CS 20250	19.5	20.0	150	M10	250

NEW

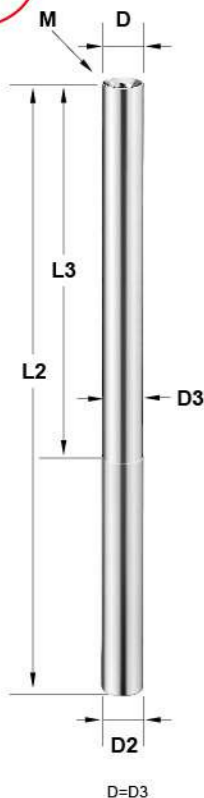

MAGIC SHANK

EX2SB

► Ex Ball Nose / for H P K

unit: mm

S MG
2 Flutes
30°
HRC 60
i8
Finishing Semi-Finishing
Profiling

Order No.	Radius R	Flute Length L1	Thread M	O.A.L. L2
EX2SB 1010	R5	10	M5	32
EX2SB 1212	R6	12	M6	40
EX2SB 1616	R8	16	M8	48
EX2SB 2020	R10	20	M10	55

NEW



MAGIC SHANK

EX2SRD

► Ex Corner Radius / for H P K

unit: mm

S MG
4 Flutes
45°
HRC 60
R
i8
Finishing Semi-Finishing
Profiling
Side

Order No.	Diameter D1	Corner R R	Flute Length L1	Thread M	O.A.L. L2
EX2SRD 1005	10.0	0.5	10	M5	32
EX2SRD 1010	10.0	1.0	10	M5	32
EX2SRD 1205	12.0	0.5	12	M6	40
EX2SRD 1210	12.0	1.0	12	M6	40
EX2SRD 1605	16.0	0.5	16	M8	48
EX2SRD 1610	16.0	1.0	16	M8	48
EX2SRD 2010	20.0	1.0	20	M10	55
EX2SRD 2020	20.0	2.0	20	M10	55

NEW



MAGIC SHANK

EX2SEB

► Ex Square / for H P K

unit: mm

S MG
4 Flutes
45°
HRC 60
i8
Finishing Semi-Finishing
Planing
Side

Order No.	Diameter D1	Flute Length L1	Thread M	O.A.L. L2
EX2SEB 1010	10.0	10	M5	32
EX2SEB 1212	12.0	12	M6	40
EX2SEB 1616	16.0	16	M8	48
EX2SEB 2020	20.0	20	M10	55

NEW



MAGIC SHANK

EX2DPW

EX Square / for **N**

unit: mm



Order No.	Diameter D1	Flute Length L1	Thread M	O.A.L. L2
EX2DPW 1010	10.0	10	M5	32
EX2DPW 1212	12.0	12	M6	40
EX2DPW 1616	16.0	16	M8	48
EX2DPW 2020	20.0	20	M10	55

NEW



Recommended cutting condition for EX2SB (HRC30~HRC60)

Item No.	R	O.A.L.	HRC30 - HRC60	
			SPEED min ⁻¹	FEED mm / min
EX2SB 1010	R5	150	6000	1200
EX2SB 1212	R6	150	5500	1500
EX2SB 1212	R6	200	4000	1000
EX2SB 1616	R8	150	5500	2000
EX2SB 1616	R8	200	3800	1000
EX2SB 2020	R10	150	4800	2000
EX2SB 2020	R10	200	4000	800
EX2SB 2020	R10	250	2600	500

Depth Of Cut: 0.15mm

Recommended cutting condition for EX2SRD (HRC30~HRC60)

Item No.	D x R	O.A.L.	HRC30 - HRC60	
			SPEED min ⁻¹	FEED mm / min
EX2SRD 1005	10.0 x 0.5	150	5800	1000
EX2SRD 1205	12.0 x 0.5	150	5500	1200
EX2SRD 1205	12.0 x 0.5	200	4000	350
EX2SRD 1605	16.0 x 0.5	150	5000	2000
EX2SRD 1605	16.0 x 0.5	200	3800	800
EX2SRD 2010	20.0 x 1.0	150	4500	2000
EX2SRD 2010	20.0 x 1.0	200	3800	800
EX2SRD 2010	20.0 x 1.0	250	2600	400

Depth Of Cut: 0.15mm

Recommended cutting condition for EX2SEB (HRC30~HRC60)

Item No.	D	O.A.L.	HRC30 - HRC60	
			SPEED min ⁻¹	FEED mm / min
EX2SEB 1010	10.0	150	5000	800
EX2SEB 1212	12.0	150	4800	1000
EX2SEB 1212	12.0	200	3800	400
EX2SEB 1616	16.0	150	4200	1000
EX2SEB 1616	16.0	200	3600	400
EX2SEB 2020	20.0	150	4200	1500
EX2SEB 2020	20.0	200	3200	600
EX2SEB 2020	20.0	250	2500	300

Depth Of Cut: 0.15mm

MAGIC SHANK

EX2SIW

EX Square / for **M S**

unit: mm



Order No.	Diameter D1	Flute Length L1	Thread M	O.A.L. L2
EX2SIW 1010	10.0	10	M5	32
EX2SIW 1212	12.0	12	M6	40
EX2SIW 1616	16.0	16	M8	48
EX2SIW 2020	20.0	20	M10	55

NEW



T T.pro

Thread milling series

T.pro

EMT

Internal Threading / for **H P K M S N** unit: mm

Order No.	Thread SIZE	Diameter D1	Flute Length L1	O.A.L. L2	Shank Dia D2	Flute
EMT 03P050	M3x0.5	2.2	5.3	50	6	3
EMT 04P070	M4x0.7	3.1	7.4	50	6	3
EMT 05P080	M5x0.8	3.6	9.2	50	6	3
EMT 06P100	M6x1.0	4.0	10.5	50	6	3
EMT 08P125	M8x1.25	5.0	14.4	50	6	3
EMT 10P150	M10x1.5	7.0	17.3	60	8	3
EMT 12P175	M12x1.75	8.0	20.1	60	8	3
EMT 16P200	M16x2.0	10.0	27.0	75	10	3
EMT 20P250	M20x2.5	14.0	33.8	100	14	4

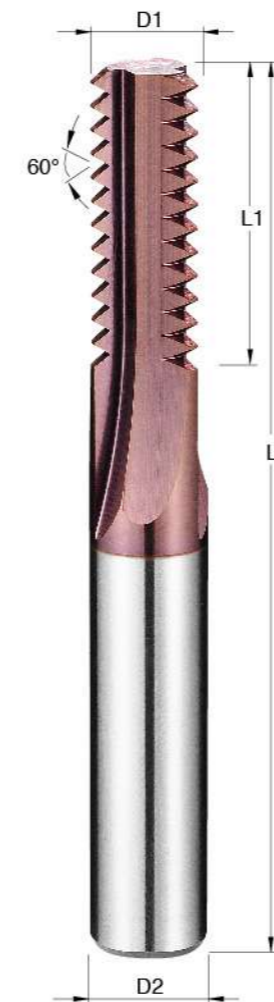

MG

HRC 55

G100

Finishing
Semi-Finishing

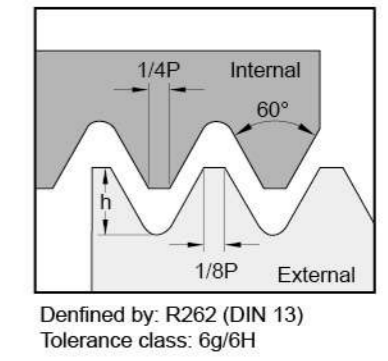
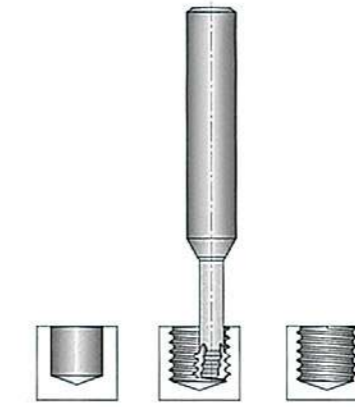

Recommended cutting condition for EMT

Work Hardness (HRC)	Vc (m/min)	Tool Dia (mm) / Feed f (mm/tooth)									
		2.2	3.1	3.6	4.0	5.0	7.0	8.0	10.0	14.0	
HRC45-55	50-60	0.015	0.02	0.025	0.03	0.035	0.05	0.055	0.07	0.1	
HRC55-60	40-50	0.012	0.015	0.02	0.025	0.03	0.035	0.04	0.05	0.08	

T.pro

EMTW

Internal Threading / Helical Flutes / for **H P K M S N** unit: mm

Order No.	Thread SIZE	Diameter D1	Flute Length L1	O.A.L. L2	Shank Dia D2	Flute
EMTW 03P050	M3x0.5	2.2	5.3	50	6	3
EMTW 04P070	M4x0.7	3.1	7.4	50	6	3
EMTW 05P080	M5x0.8	3.6	9.2	50	6	3
EMTW 06P100	M6x1.0	4.0	10.5	50	6	3
EMTW 08P125	M8x1.25	5.0	14.4	50	6	3
EMTW 10P150	M10x1.5	7.0	17.3	60	8	3
EMTW 12P175	M12x1.75	8.0	20.1	60	8	3
EMTW 16P200	M16x2.0	10.0	27.0	75	10	3
EMTW 20P250	M20x2.5	14.0	33.8	100	14	4

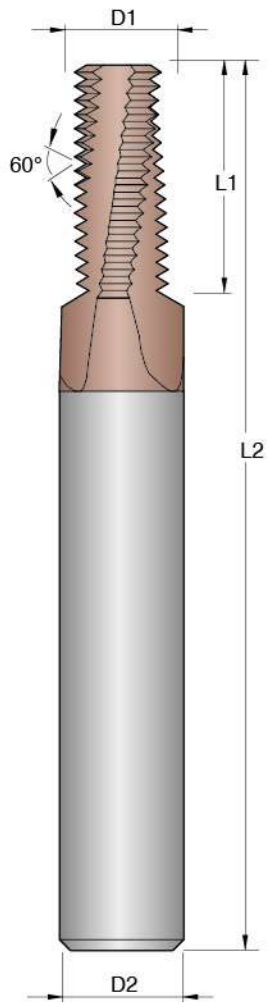
S
MGHRC
60

G100

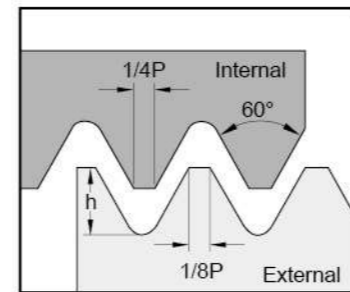
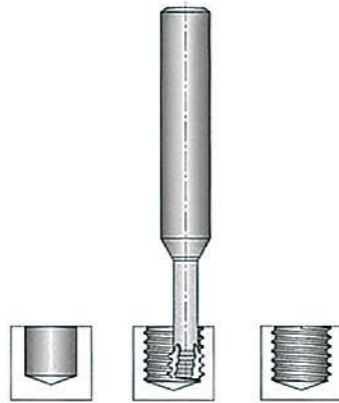
Finishing
Semi-FinishingDefined by: R262 (DIN 13)
Tolerance class: 6g/6H

T.pro

EMTH

Internal Threading / Helical Flutes / Hole Coolant / for **H P K M S N** unit: mm

Order No.	Thread SIZE	Diameter D1	Flute Length L1	O.A.L. L2	Shank Dia D2	Flute
EMTH 04P070	M4x0.7	3.1	7.4	50	6	3
EMTH 05P080	M5x0.8	3.8	9.2	50	6	3
EMTH 06P100	M6x1.0	4.6	10.5	50	6	3
EMTH 08P125	M8x1.25	6.0	14.4	50	6	3
EMTH 10P150	M10x1.5	7.8	17.3	60	8	3
EMTH 12P175	M12x1.75	9.0	20.1	75	10	3
EMTH 16P200	M16x2.0	11.8	27.0	75	12	3
EMTH 20P250	M20x2.5	15.0	33.8	100	16	4

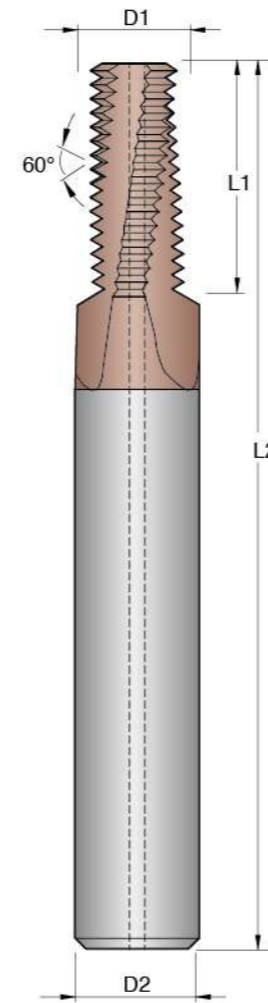
S
MGHRC
60

G100

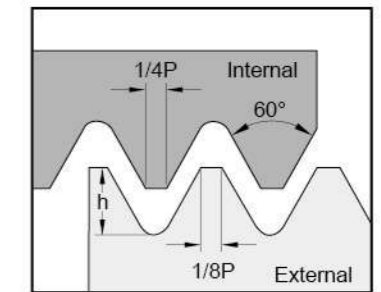
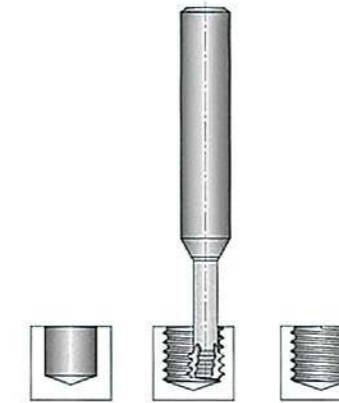
Finishing
Semi-FinishingDefined by: R262 (DIN 13)
Tolerance class: 6g/6H

T.pro

EMTS

Internal Threading / for **H P K M S N** unit: mm

Order No.	Thread SIZE	Diameter D1	Effective Length L3	O.A.L. L2	Shank Dia D2	Flute
EMTS 03P050	M3x0.5	2.35	10	50	6	3
EMTS 04P070	M4x0.7	3.10	13	50	6	3
EMTS 05P080	M5x0.8	3.80	16	50	6	3
EMTS 06P100	M6x1.0	4.65	20	75	6	3
EMTS 08P125	M8x1.25	5.95	24	75	6	3

Flute Length (L1) = Pitch x 3

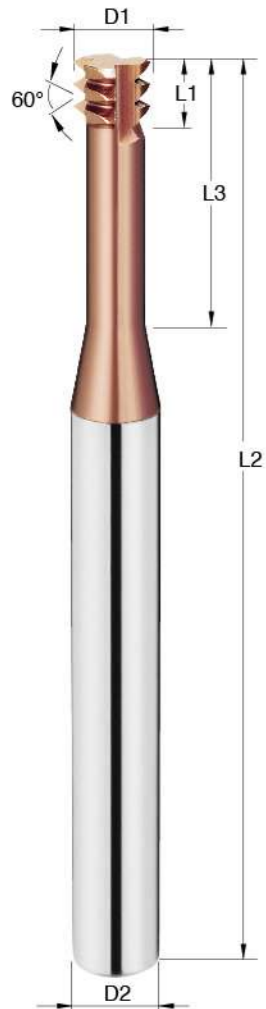
S
MGHRC
60

i8

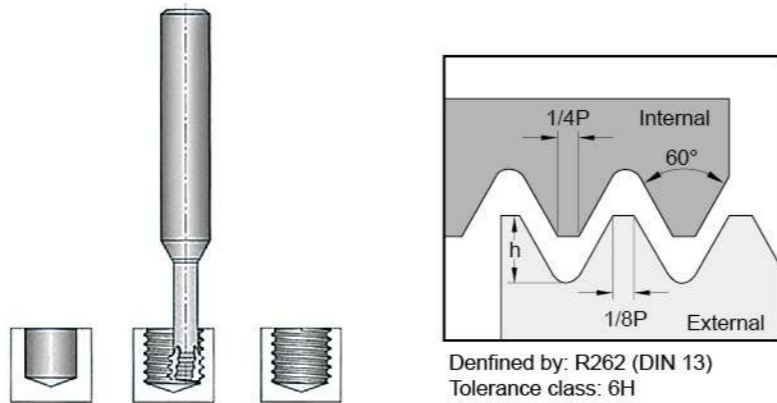
Finishing
Semi-Finishing

Recommended cutting condition for EMTS

Work Hardness (HRC)	Vc (m/min)	Tool Dia (mm) / Feed f (mm/tooth)				
		3.5	3.1	3.8	4.65	5.95
HRC45-55	50-60	0.015	0.02	0.025	0.03	0.035
HRC55-60	40-50	0.012	0.015	0.02	0.025	0.03

T.pro

EMTF

Internal Threading / for **H P K M S N** unit: mm

Order No.	Thread SIZE	Diameter D1	Effective Length L3	O.A.L. L2	Shank Dia D2	Flute
EMTF 03P050	M3x0.5	2.35	6	50	6	3
EMTF 04P070	M4x0.7	3.10	8	50	6	3
EMTF 05P080	M5x0.8	3.80	12	50	6	3
EMTF 06P100	M6x1.0	4.65	14	50	6	3
EMTF 08P125	M8x1.25	5.95	18	50	6	3
EMTF 10P150	M10x1.5	7.80	25	60	8	3
EMTF 12P175	M12x1.75	9.00	25	75	10	3

Flute Length (L1) = Pitch x 3



MG

HRC
55

G100

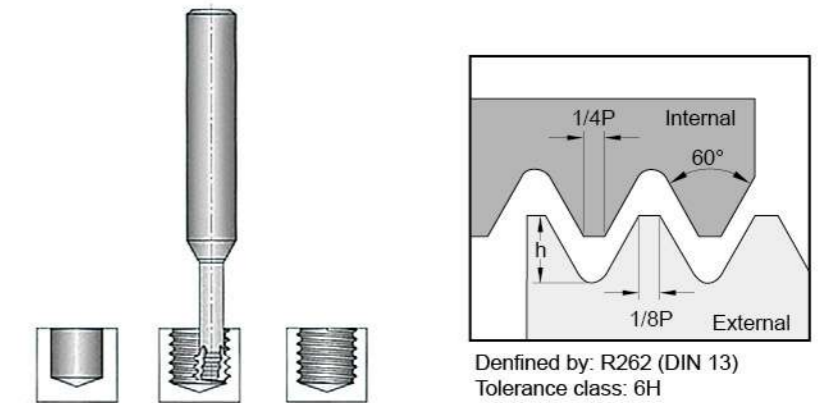
Finishing
Semi-Finishing

Recommended cutting condition for EMTF

Work Hardness (HRC)	Vc (m/min)	Tool Dia (mm) / Feed f (mm/tooth)						
		2.35	3.1	3.8	4.65	5.95	7.8	9.0
HRC45-55	50-60	0.015	0.02	0.025	0.03	0.035	0.05	0.055
HRC55-60	40-50	0.012	0.015	0.02	0.025	0.03	0.035	0.04

C C.pro

Chamfering series

C.pro

ECM

► Straight Chamfering / for **H** **P** **K** **M** **S** **N** unit: mm

Order No.	Tip Diameter D1	Flute Length L1	O.A.L. L2	Shank Dia D2
ECM 0104	1.0	1.5	50	4
ECM 0206	2.0	2.0	50	6
ECM 0208	2.0	3.0	60	8
ECM 0210	2.0	4.0	75	10
ECM 0212	2.0	5.0	75	12

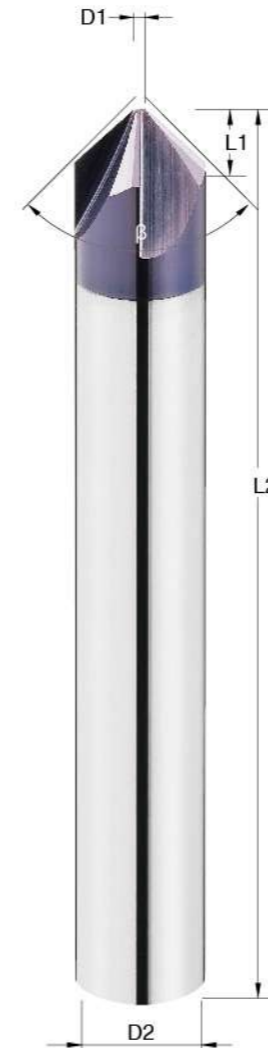

- MG**
- 4 Flutes
- 90° β
- HRC 55
- TiAlN
- Finishing
Semi-Finishing
- Side

C.pro

ECMP

► Straight Chamfering / for **H P K M S N** unit: mm

Order No.	Diameter D1	Tip Diameter D4	Flute Length L1	O.A.L. L2	Shank Dia D2
ECMP 0404	4.0	0.2	9	50	4
ECMP 0406	4.0	0.2	9	50	6
ECMP 0404B	4.0	0.2	9	100	4
ECMP 0606	6.0	0.2	12	50	6
ECMP 0606B	6.0	0.2	12	110	6
ECMP 0808	8.0	0.2	15	60	8
ECMP 0808B	8.0	0.2	15	110	8
ECMP 1010	10.0	0.2	16	75	10
ECMP 1010A	10.0	0.2	16	110	10
ECMP 1212	12.0	0.2	18	75	12

NEW

S
MG

4 Flutes

90°
βHRC
55

i8

Finishing
Semi-
Finishing

Side



▼ Recommended cutting condition for ECMP

Material	Carbon Steels/Cast Irons	Alloy Steels	Stainless Steels	Aluminum Alloys
	SS/S45C/FC	SCM/SKD	SUS304/SUS316L...	A2017/A5052/A7075
Cutting Speed (V)	50~80 m/min	35~60 m/min	20~40 m/min	100~150 m/min
Dia. (D1)	fz mm/min	fz mm/min	fz mm/min	fz mm/min
4	0.03~0.04	0.02~0.03	0.015~0.03	0.04~0.07
6	0.03~0.04	0.02~0.03	0.015~0.03	0.04~0.07
8	0.03~0.07	0.03~0.05	0.025~0.05	0.07~0.09
10	0.03~0.07	0.03~0.05	0.025~0.05	0.07~0.09
12	0.03~0.07	0.03~0.05	0.025~0.05	0.07~0.09

fz = Feed per Tooth

C.pro

ECMV

► Straight Chamfering / for **H P K M S N** unit: mm

Order No.	Diameter D1	Tip Diameter D4	Flute Length L1	O.A.L. L2	Shank Dia D2
ECMV 0404	4.0	0.2	1.5	50	4
ECMV 0406	4.0	0.2	1.5	50	6
ECMV 0606	6.0	0.2	2	50	6
ECMV 0808	8.0	0.2	3	60	8
ECMV 1010	10.0	0.2	4	75	10
ECMV 1212	12.0	0.2	5	75	12

NEW

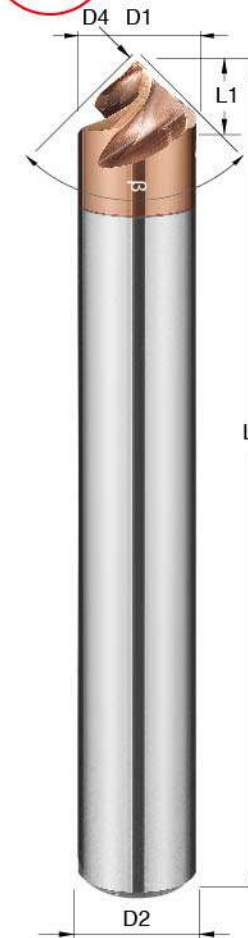
S
MG

3 Flutes

90°
βHRC
55

i8

Finishing
Semi-
Finishing

Side



▼ Recommended cutting condition for ECMV

Material	Carbon Steels/Cast Irons	Alloy Steels	Stainless Steels	Aluminum Alloys
	SS/S45C/FC	SCM/SKD	SUS304/SUS316L...	A2017/A5052/A7075
Cutting Speed (V)	50~80 m/min	35~60 m/min	20~40 m/min	100~150 m/min
Dia. (D1)	fz mm/min	fz mm/min	fz mm/min	fz mm/min
4	0.03~0.04	0.02~0.03	0.015~0.03	0.04~0.07
6	0.03~0.04	0.02~0.03	0.015~0.03	0.04~0.07
8	0.03~0.07	0.03~0.05	0.025~0.05	0.07~0.09
10	0.03~0.07	0.03~0.05	0.025~0.05	0.07~0.09
12	0.03~0.07	0.03~0.05	0.025~0.05	0.07~0.09

fz = Feed per Tooth

C.pro

ECR

► Corner Rounding / for H P K M S N unit: mm

Order No.	Radius R	Pilot Diameter D1	O.A.L. L2	Shank Dia D2
ECR 0104	R0.5	1.5	50	4
ECR 0154	R0.75	1.5	50	4
ECR 0204	R1.0	1.5	50	4
ECR 0256	R1.25	1.5	50	6
ECR 0306	R1.5	1.5	50	6
ECR 0356	R1.75	1.5	50	6
ECR 0406	R2.0	1.5	50	6
ECR 0508	R2.5	1.5	60	8
ECR 0608	R3.0	1.5	60	8
ECR 0812	R4.0	2.0	75	12
ECR 1016	R5.0	3.0	100	16
ECR 1216	R6.0	3.0	100	16

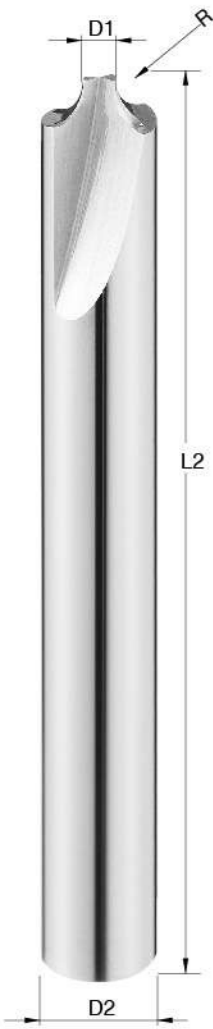

- MG**
- 2 Flutes
- HRC 55**
- Finishing
Semi-Finishing
- Side
- Side

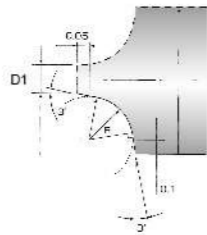

EMCR

► Micro Diameter Corner Rounding / for H P K M S N unit: mm

Order No.	Radius R	Pilot Diameter D1	O.A.L. L2	Shank Dia D2
EMCR 0054	R0.25	1.1	50	4
EMCR 0064	R0.3	1.2	50	4
EMCR 0074	R0.35	1.3	50	4
EMCR 0084	R0.4	1.4	50	4
EMCR 0094	R0.45	1.5	50	4

- MG**
- 2 Flutes
- HRC 55**
- Finishing
Semi-Finishing
- Side
- Side

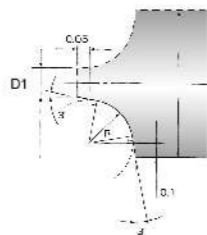

Carbide drills series

CD

ESD

ESD ▶ Spot Drills / for **H P K** unit: mm

Order No.	Diameter D1	Flute Length L1	O.A.L. L2	Shank Dia D2
ESD 0303	3.0	6	50	3
ESD 0404	4.0	8	50	4
ESD 0606	6.0	12	50	6
ESD 0808	8.0	16	60	8
ESD 1010	10.0	20	75	10
ESD 1212	12.0	24	75	12
ESD 1616	16.0	30	100	16
ESD 2020	20.0	30	100	20

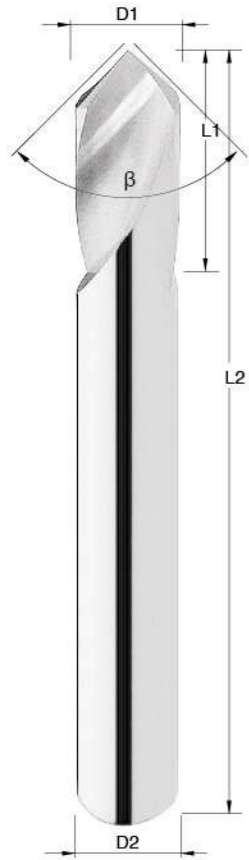

MG

90°
βHRC
40Finishing
Semi-Finishing

ESD2

ESD2 ▶ Spot Drills / for **H P K** unit: mm

Order No.	Diameter D1	Flute Length L1	O.A.L. L2	Shank Dia D2
ESD2 0303	3.0	6	50	3
ESD2 0404	4.0	8	50	4
ESD2 0606	6.0	12	50	6
ESD2 0808	8.0	16	60	8
ESD2 1010	10.0	20	75	10
ESD2 1212	12.0	24	75	12
ESD2 1616	16.0	30	100	16
ESD2 2020	20.0	30	100	20

MG

120°
βHRC
40Finishing
Semi-Finishing

CD

ESDC

ESDC ▶ Spot Drills / for **H P K** unit: mm

Order No.	Diameter D1	Flute Length L1	O.A.L. L2	Shank Dia D2
ESDC 0303	3.0	6	50	3
ESDC 0404	4.0	8	50	4
ESDC 0606	6.0	12	50	6
ESDC 0808	8.0	16	60	8
ESDC 1010	10.0	20	75	10
ESDC 1212	12.0	24	75	12
ESDC 1616	16.0	30	100	16
ESDC 2020	20.0	30	100	20

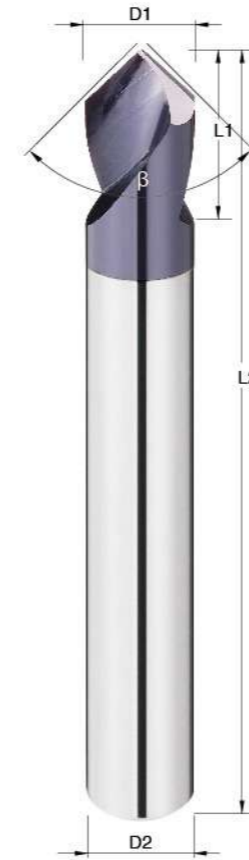

MG

90°
βHRC
40

TiAlN

Finishing
Semi-Finishing

ESDA

ESDA ▶ Spot Drills / for **H P K** unit: mm

Order No.	Diameter D1	Flute Length L1	O.A.L. L2	Shank Dia D2
ESDA 0303	3.0	6	50	3
ESDA 0404	4.0	8	50	4
ESDA 0606	6.0	12	50	6
ESDA 0808	8.0	16	60	8
ESDA 1010	10.0	20	75	10
ESDA 1212	12.0	24	75	12
ESDA 1616	16.0	30	100	16
ESDA 2020	20.0	30	100	20

MG

120°
βHRC
40

TiAlN

Finishing
Semi-Finishing

CD

ESDS

ESDS ▶ Long Shank Spot Drills / for **H P K** unit: mm

Order No.	Diameter D1	Flute Length L1	O.A.L. L2	Shank Dia D2
ESDS 0606	6.0	12	100	6
ESDS 0808	8.0	16	100	8
ESDS 1010	10.0	20	100	10
ESDS 1212	12.0	24	100	12
ESDS 1616	16.0	30	150	16
ESDS 2020	20.0	30	150	20

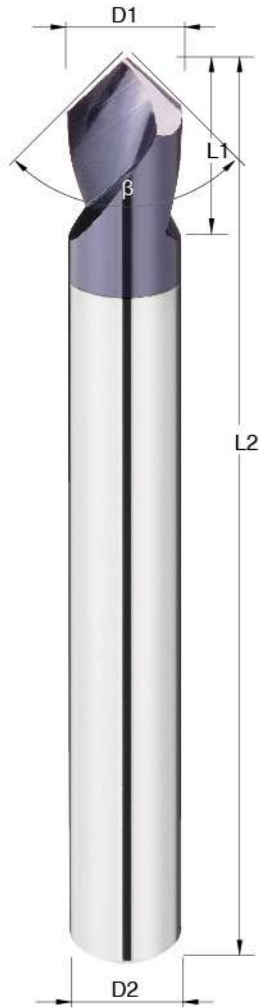

MG

90°
βHRC
40

TiAlN

Finishing
Semi-Finishing

ESDL

ESDL ▶ Long Shank Spot Drills / for **H P K** unit: mm

Order No.	Diameter D1	Flute Length L1	O.A.L. L2	Shank Dia D2
ESDL 0606	6.0	12	100	6
ESDL 0808	8.0	16	100	8
ESDL 1010	10.0	20	100	10
ESDL 1212	12.0	24	100	12
ESDL 1616	16.0	30	150	16
ESDL 2020	20.0	30	150	20

MG

120°
βHRC
40

TiAlN

Finishing
Semi-Finishing

CD

CCD

CCD ▶ Center Drills / for **H P K**

Order No.	Diameter D1	Flute Length L1	O.A.L. L2	Shank Dia D2
CCD 0050	0.50	0.8	38	3
CCD 0080	0.80	1.1	38	3
CCD 0100	1.00	1.3	38	3
CCD 0125	1.25	1.6	38	3
CCD 0160	1.60	2.0	38	4
CCD 0200	2.00	2.5	50	5
CCD 0250	2.50	3.1	50	6
CCD 0315	3.15	3.9	60	8
CCD 0400	4.00	5.0	75	10
CCD 0500	5.00	6.3	75	12

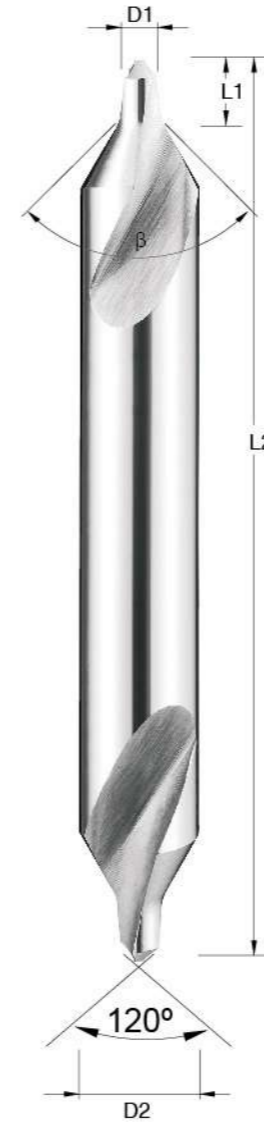

MG

60°
βHRC
55Finishing
Semi-Finishing

CCDA

CCDA ▶ Center Drills / for **H P K**

Order No.	Diameter D1	Flute Length L1	O.A.L. L2	Shank Dia D2
CCDA 0050	0.50	0.8	38	3
CCDA 0080	0.80	1.1	38	3
CCDA 0100	1.00	1.3	38	3
CCDA 0125	1.25	1.6	38	3
CCDA 0160	1.60	2.0	38	4
CCDA 0200	2.00	2.5	50	5
CCDA 0250	2.50	3.1	50	6
CCDA 0315	3.15	3.9	60	8
CCDA 0400	4.00	5.0	75	10
CCDA 0500	5.00	6.3	75	12

MG

90°
βHRC
55Finishing
Semi-Finishing

CD

CD

► Carbide Drills / for **H P K**

Order No.	Dia D1	Flute Length L1	O.A.L. L2	Order No.	Dia D1	Flute Length L1	O.A.L. L2
CD 020	2.0	12	38	CD 070	7.0	34	74
CD 021	2.1	12	38	CD 071	7.1	34	74
CD 022	2.2	13	40	CD 072	7.2	34	74
CD 023	2.3	13	40	CD 073	7.3	34	74
CD 024	2.4	14	43	CD 074	7.4	34	74
CD 025	2.5	14	43	CD 075	7.5	34	74
CD 026	2.6	14	43	CD 076	7.6	37	79
CD 027	2.7	16	46	CD 077	7.7	37	79
CD 028	2.8	16	46	CD 078	7.8	37	79
CD 029	2.9	16	46	CD 079	7.9	37	79
CD 030	3.0	16	46	CD 080	8.0	37	79
CD 031	3.1	18	49	CD 081	8.1	37	79
CD 032	3.2	18	49	CD 082	8.2	37	79
CD 033	3.3	18	49	CD 083	8.3	37	79
CD 034	3.4	20	52	CD 084	8.4	37	79
CD 035	3.5	20	52	CD 085	8.5	37	79
CD 036	3.6	20	52	CD 086	8.6	40	84
CD 037	3.7	20	52	CD 087	8.7	40	84
CD 038	3.8	22	55	CD 088	8.8	40	84
CD 039	3.9	22	55	CD 089	8.9	40	84
CD 040	4.0	22	55	CD 090	9.0	40	84
CD 041	4.1	22	55	CD 091	9.1	40	84
CD 042	4.2	22	55	CD 092	9.2	40	84
CD 043	4.3	24	58	CD 093	9.3	40	84
CD 044	4.4	24	58	CD 094	9.4	40	84
CD 045	4.5	24	58	CD 095	9.5	40	84
CD 046	4.6	24	58	CD 096	9.6	43	89
CD 047	4.7	24	58	CD 097	9.7	43	89
CD 048	4.8	26	62	CD 098	9.8	43	89
CD 049	4.9	26	62	CD 099	9.9	43	89
CD 050	5.0	26	62	CD 100	10.0	43	89
CD 051	5.1	26	62	CD 102	10.2	43	89
CD 052	5.2	26	62	CD 105	10.5	43	89
CD 053	5.3	26	62	CD 110	11.0	47	95
CD 054	5.4	28	66	CD 115	11.5	47	95
CD 055	5.5	28	66	CD 120	12.0	51	102
CD 056	5.6	28	66	CD 125	12.5	51	102
CD 057	5.7	28	66	CD 130	13.0	51	102
CD 058	5.8	28	66				
CD 059	5.9	28	66				
CD 060	6.0	28	66				
CD 061	6.1	31	70				
CD 062	6.2	31	70				
CD 063	6.3	31	70				
CD 064	6.4	31	70				
CD 065	6.5	31	70				
CD 066	6.6	31	70				
CD 067	6.7	31	70				
CD 068	6.8	34	74				
CD 069	6.9	34	74				



MG

DIN
6539

30°

h6

h7

120°
CD005-019140°
CD020-130

TiAlN

3xD

Finishing
Semi-Finishing

Cutting Data ► P.187

CD

CDA

► Carbide Drills / for **H P K**

Order No.	Dia D1	Flute Length L1	Overall Length L2	Shank Dia D2	Order No.	Dia D1	Flute Length L1	Overall Length L2	Shank Dia D2
CDA 030	3.0	20	62	6.0	CDA 085	8.5	47	89	10.0
CDA 031	3.1	20	62	6.0	CDA 086	8.6	47	89	10.0
CDA 032	3.2	20	62	6.0	CDA 087	8.7	47	89	10.0
CDA 033	3.3	20	62	6.0	CDA 088	8.8	47	89	10.0
CDA 034	3.4	20	62	6.0	CDA 089	8.9	47	89	10.0
CDA 035	3.5	20	62	6.0	CDA 090	9.0	47	89	10.0
CDA 036	3.6	20	62	6.0	CDA 091	9.1	47	89	10.0
CDA 037	3.7	20	62	6.0	CDA 092	9.2	47	89	10.0
CDA 038	3.8	24	66	6.0	CDA 093	9.3	47	89	10.0
CDA 039	3.9	24	66	6.0	CDA 094	9.4	47	89	10.0
CDA 040	4.0	24	66	6.0	CDA 095	9.5	47	89	10.0
CDA 041	4.1	24	66	6.0	CDA 096	9.6	47	89	10.0
CDA 042	4.2	24	66	6.0	CDA 097	9.7	47	89	10.0
CDA 043	4.3	24	66	6.0	CDA 098	9.8	47	89	10.0
CDA 044	4.4	24	66	6.0	CDA 099	9.9	47	89	10.0
CDA 045	4.5	24	66	6.0	CDA 100	10.0	47	89	10.0
CDA 046	4.6	24	66	6.0	CDA 101	10.1	55	102	12.0
CDA 047	4.7	24	66	6.0	CDA 102	10.2	55	102	12.0
CDA 048	4.8	28	66	6.0	CDA 103	10.3	55	102	12.0
CDA 049	4.9	28	66	6.0	CDA 104	10.4	55	102	12.0
CDA 050	5.0	28	66	6.0	CDA 105	10.5	55	102	12.0
CDA 051	5.1	28	66	6.0	CDA 106	10.6	55	102	12.0
CDA 052	5.2	28	66	6.0	CDA 107	10.7	55	102	12.0
CDA 053	5.3	28	66	6.0	CDA 108	10.8	55	102	12.0
CDA 054	5.4	28	66	6.0	CDA 109	10.9	55	102	12.0
CDA 055	5.5	28	66	6.0	CDA 110	11.0	55	102	12.0
CDA 056	5.6	28	66	6.0	CDA 111	11.1	55	102	12.0
CDA 057	5.7	28	66	6.0	CDA 112	11.2	55	102	12.0
CDA 058	5.8	28	66	6.0	CDA 113	11.3	55	102	12.0
CDA 059	5.9	28	66	6.0	CDA 114	11.4	55	102	12.0
CDA 060	6.0	28	66	6.0	CDA 115	11.5	55	102	12.0
CDA 061	6.1	34	79	8.0	CDA 116	11.6	55	102	12.0
CDA 062	6.2	34	79	8.0	CDA 117	11.7	55	102	12.0
CDA 063	6.3	34	79	8.0	CDA 118	11.8	55	102	12.0
CDA 064	6.4	34	79	8.0	CDA 119	11.9	55	102	12.0
CDA 065	6.5	34	79	8.0	CDA 120	12.0	55	102	12.0
CDA 066	6.6	34	79	8.0	CDA 125	12.5	60	107	14.0
CDA 067	6.7	34	79	8.0	CDA 130	13.0	60	107	14.0
CDA 068	6.8	34	79	8.0	CDA 135	13.5	60	107	14.0
CDA 069	6.9	34	79	8.0	CDA 140	14.0	60	107	14.0
CDA 070	7.0	34	79	8.0	CDA 145	14.5	65	115	16.0
CDA 071	7.1	41	79	8.0	CDA 150	15.0	65	115	16.0
CDA 072	7.2	41	79	8.0	CDA 155	15.5	65	115	16.0
CDA 073	7.3	41	79	8.0	CDA 160	16.0	65	115	16.0
CDA 074	7.4	41	79	8.0	CDA 165	16.5	73	123	18.0
CDA 075	7.5	41	79	8.0	CDA 170	17.0	73	123	18.0
CDA 076	7.6	41	79	8.0	CDA 175	17.5	73	123	18.0
CDA 077	7.7	41	79	8.0	CDA 180	18.0	73	123	18.0
CDA 078	7.8	41	79	8.0	CDA 185	18.5	79	131	20.0
CDA 079	7.9	41	79	8.0	CDA 190	19.0	79	131	20.0
CDA 080	8.0	41	79	8.0	CDA 195	19.5	79	131	20.0
CDA 081	8.1	47	89	10.0	CDA 200	20.0	79	131	20.0
CDA 082	8.2	47	89	10.0					
CDA 083	8.3	47	89	10.0					
CDA 084	8.4	47	89	10.0					



MG

DIN
6537

30°

h6

h7

140°

TiAlN

3xD

Finishing
Semi-Finishing

Cutting Data ► P.187

CD

CDB

Carbide Drills / for **H P K**

unit: mm



MG

DIN
6537

30°

h6

h7

140°

TiAlN

5xD

Finishing
Semi-Finishing

Order No.	Dia D1	Flute Length L1	Overall Length L2	Shank Dia D2
CDB 030	3.0	28	66	6.0
CDB 031	3.1	28	66	6.0
CDB 032	3.2	28	66	6.0
CDB 033	3.3	28	66	6.0
CDB 034	3.4	28	66	6.0
CDB 035	3.5	28	66	6.0
CDB 036	3.6	28	66	6.0
CDB 037	3.7	28	66	6.0
CDB 038	3.8	36	74	6.0
CDB 039	3.9	36	74	6.0
CDB 040	4.0	36	74	6.0
CDB 041	4.1	36	74	6.0
CDB 042	4.2	36	74	6.0
CDB 043	4.3	36	74	6.0
CDB 044	4.4	36	74	6.0
CDB 045	4.5	36	74	6.0
CDB 046	4.6	36	74	6.0
CDB 047	4.7	36	74	6.0
CDB 048	4.8	44	82	6.0
CDB 049	4.9	44	82	6.0
CDB 050	5.0	44	82	6.0
CDB 051	5.1	44	82	6.0
CDB 052	5.2	44	82	6.0
CDB 053	5.3	44	82	6.0
CDB 054	5.4	44	82	6.0
CDB 055	5.5	44	82	6.0
CDB 056	5.6	44	82	6.0
CDB 057	5.7	44	82	6.0
CDB 058	5.8	44	82	6.0
CDB 059	5.9	44	82	6.0
CDB 060	6.0	44	82	6.0
CDB 061	6.1	53	91	8.0
CDB 062	6.2	53	91	8.0
CDB 063	6.3	53	91	8.0
CDB 064	6.4	53	91	8.0
CDB 065	6.5	53	91	8.0
CDB 066	6.6	53	91	8.0
CDB 067	6.7	53	91	8.0
CDB 068	6.8	53	91	8.0
CDB 069	6.9	53	91	8.0
CDB 070	7.0	53	91	8.0
CDB 071	7.1	53	91	8.0
CDB 072	7.2	53	91	8.0
CDB 073	7.3	53	91	8.0
CDB 074	7.4	53	91	8.0
CDB 075	7.5	53	91	8.0
CDB 076	7.6	53	91	8.0
CDB 077	7.7	53	91	8.0
CDB 078	7.8	53	91	8.0
CDB 079	7.9	53	91	8.0
CDB 080	8.0	53	91	8.0
CDB 081	8.1	61	103	10.0
CDB 082	8.2	61	103	10.0
CDB 083	8.3	61	103	10.0
CDB 084	8.4	61	103	10.0

Cutting Data ▶ P.187

CD

CDC

Carbide Drills / for **H P K**

unit: mm



MG

DIN
6537

30°

h6

h7

140°

TiAlN

8xD

Finishing
Semi-Finishing

Order No.	Dia D1	Flute Length L1	Overall Length L2	Shank Dia D2
CDC 030	3.0	34	72	6.0
CDC 031	3.1	34	72	6.0
CDC 032	3.2	34	72	6.0
CDC 033	3.3	34	72	6.0
CDC 034	3.4	34	72	6.0
CDC 035	3.5	34	72	6.0
CDC 036	3.6	34	72	6.0
CDC 037	3.7	34	72	6.0
CDC 038	3.8	43	81	6.0
CDC 039	3.9	43	81	6.0
CDC 040	4.0	43	81	6.0
CDC 041	4.1	43	81	6.0
CDC 042	4.2	43	81	6.0
CDC 043	4.3	43	81	6.0
CDC 044	4.4	43	81	6.0
CDC 045	4.5	43	81	6.0
CDC 046	4.6	43	81	6.0
CDC 047	4.7	43	81	6.0
CDC 048	4.8	57	95	6.0
CDC 049	4.9	57	95	6.0
CDC 050	5.0	57	95	6.0
CDC 051	5.1	57	95	6.0
CDC 052	5.2	57	95	6.0
CDC 053	5.3	57	95	6.0
CDC 054	5.4	57	95	6.0
CDC 055	5.5	57	95	6.0
CDC 056	5.6	57	95	6.0
CDC 057	5.7	57	95	6.0
CDC 058	5.8	57	95	6.0
CDC 059	5.9	57	95	6.0
CDC 060	6.0	57	95	6.0
CDC 061	6.1	76	114	8.0
CDC 062	6.2	76	114	8.0
CDC 063	6.3	76	114	8.0
CDC 064	6.4	76	114	8.0
CDC 065	6.5	76	114	8.0
CDC 066	6.6	76	114	8.0
CDC 067	6.7	76	114	8.0
CDC 068	6.8	76	114	8.0
CDC 069	6.9	76	114	8.0
CDC 070	7.0	76	114	8.0
CDC 071	7.1	76	114	8.0
CDC 072	7.2	76	114	8.0
CDC 073	7.3	76	114	8.0
CDC 074	7.4	76	114	8.0
CDC 075	7.5	76	114	8.0
CDC 076	7.6	76	114	8.0
CDC 077	7.7	76	114	8.0
CDC 078	7.8	76	114	8.0
CDC 079	7.9	76	114	8.0
CDC080	8.0	76	114	8.0
CDC 081	8.1	95	142	10.0
CDC 082	8.2	95	142	10.0
CDC 083	8.3	95	142	10.0
CDC 084	8.4	95	142	10.0
CDC 085	8.5	95	142	10.0
CDC 086	8.6	95	142	10.0
CDC 087	8.7	95	142	10.0
CDC 088	8.8	95	142	10.0
CDC 089	8.9	95	142	10.0
CDC 090	9.0	95	142	10.0
CDC 091	9.1	95	142	10.0
CDC 092	9.2	95	142	10.0
CDC 093	9.3	95	142	10.0
CDC 094	9.4	95	142	10.0
CDC 095	9.5	95	142	10.0
CDC 096	9.6	95	142	10.0
CDC 097	9.7	95	142	10.0
CDC 098	9.8	95	142	10.0
CDC 099	9.9	95	142	10.0
CDC 100	10.0	95	142	10.0
CDC 101	10.1	114	162	12.0
CDC 102	10.2	114	162	12.0
CDC 103	10.3	114	162	12.0
CDC 104	10.4	114	162	12.0
CDC 105	10.5	114	162	12.0
CDC 106	10.6	114	162	12.0
CDC 107	10.7	114	162	12.0
CDC 108	10.8	114	162	12.0
CDC 109	10.9	114	162	12.0
CDC 110	11.0	114	162	12.0
CDC 111	11.1	114	162	12.0
CDC 112	11.2	114	162	12.0
CDC 113	11.3	114	162	12.0
CDC 114	11.4	114	162	12.0
CDC 115	11.5	114	162	12.0
CDC 116	11.6	114	162	12.0
CDC 117	11.7	114	162	12.0
CDC 118	11.8	114	162	12.0
CDC 119	11.9	114	162	12.0
CDC 120	12.0	114	162	12.0

Cutting Data ▶ P.187

CD

CDAC

Internal coolant / Carbide Drills / for **H** **P** **K**



MG

DIN
6537

30°

h6

h7

140°

i8

3xD

Finishing
Semi-Finishing

Order No.	Dia D1	Flute Length L1	Overall Length L2	Shank Dia D2
CDAC 030	3.0	20	62	6.0
CDAC 031	3.1	20	62	6.0
CDAC 032	3.2	20	62	6.0
CDAC 033	3.3	20	62	6.0
CDAC 034	3.4	20	62	6.0
CDAC 035	3.5	20	62	6.0
CDAC 036	3.6	20	62	6.0
CDAC 037	3.7	20	62	6.0
CDAC 038	3.8	24	66	6.0
CDAC 039	3.9	24	66	6.0
CDAC 040	4.0	24	66	6.0
CDAC 041	4.1	24	66	6.0
CDAC 042	4.2	24	66	6.0
CDAC 043	4.3	24	66	6.0
CDAC 044	4.4	24	66	6.0
CDAC 045	4.5	24	66	6.0
CDAC 046	4.6	24	66	6.0
CDAC 047	4.7	24	66	6.0
CDAC 048	4.8	28	66	6.0
CDAC 049	4.9	28	66	6.0
CDAC 050	5.0	28	66	6.0
CDAC 051	5.1	28	66	6.0
CDAC 052	5.2	28	66	6.0
CDAC 053	5.3	28	66	6.0
CDAC 054	5.4	28	66	6.0
CDAC 055	5.5	28	66	6.0
CDAC 056	5.6	28	66	6.0
CDAC 057	5.7	28	66	6.0
CDAC 058	5.8	28	66	6.0
CDAC 059	5.9	28	66	6.0
CDAC 060	6.0	28	66	6.0
CDAC 061	6.1	34	79	8.0
CDAC 062	6.2	34	79	8.0
CDAC 063	6.3	34	79	8.0
CDAC 064	6.4	34	79	8.0
CDAC 065	6.5	34	79	8.0
CDAC 066	6.6	34	79	8.0
CDAC 067	6.7	34	79	8.0
CDAC 068	6.8	34	79	8.0
CDAC 069	6.9	34	79	8.0
CDAC 070	7.0	34	79	8.0
CDAC 071	7.1	41	79	8.0
CDAC 072	7.2	41	79	8.0
CDAC 073	7.3	41	79	8.0
CDAC 074	7.4	41	79	8.0
CDAC 075	7.5	41	79	8.0
CDAC 076	7.6	41	79	8.0
CDAC 077	7.7	41	79	8.0
CDAC 078	7.8	41	79	8.0
CDAC 079	7.9	41	79	8.0
CDAC 080	8.0	41	79	8.0
CDAC 081	8.1	47	89	10.0
CDAC 082	8.2	47	89	10.0
CDAC 083	8.3	47	89	10.0
CDAC 084	8.4	47	89	10.0

Cutting Data ▶ P.187

CD

CDBC

Internal coolant / Carbide Drills / for **H** **P** **K**



MG

DIN
6537

30°

h6

h7

140°

i8

5xD

Finishing
Semi-Finishing

Order No.	Dia D1	Flute Length L1	Overall Length L2	Shank Dia D2
CDBC 030	3.0	28	66	6.0
CDBC 031	3.1	28	66	6.0
CDBC 032	3.2	28	66	6.0
CDBC 033	3.3	28	66	6.0
CDBC 034	3.4	28	66	6.0
CDBC 035	3.5	28	66	6.0
CDBC 036	3.6	28	66	6.0
CDBC 037	3.7	28	66	6.0
CDBC 038	3.8	36	74	6.0
CDBC 039	3.9	36	74	6.0
CDBC 040	4.0	36	74	6.0
CDBC 041	4.1	36	74	6.0
CDBC 042	4.2	36	74	6.0
CDBC 043	4.3	36	74	6.0
CDBC 044	4.4	36	74	6.0
CDBC 045	4.5	36	74	6.0
CDBC 046	4.6	36	74	6.0
CDBC 047	4.7	36	74	6.0
CDBC 048	4.8	44	82	6.0
CDBC 049	4.9	44	82	6.0
CDBC 050	5.0	44	82	6.0
CDBC 051	5.1	44	82	6.0
CDBC 052	5.2	44	82	6.0
CDBC 053	5.3	44	82	6.0
CDBC 054	5.4	44	82	6.0
CDBC 055	5.5	44	82	6.0
CDBC 056	5.6	44	82	6.0
CDBC 057	5.7	44	82	6.0
CDBC 058	5.8	44	82	6.0
CDBC 059	5.9	44	82	6.0
CDBC 060	6.0	44	82	6.0
CDBC 061	6.1	53	91	8.0
CDBC 062	6.2	53	91	8.0
CDBC 063	6.3	53	91	8.0
CDBC 064	6.4	53	91	8.0
CDBC 065	6.5	53	91	8.0
CDBC 066	6.6	53	91	8.0
CDBC 067	6.7	53	91	8.0
CDBC 068	6.8	53	91	8.0
CDBC 069	6.9	53	91	8.0
CDBC 070	7.0	53	91	8.0
CDBC 071	7.1	53	91	8.0
CDBC 072	7.2	53	91	8.0
CDBC 073	7.3	53	91	8.0
CDBC 074	7.4	53	91	8.0
CDBC 075	7.5	53	91	8.0
CDBC 076	7.6	53	91	8.0
CDBC 077	7.7	53	91	8.0
CDBC 078	7.8	53	91	8.0
CDBC 079	7.9	53	91	8.0
CDBC 080	8.0	53	91	8.0
CDBC 081	8.1	61	103	10.0
CDBC 082	8.2	61	103	10.0
CDBC 083	8.3	61	103	10.0
CDBC 084	8.4	61	103	10.0

Cutting Data ▶ P.187

CD

CDCC

Internal coolant / Carbide Drills / for **H** **P** **K**



MG

DIN
6537

30°

h6

h7

140°

i8

8xD

Finishing
Semi-
Finishing

Order No.	Dia D1	Flute Length L1	Overall Length L2	Shank Dia D2
CDCC 030	3.0	34	72	6.0
CDCC 031	3.1	34	72	6.0
CDCC 032	3.2	34	72	6.0
CDCC 033	3.3	34	72	6.0
CDCC 034	3.4	34	72	6.0
CDCC 035	3.5	34	72	6.0
CDCC 036	3.6	34	72	6.0
CDCC 037	3.7	34	72	6.0
CDCC 038	3.8	43	81	6.0
CDCC 039	3.9	43	81	6.0
CDCC 040	4.0	43	81	6.0
CDCC 041	4.1	43	81	6.0
CDCC 042	4.2	43	81	6.0
CDCC 043	4.3	43	81	6.0
CDCC 044	4.4	43	81	6.0
CDCC 045	4.5	43	81	6.0
CDCC 046	4.6	43	81	6.0
CDCC 047	4.7	43	81	6.0
CDCC 048	4.8	57	95	6.0
CDCC 049	4.9	57	95	6.0
CDCC 050	5.0	57	95	6.0
CDCC 051	5.1	57	95	6.0
CDCC 052	5.2	57	95	6.0
CDCC 053	5.3	57	95	6.0
CDCC 054	5.4	57	95	6.0
CDCC 055	5.5	57	95	6.0
CDCC 056	5.6	57	95	6.0
CDCC 057	5.7	57	95	6.0
CDCC 058	5.8	57	95	6.0
CDCC 059	5.9	57	95	6.0
CDCC 060	6.0	57	95	6.0
CDCC 061	6.1	76	114	8.0
CDCC 062	6.2	76	114	8.0
CDCC 063	6.3	76	114	8.0
CDCC 064	6.4	76	114	8.0
CDCC 065	6.5	76	114	8.0
CDCC 066	6.6	76	114	8.0
CDCC 067	6.7	76	114	8.0
CDCC 068	6.8	76	114	8.0
CDCC 069	6.9	76	114	8.0
CDCC 070	7.0	76	114	8.0
CDCC 071	7.1	76	114	8.0
CDCC 072	7.2	76	114	8.0
CDCC 073	7.3	76	114	8.0
CDCC 074	7.4	76	114	8.0
CDCC 075	7.5	76	114	8.0

Order No.	Dia D1	Flute Length L1	Overall Length L2	Shank Dia D2
CDCC 076	7.6	76	114	8.0
CDCC 077	7.7	76	114	8.0
CDCC 078	7.8	76	114	8.0
CDCC 079	7.9	76	114	8.0
CDCC 080	8.0	76	114	8.0
CDCC 081	8.1	95	142	10.0
CDCC 082	8.2	95	142	10.0
CDCC 083	8.3	95	142	10.0
CDCC 084	8.4	95	142	10.0
CDCC 085	8.5	95	142	10.0
CDCC 086	8.6	95	142	10.0
CDCC 087	8.7	95	142	10.0
CDCC 088	8.8	95	142	10.0
CDCC 089	8.9	95	142	10.0
CDCC 090	9.0	95	142	10.0
CDCC 091	9.1	95	142	10.0
CDCC 092	9.2	95	142	10.0
CDCC 093	9.3	95	142	10.0
CDCC 094	9.4	95	142	10.0
CDCC 095	9.5	95	142	10.0
CDCC 096	9.6	95	142	10.0
CDCC 097	9.7	95	142	10.0
CDCC 098	9.8	95	142	10.0
CDCC 099	9.9	95	142	10.0
CDCC 100	10.0	95	142	10.0

Cutting Data ▶ P.187

HGT

CR **CR**

Carbide reamers series

CR

CRA

► Carbide Reamers / for **H** **P** **K**

unit: mm

**MG**

7°

HRC 45

Finishing

Order No.	Dia D1	Flute Length L1	Overall Length L2	Flutes
CRA020	2.0	11	49	4
CRA021	2.1	11	49	4
CRA022	2.2	12	53	4
CRA023	2.3	12	53	4
CRA024	2.4	14	57	4
CRA025	2.5	14	57	4
CRA026	2.6	14	57	4
CRA027	2.7	15	61	4
CRA028	2.8	15	61	4
CRA029	2.9	15	61	4
CRA030	3.0	15	61	4
CRA031	3.1	16	65	4
CRA032	3.2	16	65	4
CRA033	3.3	16	65	4
CRA034	3.4	18	70	4
CRA035	3.5	18	70	4
CRA036	3.6	18	70	4
CRA037	3.7	18	70	4
CRA038	3.8	19	75	4
CRA039	3.9	19	75	4
CRA040	4.0	19	75	4
CRA041	4.1	19	75	4
CRA042	4.2	19	75	4
CRA043	4.3	21	80	4
CRA044	4.4	21	80	4
CRA045	4.5	21	80	4
CRA046	4.6	21	80	6
CRA047	4.7	21	80	6
CRA048	4.8	23	86	6
CRA049	4.9	23	86	6
CRA050	5.0	23	86	6
CRA051	5.1	23	86	6
CRA052	5.2	23	86	6
CRA053	5.3	23	86	6
CRA054	5.4	26	93	6
CRA055	5.5	26	93	6
CRA056	5.6	26	93	6
CRA057	5.7	26	93	6
CRA058	5.8	26	93	6
CRA059	5.9	26	93	6
CRA060	6.0	26	93	6
CRA061	6.1	28	101	6
CRA062	6.2	28	101	6
CRA063	6.3	28	101	6
CRA064	6.4	28	101	6
CRA065	6.5	28	101	6
CRA066	6.6	28	101	6
CRA067	6.7	31	101	6
CRA068	6.8	31	109	6
CRA069	6.9	31	109	6

Order No.	Dia D1	Flute Length L1	Overall Length L2	Flutes
CRA070	7.0	31	109	6
CRA071	7.1	31	109	6
CRA072	7.2	31	109	6
CRA073	7.3	31	109	6
CRA074	7.4	31	109	6
CRA075	7.5	31	109	6
CRA076	7.6	33	117	6
CRA077	7.7	33	117	6
CRA078	7.8	33	117	6
CRA079	7.9	33	117	6
CRA080	8.0	33	117	6
CRA081	8.1	33	117	6
CRA082	8.2	33	117	6
CRA083	8.3	33	117	6
CRA084	8.4	33	117	6
CRA085	8.5	33	117	6
CRA086	8.6	36	125	6
CRA087	8.7	36	125	6
CRA088	8.8	36	125	6
CRA089	8.9	36	125	6
CRA090	9.0	36	125	6
CRA091	9.1	36	125	6
CRA092	9.2	36	125	6
CRA093	9.3	36	125	6
CRA094	9.4	36	125	6
CRA095	9.5	36	125	6
CRA096	9.6	38	133	6
CRA097	9.7	38	133	6
CRA098	9.8	38	133	6
CRA099	9.9	38	133	6
CRA100	10.0	38	133	6
CRA101	10.1	38	133	6
CRA102	10.2	38	133	6
CRA103	10.3	38	133	6
CRA104	10.4	38	133	6
CRA105	10.5	38	133	6
CRA106	10.6	38	133	6
CRA107	10.7	41	142	6
CRA108	10.8	41	142	6
CRA109	10.9	41	142	6
CRA110	11.0	41	142	6
CRA111	11.1	41	142	6
CRA112	11.2	41	142	6
CRA113	11.3	41	142	6
CRA114	11.4	41	142	6
CRA115	11.5	41	142	6
CRA116	11.6	41	142	6
CRA117	11.7	41	142	6
CRA118	11.8	41	142	6
CRA119	11.9	44	151	6
CRA120	12.0	44	151	6

Cutting Data ► P.187

Recommended cutting condition

Recommended cutting condition for CD CDA CDB CDAC CDBC

MATERIAL	Carbon Steels . Alloy Steels S45C, FC, FCD, SCM, S50C, SKS...		Alloy Steels . Tool Steels SCr, SNCM, SKD11, SKD61, NAK80...		Hardened Steels SKD11	
	HRC35		HRC45		HRC55	
DIAMETER	Vc (m / min)	FEED (mm / rev.)	Vc (m / min)	FEED (mm / rev.)	Vc (m / min)	FEED (mm / rev.)
2	110-140	0.05-0.08	85-115	0.05-0.07	25-50	0.02-0.03
3	110-140	0.12-0.15	85-115	0.08-0.11	25-50	0.04-0.48
4	110-140	0.16-0.20	85-115	0.10-0.15	25-50	0.05-0.06
5	110-140	0.16-0.20	85-115	0.10-0.15	25-50	0.05-0.06
6	110-140	0.20-0.24	85-115	0.12-0.18	25-50	0.06-0.08
8	110-140	0.25-0.30	85-115	0.16-0.23	25-50	0.08-0.11
10	110-140	0.31-0.32	85-115	0.20-0.30	25-50	0.10-0.12
12	110-140	0.31-0.38	85-115	0.20-0.30	25-50	0.10-0.12
16	110-140	0.40-0.48	85-115	0.25-0.38	25-50	0.12-0.15
20	110-140	0.50-0.65	85-115	0.30-0.48	25-50	0.16-0.20

Recommended cutting condition for CDC CDCC

MATERIAL	Carbon Steels . Alloy Steels S45C, FC, FCD, SCM, S50C, SKS...		Alloy Steels . Tool Steels SCr, SNCM, SKD11, SKD61, NAK80...		Hardened Steels SKD11	
	HRC35		HRC45		HRC55	
DIAMETER	Vc (m / min)	FEED (mm / rev.)	Vc (m / min)	FEED (mm / rev.)	Vc (m / min)	FEED (mm / rev.)
3	110-140	0.08-0.11	85-115	0.05-0.08	25-50	0.02-0.03
4	110-140	0.10-0.15	85-115	0.06-0.11	25-50	0.03-0.04
5	110-140	0.10-0.15	85-115	0.06-0.11	25-50	0.03-0.04
6	110-140	0.12-0.18	85-115	0.08-0.15	25-50	0.05-0.06
8	110-140	0.16-0.23	85-115	0.11-0.18	25-50	0.06-0.07
10	110-140	0.20-0.30	85-115	0.14-0.24	25-50	0.07-0.09
12	110-140	0.20-0.30	85-115	0.14-0.24	25-50	0.08-0.10

Recommended cutting condition for CRA

Dia. (mm)	Vc (m/min)		Dia. (mm)	Feed (mm/rev)	
	Carbon Steels, Alloy Steels ~HRC40	Alloy Steels, Tool Steels HRC45~		Carbon Steels, Alloy Steels ~HRC40	Alloy Steels, Tool Steels HRC45~
2.0	14	8	2.0	0.05	0.04
3.0	14	8	3.0	0.08	0.06
4.0	14	8	4.0	0.1	0.08
5.0	14	8	5.0	0.1	0.08
6.0	14	8	6.0	0.12	0.1
8.0	14	8	8.0	0.16	0.12
10.0	14	8	10.0	0.2	0.16
12.0	14	8	12.0	0.2	0.16

Ball Nose End Milling Real Diameter

		(Ad) Depth of Cut (mm)														
Ball : R	Dia.	0.01	0.02	0.03	0.04	0.05	0.08	0.1	0.15	0.2	0.3	0.5	0.8	1.0	2.0	3.0
0.1	0.2	0.087	0.12	0.143	0.16	0.173	0.196	0.2	-----	-----	-----	-----	-----	-----	-----	-----
0.2	0.4	0.125	0.174	0.211	0.24	0.265	0.32	0.35	0.39	0.4	-----	-----	-----	-----	-----	-----
0.3	0.6	0.154	0.215	0.262	0.299	0.332	0.41	0.45	0.52	0.57	0.6	-----	-----	-----	-----	-----
0.4	0.8	0.178	0.25	0.304	0.349	0.387	0.48	0.53	0.62	0.69	0.77	0.77	-----	-----	-----	-----
0.5	1	0.199	0.28	0.341	0.392	0.436	0.54	0.6	0.71	0.8	0.92	1	-----	-----	-----	-----
1	2	0.282	0.398	0.486	0.56	0.624	0.78	0.87	1.05	1.2	1.43	1.73	1.96	2	-----	-----
1.5	3	0.346	0.488	0.597	0.688	0.768	0.97	1.08	1.31	1.5	1.8	2.24	2.65	2.83	2.83	-----
2	4	0.399	0.564	0.69	0.796	0.889	1.12	1.25	1.52	1.74	2.11	2.65	3.2	3.46	4	-----
2.5	5	0.447	0.631	0.772	0.891	0.995	1.25	1.4	1.71	1.96	2.37	3	3.67	4	4.9	4.9
3	6	0.489	0.692	0.846	0.977	1.091	1.38	1.54	1.87	2.15	2.62	3.32	4.08	4.47	5.66	6
4	8	0.565	0.799	0.978	1.129	1.261	1.59	1.78	2.17	2.5	3.04	3.87	4.8	5.29	6.93	7.75
5	10	0.632	0.894	1.094	1.262	1.411	1.78	1.99	2.43	2.8	3.41	4.36	5.43	6	8	9.17
6	12	0.693	0.979	1.198	1.383	1.546	1.95	2.18	2.67	3.07	3.75	4.8	5.99	6.63	8.94	10.39
7	14	0.748	1.058	1.295	1.495	1.67	2.11	2.36	2.88	3.32	4.05	5.2	6.5	7.21	9.8	11.49
8	16	0.8	1.131	1.384	1.598	1.786	2.26	2.52	3.08	3.56	4.34	5.57	6.97	7.75	10.58	12.49
9	18	0.848	1.199	1.468	1.695	1.895	2.39	2.68	3.27	3.77	4.61	5.92	7.42	8.25	11.31	13.42
10	20	0.894	1.264	1.548	1.787	1.997	2.52	2.82	3.45	3.98	4.86	6.24	7.84	8.72	12	14.28

Calculation of Real Dia.

$$d = 2 \sqrt{Ad(D-Ad)}$$

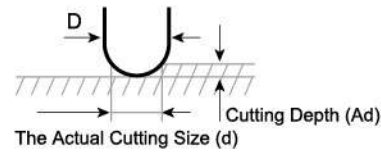

Spindle Speed Table

Dia	V (m/min)														
	20	30	40	50	60	70	80	90	100	120	150	180	200	250	300
0.5	12740	19110	25480	31850	38220	44590	50960	57320	63690	76430	95540	114650	127390	159240	191080
0.6	10620	15920	21230	26540	31850	37150	42460	47770	53080	63690	79620	95540	106160	132700	159240
0.7	9100	13650	18200	22750	27300	31850	36400	40950	45500	54590	68240	81890	90990	113740	136490
0.8	7960	11940	15920	19900	23890	27870	31850	35830	39810	47770	59710	71660	79620	99520	119430
0.9	7080	10620	14150	17690	21230	24770	28310	31850	35390	42640	53080	63690	70770	88460	106160
1	6370	9550	12740	15920	19110	22290	25480	28660	31850	38220	47770	57320	63390	79620	95540
2	3180	4780	6370	7960	9550	11150	12740	14330	15920	19110	23890	28660	31850	39810	47770
3	2120	3180	4250	5310	6370	7430	8490	9550	10620	12740	15920	19110	21230	26540	31850
4	1590	2390	3180	3980	4780	5570	6370	7170	7960	9550	11940	14330	15920	19900	23890
5	1270	1910	2550	3180	3820	4460	5100	5730	6370	7640	9550	11460	12740	15920	19110
6	1060	1590	2120	2650	3180	3720	4250	4780	5310	6370	7960	9550	10620	13270	15920
8	800	1190	1590	1990	2390	2790	3180	3580	3980	4780	5970	7170	7960	9950	11940
10	640	960	1270	1590	1910	2230	2550	2870	3180	3820	4780	5730	6370	7960	9550
12	530	800	1060	1330	1590	1860	2120	2390	2650	3180	3980	4780	5310	6630	7960
14	450	680	910	1140	1360	1590	1820	2050	2270	2730	3410	4090	4550	5690	6820
15	420	640	850	1060	1270	1490	1700	1910	2120	2550	3180	3820	4250	5310	6370
16	400	600	800	1000	1190	1390	1590	1790	1990	2390	2990	3580	3980	4980	5970
20	320	480	640	800	960	1110	1270	1430	1590	1910	2390	2870	3180	3980	4780
25	250	380	510	640	760	890	1020	1150	1270	1530	1910	2290	2550	3180	3820

$$V = \frac{\pi D N}{1000}$$

$$F = N \times Z \times f$$

V Cutting Speed (m/min)
 π Circular constant (3.14)
 D Diameter (mm)
 N RPM (min⁻¹)

Z Number of Flutes
 f Feed per Tooth (mm/Tooth)
 F Feed (mm/min)

Calculation for Cutting Speed, Spindle Speed and Feed

$$\text{Cutting Speed (V)} = \frac{\pi \times D \times N}{1,000}$$

$$\text{Spindle Speed (N)} = \frac{V \times 1,000}{\pi \times D}$$

$$\text{Feed (F)} = N \times f \times Z$$

$$\text{Feed per Tooth (fz)} = \frac{F}{N \times Z}$$

V = Cutting Speed (m/min)
 π = 3.14 The circular Constant
 D = Diameter (mm)
 N = RPM (min⁻¹)
 F = Feed (mm/min)
 fz = Feed per Tooh (mm/tooth)
 Z = Number of Flutes

Selection of Number of Flute

	2-Flutes	3-Flutes	4-Flutes	6-Flutes
Slotting				
Side Milling				

Generally 2-flutes and 3-flutes are selected for slotting because of the larger chip pocket. 4-flutes and 6-flutes are recommended for side milling as no promble of chip disposal.

Cutting Speed (V)

Appropriate Cutting Speed should be decided by parameters such as tool material, diameter, length of cut, work material, cutting machine, rigidity of tool holder, machining configuration, accuracy, cutting fluid, and etc. Generally tool material and work material are main factors to determine the Cutting Speed.

Work Materials	Cutting Speed (m/min)	
	Carbide	Coated Carbide
Carbon Steels (S50C)	20 ~ 40	40 ~ 80
Alloy Steels (SCM.SKD)	20 ~ 35	35 ~ 60
Prehardened Steels (NAK.HPM)	15 ~ 30	30 ~ 50
Stainless Steels (SUS304)	5 ~ 20	10 ~ 30
Hardened Steels (SKD61.HRC60)	-	20 ~ 40

Feed per Tooth (fz)

Feed per Tooth is an important element for efficient machining which should be determined by parameters such as tool diameter, type, work material, cutting machine, rigidity of tool holder, machining configuration, accuracy and cutting depth.

Diameter(mm)	Feed per tooth (mm/tooth)	
	2-Flutes	4-Flutes
1	0.001 ~ 0.005	
6	0.02 ~ 0.04	0.01 ~ 0.03
10	0.04 ~ 0.08	0.03 ~ 0.06
20	0.08 ~ 0.12	0.06 ~ 0.1

■ Comparison Table of Hardness

Rockwell Hardness C Scale 150kg Brale (HRC)	Diamond Pyramid Hardness Number, Vickers (HV)	Brinell Hardness Standard 10mm Ball 29.42kN (HB)	Rockwell Hardness A Scale 60kg Brale (HRA)	Shore Scleroscope Hardness Number (HS)	Approx Tensile Strength N/mm ²
68	940	-	85.6	97	-
67	900	-	85.5	95	-
66	865	-	84.5	92	-
65	832	-	83.9	91	-
64	800	-	83.4	88	-
63	772	-	82.8	87	-
62	746	-	82.3	85	-
61	720	-	81.8	83	-
60	697	-	81.2	81	-
59	674	-	80.7	80	-
58	653	-	80.1	78	-
57	633	-	79.6	76	-
56	613	-	79.0	75	-
55	595	-	78.5	74	2079
54	577	-	78.0	72	2010
53	560	-	77.4	71	1952
52	544	500	76.8	69	1883
51	528	487	76.3	68	1824
50	513	475	75.9	67	1755
49	498	464	75.2	66	1687
48	484	451	74.7	64	1639
47	471	442	74.1	63	1578
46	458	432	73.6	62	1530
45	446	421	73.1	60	1481
44	434	409	72.5	58	1432
43	423	400	72.0	57	1383
42	412	390	71.5	56	1334
41	402	381	70.9	55	1294
40	392	371	70.4	54	1245
39	382	362	69.9	52	1216
38	372	353	69.4	51	1177
37	363	344	68.9	50	1157
36	354	336	68.4	49	1118
35	345	327	67.9	48	1079
34	336	319	67.4	47	1059
33	327	311	66.8	46	1030
32	318	301	66.3	44	1000
31	310	294	65.8	43	981
30	302	286	65.3	42	952
29	294	279	64.7	41	932
28	285	271	64.3	41	912
27	279	264	63.8	40	883
26	272	258	63.3	38	863
25	266	253	62.8	38	843
24	260	247	62.4	37	824
23	254	243	62.0	36	804
22	248	237	61.5	35	785
21	243	231	61.0	35	775
20	238	226	60.5	34	755
(18)	230	219	-	33	736
(16)	222	212	-	32	706
(14)	213	203	-	31	677
(12)	204	194	-	29	647
(10)	196	187	-	28	618
(8)	188	179	-	27	598
(6)	180	171	-	26	579
(4)	173	165	-	25	549
(2)	166	158	-	24	530
(0)	160	152	-	24	520

■ Factors for End Mill Operation

Factor	Instruction and Advice
Rigidity of Machine	<ol style="list-style-type: none"> 1. Use a right machine. 2. Adjust cutting conditions according to the rigidity of machine.
Collet Chuck and Run out of End Mill	<ol style="list-style-type: none"> 1. Use a right and precise collet chuck. 2. Minimize the run out of end mill.
Work Clamp	<ol style="list-style-type: none"> 1. Work piece must be firmly clamped. 2. In case work piece cannot be firmly clamped, relieve cutting condition.
Cutting Fluid and Chips	<ol style="list-style-type: none"> 1. Give a sufficient cutting fluid. 2. Recommend water-base cutting fluid for heavy cutting. 3. Some end mills apply dry cutting only. 4. Use air blow for dry cutting. 5. Remove chips from working area.
Selection of End Mill	<ol style="list-style-type: none"> 1. Select most suitable end mills according to work material and dimension. 2. Refer to the index table on front page.
Cutting Conditions	<ol style="list-style-type: none"> 1. Refer to recommended milling condition table. 2. It is necessary to adjust conditions according to the machine rigidity and clamping condition of work piece.
Overhang of End Mill from tool holder	<ol style="list-style-type: none"> 1. Overhang of end mill must be as short as possible from tool holder. 2. In case overhang cannot be shorten, relieve cutting condition.

■ Troubleshooting for End Mill Operation

Symptoms of troubles	Cause	Solution
Chattering	<ul style="list-style-type: none"> · Excessive spindle speed · Excessive feed · Excessive long of effective length or overhang of end mill · Work piece is not firmly clamped · Wear of cutting edge progressed · Excessive chucking runout 	<ul style="list-style-type: none"> · Reduce spindle speed · Reduce feed · Adjust effective length and overhang as short as possible · Clamped work piece firmly · Use new end mill or regrind · Adjust chucking runout
Breakage of end mill	<ul style="list-style-type: none"> · Excessive depth of cut · Chips clogged · Excessive feed per tooth · Wear of cutting edge progressed 	<ul style="list-style-type: none"> · Reduce depth of cut · Adjust coolant nozzle to right direction to dispose chips · Reduce feed per tooth · Use new end mill or regrind
Chipping of cutting edge	<ul style="list-style-type: none"> · Excessive depth of cut · Excessive feed · Work piece is not firmly clamped · Excessive spindle speed · Excessive long of effective length or overhang of end mill · Wear of cutting edge progressed · Built up edge · Excessive cooling 	<ul style="list-style-type: none"> · Reduce depth of cut · Reduce feed · Clamped work piece firmly · Reduce spindle speed · Adjust effective length and overhang as short as possible · Use new end mill or regrind · Choose appropriate coating · Use air blow or oil mist
Abnormal wear	<ul style="list-style-type: none"> · Excessive spindle speed · Tool low feed 	<ul style="list-style-type: none"> · Reduce spindle speed · Increase feed
Clogging and Depositing	<ul style="list-style-type: none"> · Chips are not well disposed · Excessive feed · Excessive depth of cut · Inappropriate number of flute · Wear of cutting edge progressed 	<ul style="list-style-type: none"> · Adjust coolant nozzle to right direction to dispose chips · Reduce feed · Reduce depth of cut · Use fewer flutes end mill · Use new end mill or regrind
Deflection of end mill	<ul style="list-style-type: none"> · Excessive feed · Excessive depth of cut · Excessive long of effective length or overhang of end mill · Large helix angle of flutes 	<ul style="list-style-type: none"> · Reduce feed · Reduce depth of cut · Adjust effective length and overhang as short as possible · Use smaller helix angle
Burr on finished surface	<ul style="list-style-type: none"> · Wear of cutting edge progressed · Small helix angle of flutes · Excessive depth of cut 	<ul style="list-style-type: none"> · Use new end mill or regrind · Use smaller helix angle · Reduce depth of cut
Poor surface roughness	<ul style="list-style-type: none"> · Wear of cutting edge progressed · Chips bite · Excessive feed · Excessive long of effective length or overhang of end mill · Too low spindle speed · Stock removals vary for finishing · Excessive chucking runout 	<ul style="list-style-type: none"> · Use new end mill or regrind · Use coolant to remove chips · Reduce feed · Adjust effective length and overhang as short as possible · Increase spindle speed · Improve semi-finishing process · Adjust chucking runout
Poor machining accuracy	<ul style="list-style-type: none"> · Inconsistent thermal extension of spindle · Stock removals vary for finishing · Excessive feed · Excessive chucking runout 	<ul style="list-style-type: none"> · Warm up spindle by idling before starting operation · Improve semi-finishing process · Reduce feed · Adjust chucking runout