

FANUC Robot M-10iD 系列

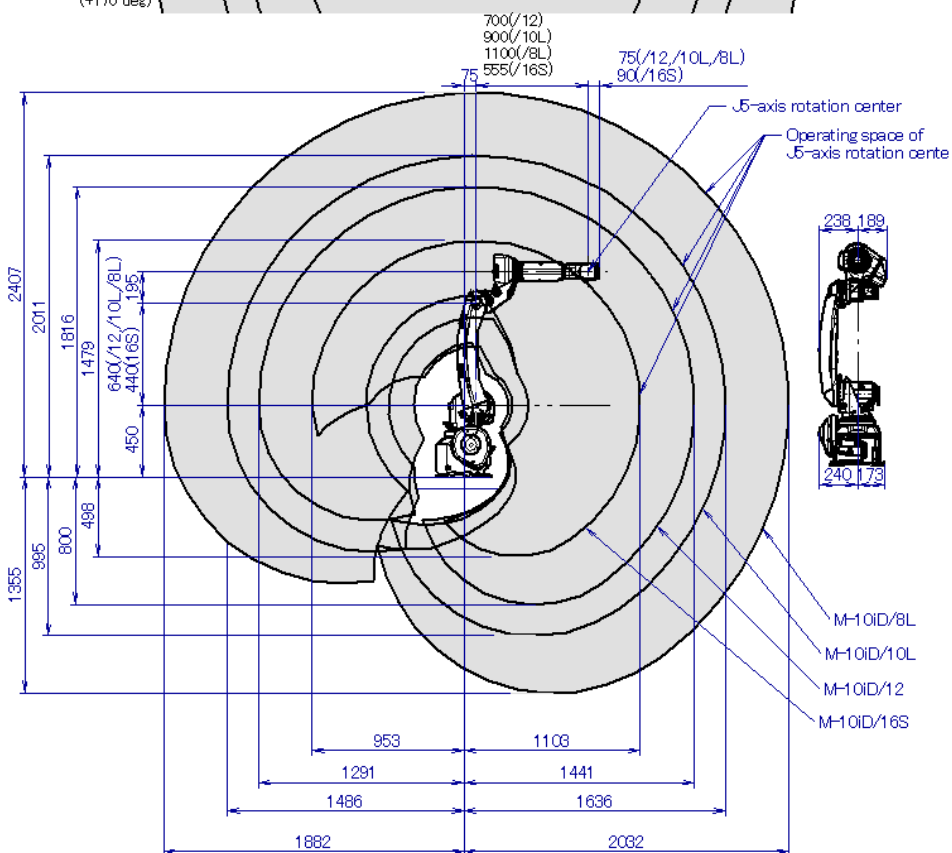

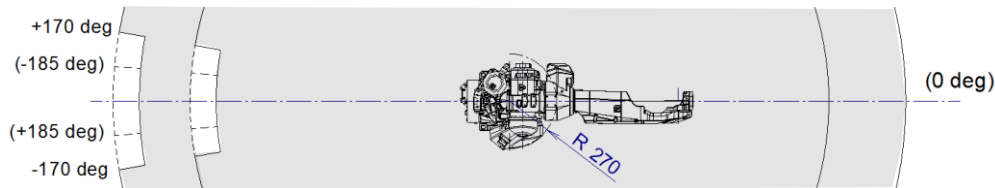

M-10iD系列

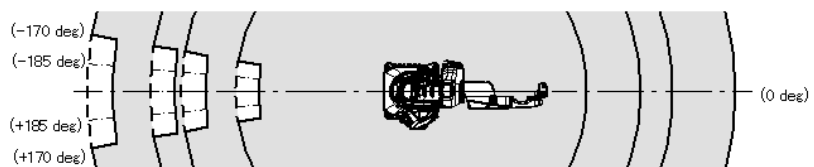
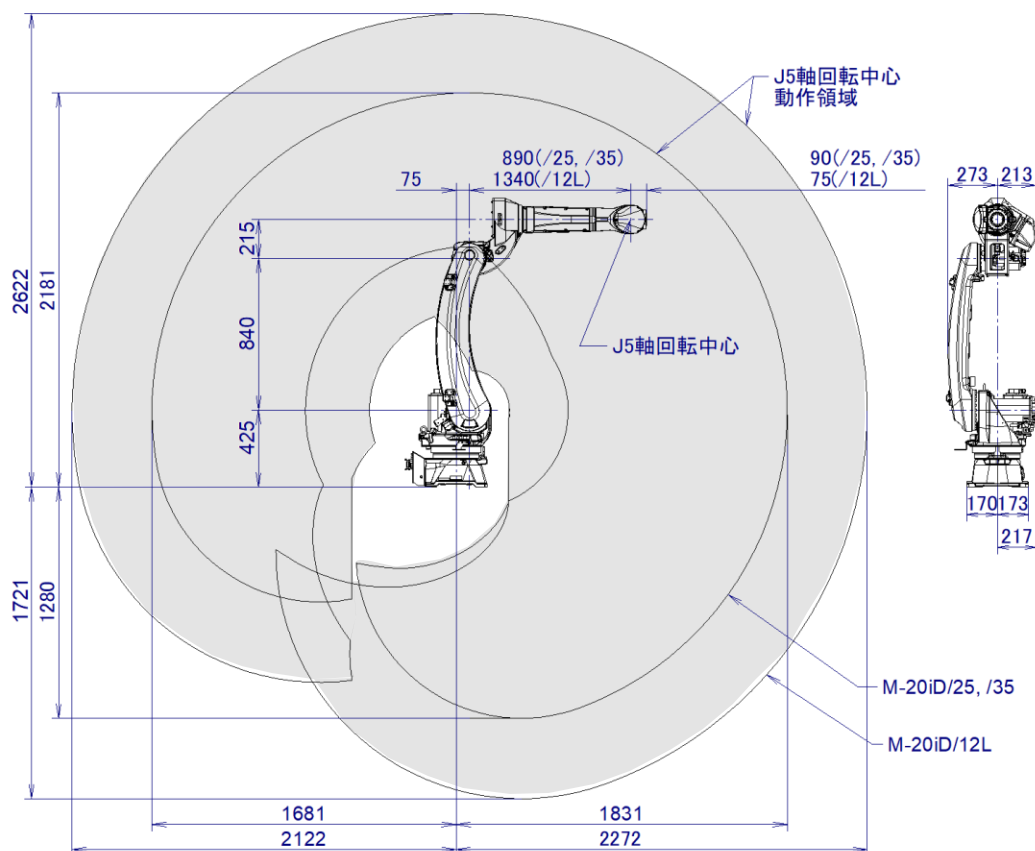

M-20iD系列

		M-10iD/12		M-10iD/10L	
Max. Speed [°/sec]	J1	260	Max. Speed [°/sec]	J1	260
	J2	240		J2	240
	J3	260		J3	260
	J4	430		J4	430
	J5	450		J5	450
	J6	720		J6	720
Wrist Payload / J3 Arm Load Capacity [kg]		12 / 12	Wrist Payload / J3 Arm Load Capacity [kg]		10 / 12
Wrist hollow diameter [mm]		57	Wrist hollow diameter [mm]		57
Wrist Moment [Nm] / Wrist Inertia [kgm ²]	J4	26.0 / 0.90	Wrist Moment [Nm] / Wrist Inertia [kgm ²]	J4	22.0 / 0.65
	J5	26.0 / 0.90		J5	22.0 / 0.65
	J6	11.0 / 0.30		J6	9.8 / 0.17
J1 reducer hollow diameter [mm]		108	J1 reducer hollow diameter [mm]		108
J2 interference radius [mm]		280	J2 interference radius [mm]		280
Welding hosepack & cable management		Fully Integrated	Welding hosepack & cable management		Fully Integrated
Reach [mm]		1441	Reach [mm]		1636
Stroke [mm]		1165	Stroke [mm]		1236
Repeatability [mm]		+/- 0.02	Repeatability [mm]		+/- 0.03
Weight [kg]		145	Weight [kg]		150
Acoustic noise level		57.4dB	Acoustic noise level		57.4dB

M-10iD, M-20iD Variant Model Lineup



ARC Mate 100iD/16S
(M-10iD/16S)

ARC Mate 100iD
(M-10iD/12)

ARC Mate 100iD/10L
(M-10iD/10L)

ARC Mate 100iD/8L
(M-10iD/8L)

ARC Mate 120iD
(M-20iD/25)

ARC Mate 120iD/35
(M-20iD/35)

ARC Mate 120iD/12L
(M-20iD/12L)

Payload 16kg
Reach 1103mm

Payload 12kg
Reach 1441mm

Payload 10kg
Reach 1636mm

Payload 8kg
Reach 2032mm

Payload 25kg
Reach 1831mm

Payload 35kg
Reach 1831mm

Payload 12kg
Reach 2272mm

多品項不需追加教導的3D散堆取出

FANUC Robot M-10iD/10L

特點

- 以3D視覺感測器3DV/600高速檢測出箱內隨機堆放的物件
- 以M-10iD/10L取出物件，放置於輸送帶排出
- 追加物件品項時，不需要追加設定教導
- 可自動避開箱內壁，避免干涉
- 利用真空感測器自行偵測取出成功/失敗，並重試
- 同一位置幾次失敗後，自動向內推倒，增加次回取出成功率

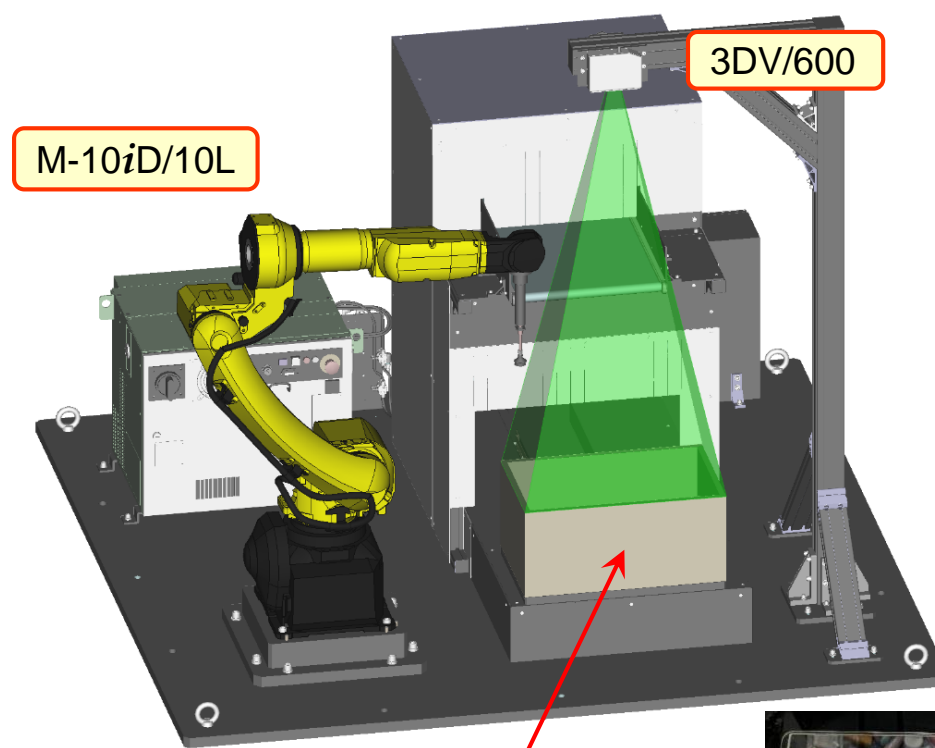

工件：各種日常用品隨機堆放
Various commodities

