

# COMPACT DOUBLE-LOCK VISE

## Model: CD-4"

**PATENTED**  
M461511  
M456255

- Designed with special device to hold 2 workpieces in different sizes (max. tolerance of 1.5mm) at the same time
- The combinations of jaws enable different clamping tasks, center fixed jaw can be removed for clamping larger work piece.
- Modular vise with fixed height, can be used vertically or horizontally
- Especially suitable for small CNC machining centers, several vises can be used on a machine table

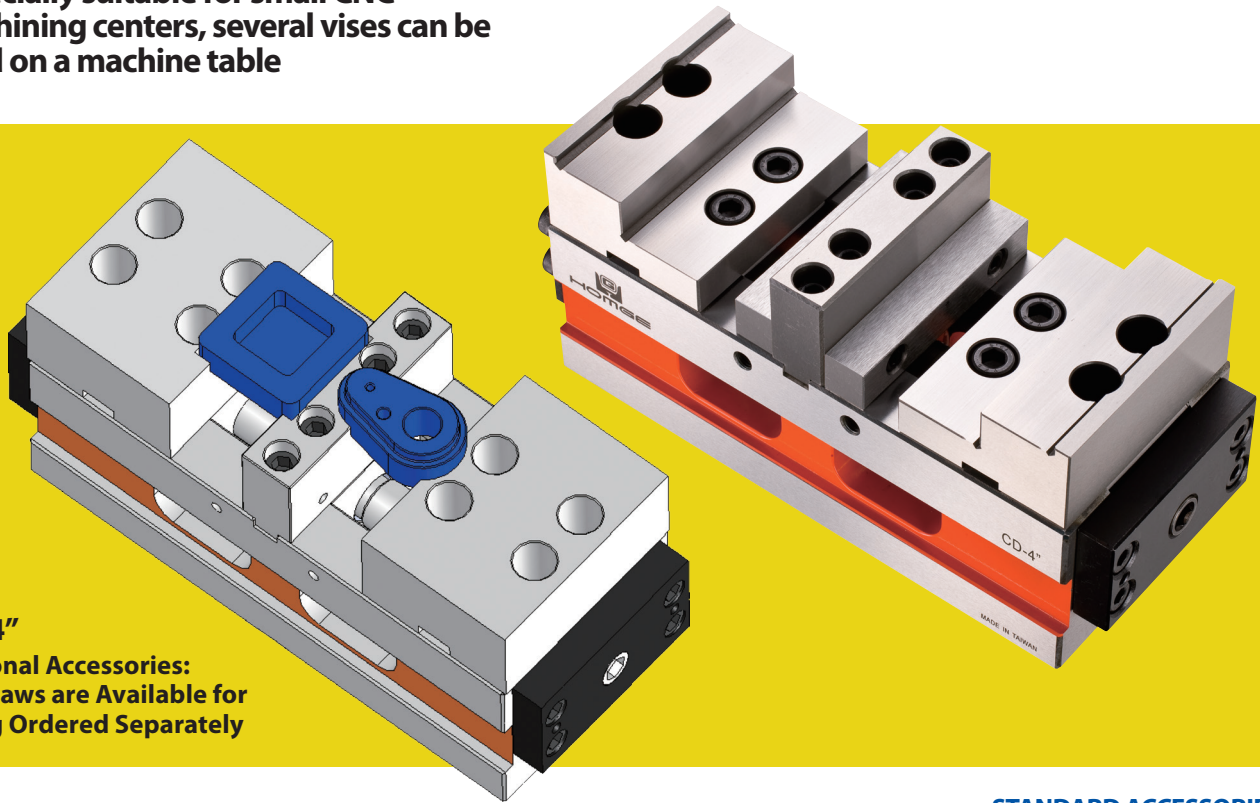

**CD-4"**  
Optional Accessories:  
Soft Jaws are Available for  
being Ordered Separately

**STANDARD ACCESSORIES:**

- 4 pcs of Clamp
- 1 pc of Wrench

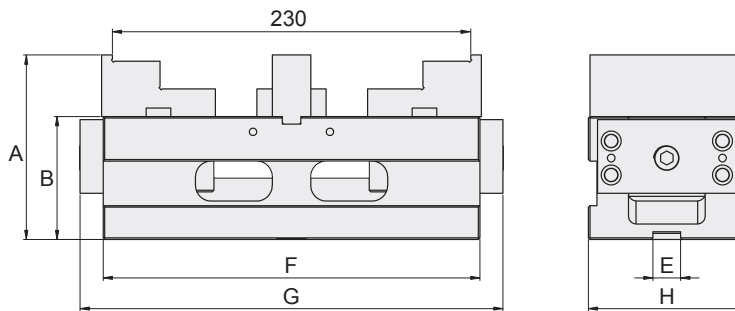

**SPECIFICATIONS** (Material: FCD 60 Ductile Iron. Hardness: HRC 50° / Material of Soft Jaw: Steel)

Unit: mm

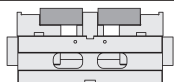
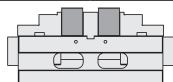
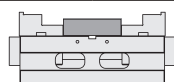
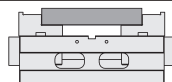
MODEL	A	B	E	F	G	H	Weight (kg)
CD-4"	120	80	18	245	275	102	18
MODEL	C		C1		C2	C3	
							
CD-4"	70		35		95	166	