

PGH SERIES

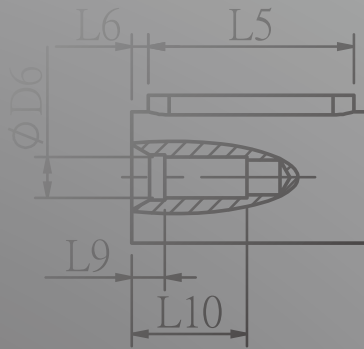

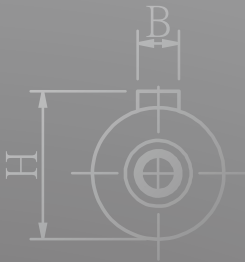

PGH60T/PGH90T/PGH115T/PGH142T/PGH180T

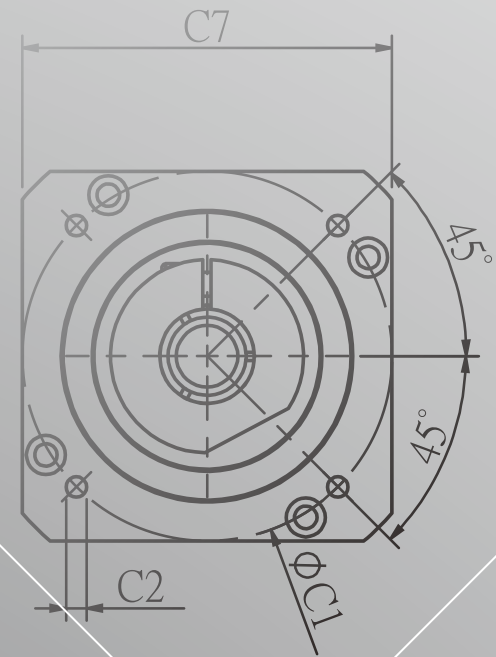
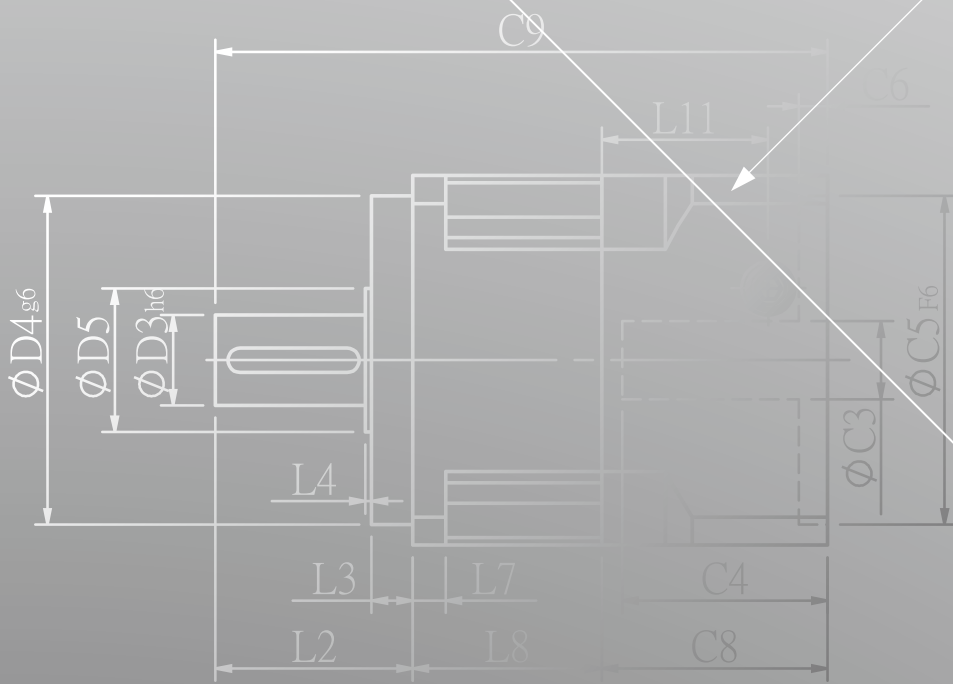
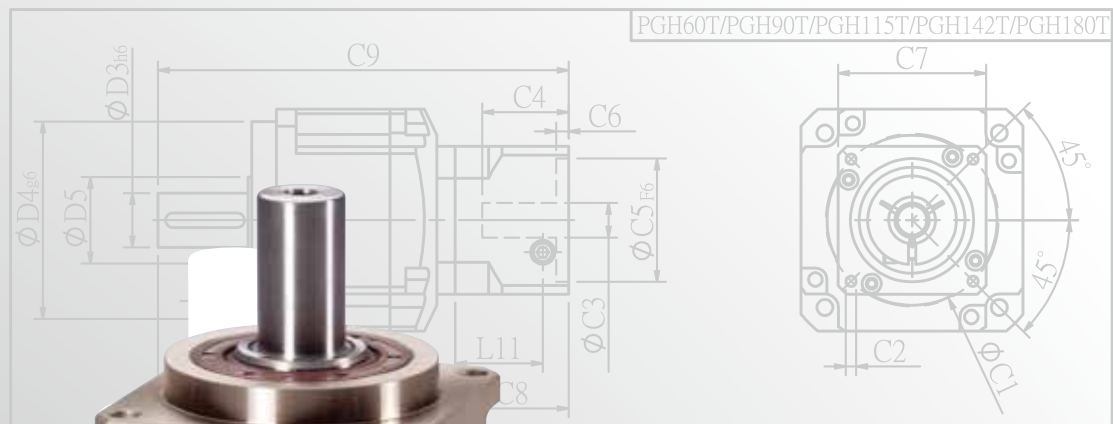
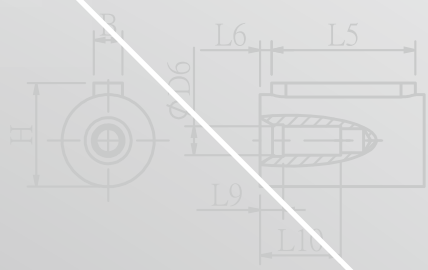
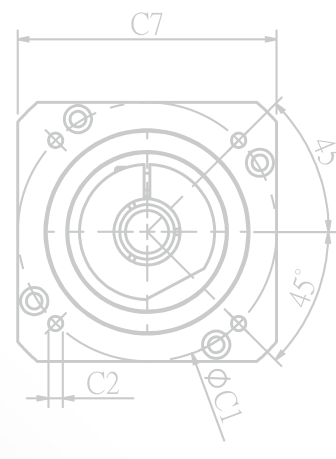
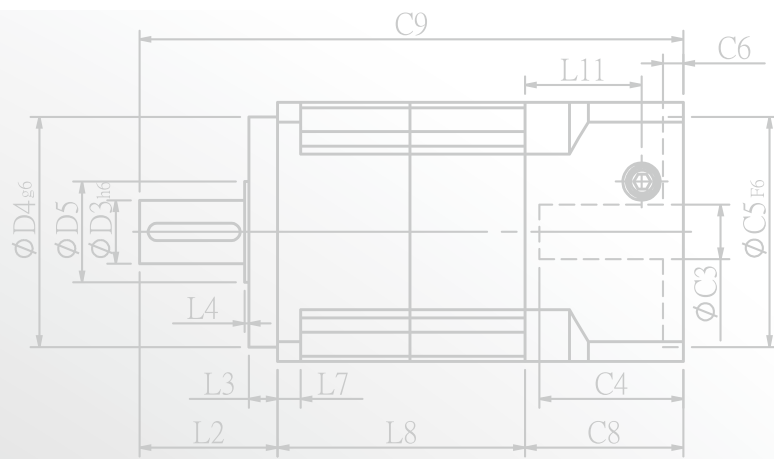

PGH Single Stage Dimensions

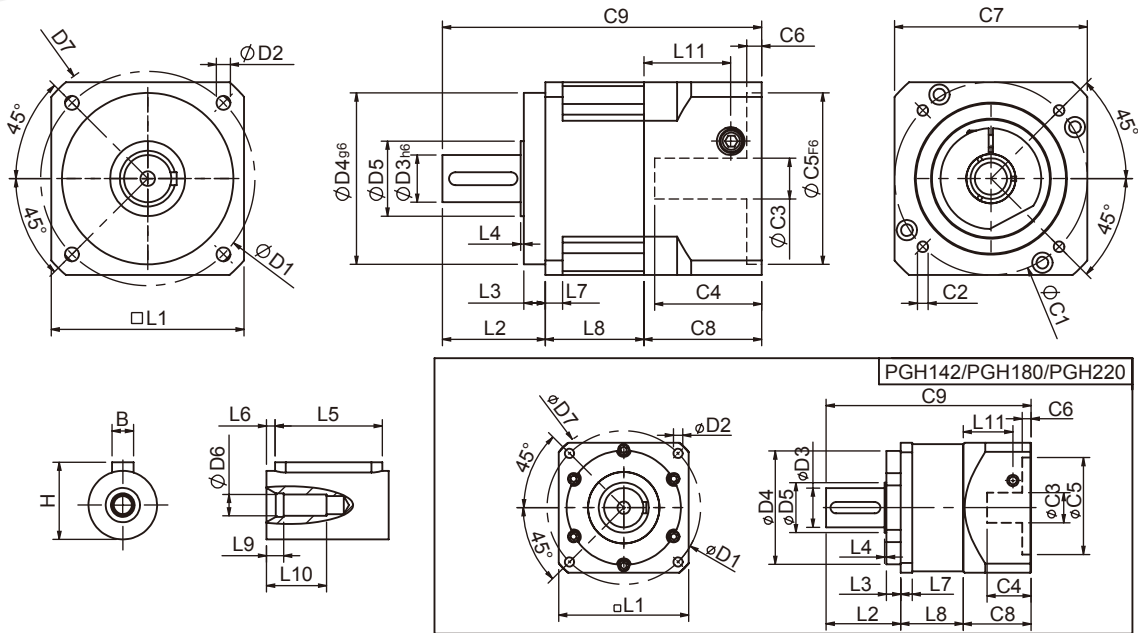

Specifications

Unit:mm

Dimensions	PGH42	PGH60	PGH90	PGH115	PGH142	PGH180	PGH220
D1	50	70	100	130	165	215	250
D2	3.4	5.5	6.5	8.5	10.5	13	17
D3 h6	13	16	22	32	40	55	75
D4 g6	35	50	80	110	130	160	180
D5	15	25	35	45	50	70	114.4
D6	M4x0.7P	M5x0.8P	M8x1.25P	M12x1.75P	M16x2.0P	M20x2.5P	M20x2.5P
D7	56	80	118	148	186	239	292
L1	42.6	60	90	115	142	182	220
L2	26	37	48	63	91.5	100.5	138
L3	5.5	7	10	10	10	16	30
L4	1	1.5	1.5	3.5	2.5	2.5	3
L5	15	25	32	40	60	70	90
L6	2	2	3	5	5	6	7
L7	4	6	8	11	16	18	20
L8	28.3	37	46	57	75.5	94	111
L9	4	4	4.5	6	6	8	15
L10	14	16.5	20.5	30	38	48	42
L11	29	35.5	40.5	42	63	69.5	96
C1 ²	46	70	90	115	145	200	235
C2 ²	M4x0.7P	M5x0.8P	M6x1.0P	M8x1.25P	M8x1.25P	M12x1.75P	M12x1.75P
C3 ²	≤8/≤11	≤14/≤19	≤19/≤24	≤24/≤32/≤38	≤35/≤38	≤50	≤55
C4 ²	27	37	47	56	66.5	82	112
C5 ² F6	30	50	70	95	110	114.3	200
C6 ²	4	4	6	10	6	13	6
C7 ²	42.6	60	90	115	140	180	220
C8 ²	38.5	46	55	63	80	95	120
C9 ²	92.8	120	149	183	247	289.5	369
B	5	5	6	10	12	16	20
H	15	18	24.5	35	43	59	79.5

★ C1~C9 are motor specific dimensions (metric std shown). Size may vary according to motor flange.

★ Specification subject to change without notice.

PGH Double Stage Dimensions-1

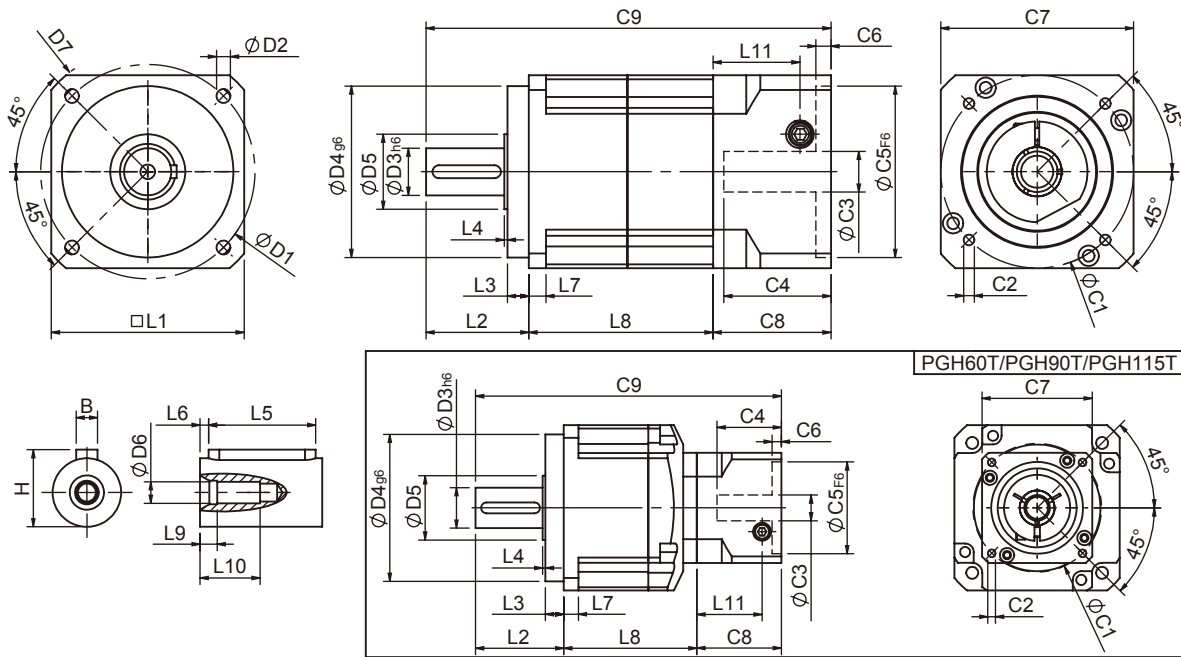

Specifications

Unit:mm

Dimensions	PGH42	PGH60	PGH60T	PGH90	PGH90T	PGH115T
D1	50	70		100		130
D2	3.4	5.5		6.5		8.5
D3 _{h6}	13	16		22		32
D4 _{g6}	35	50		80		110
D5	15	25		35		45
D6	M4x0.7P	M5x0.8P		M8x1.25P		M12x1.75P
D7	56	80		118		148
L1	42.6	60		90		115
L2	26	37		48		63
L3	5.5	7		10		10
L4	1	1.5		1.5		3.5
L5	15	25		32		40
L6	2	2		3		5
L7	4	6		8		11
L8	55.3	70	65.5	86	78.5	99.5
L9	4	4		4.5		6
L10	14	16.5		20.5		30
L11	29	35.5	29	40.5	35.5	40.5
C1 ²	46	70	46	90	70	90
C2 ²	M4x0.7P	M5x0.8P	M4x0.7P	M6x1.0P	M5x0.8P	M6x1.0P
C3 ²	≤8/≤11	≤14/≤19	≤8/≤11	≤19/≤24	≤14	≤19/≤24
C4 ²	27	37	27	47	37	47
C5 ² _{F6}	30	50	30	70	50	70
C6 ²	4	4	4	6	4	6
C7 ²	42.6	60	42.6	90	60	90
C8 ²	38.5	46	38.5	55	46	55
C9 ²	119.8	153	141	189	172.5	217.5
B	5	5		6		10
H	15	18		24.5		35

★ C1~C9 are motor specific dimensions (metric std shown). Size may vary according to motor flange.

★ Specification subject to change without notice.

PGH Double Stage Dimensions-2

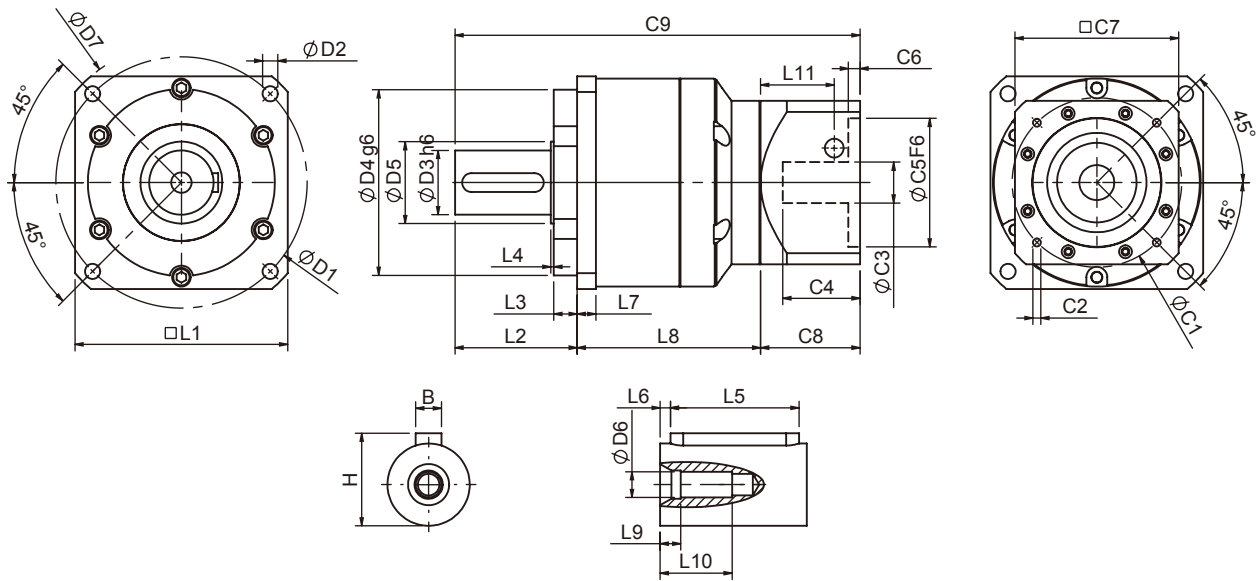

Specifications

Unit:mm

Dimensions	PGH142T	PGH180T	PGH220T
D1	165	215	250
D2	10.5	13	17
D3 _{h6}	40	55	75
D4 _{g6}	130	160	180
D5	50	70	114.4
D6	M16x2.0P	M20x2.5P	M20x1.5P
D7	186	239	292
L1	142	182	220
L2	91.5	100.5	138
L3	10	16	30
L4	2.5	2.5	3
L5	60	70	90
L6	5	6	7
L7	16	18	20
L8	127.5	166	202
L9	6	8	15
L10	38	48	42
L11	42	63	74
C1 ²	115	145	200
C2 ²	M8x1.25P	M8x1.25P	M12x1.75P
C3 ²	$\leq 24/\leq 32/\leq 38$	$\leq 35/\leq 38$	≤ 50
C4 ²	56	66.5	81
C5 ² _{F6}	95	110	114.3
C6 ²	10	6	6
C7 ²	115	140	180
C8 ²	63	80	93
C9 ²	282	346.5	433
B	12	16	20
H	43	59	79.5

★ C1~C9 are motor specific dimensions (metric std shown). Size may vary according to motor flange.

★ Specification subject to change without notice.

PGH Specifications Table

Specifications		Stage	Ratio	PGH-42	PGH-60	PGH-90	PGH-115	PGH-142	PGH-180	PGH-220	
Nominal Output Torque T_{2N}	N • m	1	3	19	53	145	290	520	950	1100	
			4	20	55	150	300	550	1050	1700	
			5	22	60	160	330	600	1200	2000	
			6	20	55	150	310	560	1100	1900	
			7	19	50	140	300	530	1100	1800	
			8	17	45	120	260	480	1000	1600	
			9	14	40	100	230	450	900	1500	
			10	14	40	100	230	450	900	1500	
			Stage	Ratio	PGH-42	PGH-60 (T)	PGH-90(T)	PGH-115T	PGH-142T	PGH-180T	PGH-220T
			15	19	53	145	290	520	950	2000	
		20	20	55	150	300	550	1050	2000		
		25	22	60	160	330	600	1200	2000		
		30	22	60	160	330	600	1200	2000		
		35	22	60	160	330	600	1200	2000		
		40	22	60	160	330	600	1200	2000		
		45	22	60	160	330	600	1200	2000		
		50	22	60	160	330	600	1200	2000		
		60	20	55	150	310	560	1100	1900		
		70	19	50	140	300	530	1100	1800		
		80	17	45	120	260	480	1000	1600		
90	14	40	100	230	450	900	1500				
100	14	40	100	230	450	900	1500				
Emergency Stop Torque T_{2NOT}	N • m	(3.0 times of Nominal Output Torque) (*Max. Output Torque T_{2B} = 60% of Emergency Stop Torque)									
Nominal Input Speed n_{1N}	rpm	1,2	3-100	5000	5000	4000	4000	3000	3000	2000	
Max. Input Speed n_{1max}	rpm	1,2	3-100	10000	10000	8000	8000	6000	6000	4000	
Micro Backlash P_0	arcmin	1	3-10	≤ 2	≤ 2	≤ 2	≤ 1	≤ 1	≤ 1	≤ 1	
		2	15-100	≤ 4	≤ 4	≤ 4	≤ 3	≤ 3	≤ 3	≤ 3	
Precision Backlash P_1	arcmin	1	3-10	≤ 4	≤ 4	≤ 4	≤ 3	≤ 3	≤ 3	≤ 3	
		2	15-100	≤ 6	≤ 6	≤ 6	≤ 5	≤ 5	≤ 5	≤ 5	
Standard Backlash P_2	arcmin	1	3-10	≤ 6	≤ 6	≤ 6	≤ 5	≤ 5	≤ 5	≤ 5	
		2	15-100	≤ 8	≤ 8	≤ 8	≤ 7	≤ 7	≤ 7	≤ 7	
Torsional Rigidity	N • m /arcmin	1,2	3-100	3	7	14	25	50	145	225	
Max. Radial Load F_{2rB}^1	N	1,2	3-100	760	1570	3250	6620	9400	14500	33000	
Max. Axial Load F_{2aB}^1	N	1,2	3-100	410	750	1870	3310	4670	6460	18530	
Operating Temp.	°C	-10 °C ~ +90 °C									
Service Life	hr	3-100 20,000 (10,000 Continuous operation)									
Efficiency	%	1	3-10	≥ 97%							
		2	15-100	≥ 94%							
Weight	kg	1	3-10	0.6	1.3	3.5	7.8	16.1	27	55	
		2	15-100	0.9	2.0/1.6	5.6/3.9	9.5	19	34	68.5	
Mounting Position	-	1,2	3-100	Any direction							
Noise Level ²	dBA/1m	1,2	3-100	56	58	60	63	65	67	70	
Protection Class	-	1,2	3-100	IP65							
Lubrication	-	1,2	3-100	Synthetic Lubricant							
Inertia (J1)											
Stage	Ratio	unit	PGH-42	PGH-60	PGH-90	PGH-115	PGH-142	PGH-180	PGH-220		
1	3	Kg • cm ²	0.03	0.23	0.97	2.35	10.00	30.50	79.50		
	4		0.02	0.18	0.67	1.66	7.17	25.86	58.21		
	5		0.02	0.17	0.65	1.50	6.52	23.63	54.36		
	6/7/8		0.02	0.14	0.60	1.45	6.17	22.92	54.12		
	9/10		0.02	0.14	0.58	1.41	6.10	22.73	53.98		
Stage	Ratio		PGH-42	PGH-60(T)	PGH-90(T)	PGH-115T	PGH-142T	PGH-180T	PGH-220T		
2	15/20/25		0.02	0.17(0.02)	0.65(0.17)	0.65	1.50	6.52	23.63		
	30/35/40		0.02	0.14(0.02)	0.60(0.14)	0.60	1.45	6.17	22.92		
	45/50/60/70/80/90/100		0.02	0.14(0.02)	0.58(0.14)	0.58	1.41	6.10	22.73		

* 1. Applied to the output shaft center at 100 rpm.

* 2. Measured at 3000 rpm with no load. These values are measured by gearbox with ratio = 10 (1-stage) or ratio = 100 (2-stage) at nominal input speed or 3000 rpm (if nominal input speed is higher than 3000 rpm) with no load.

※ The above figures/specifications are subject to change without prior notice.

Products due to human error, natural disasters or other factors lead to poor or damaged, will not be covered under warranty.