

# PGR SERIES

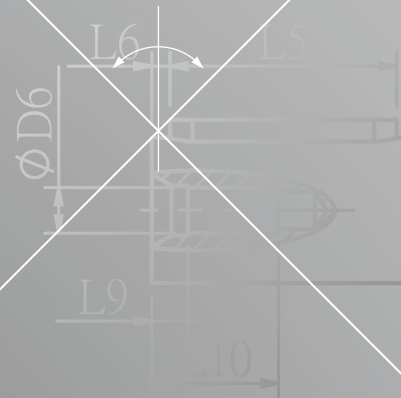

L8

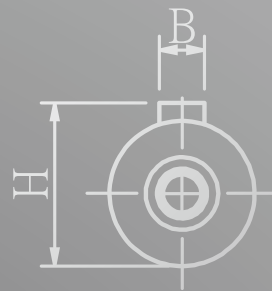
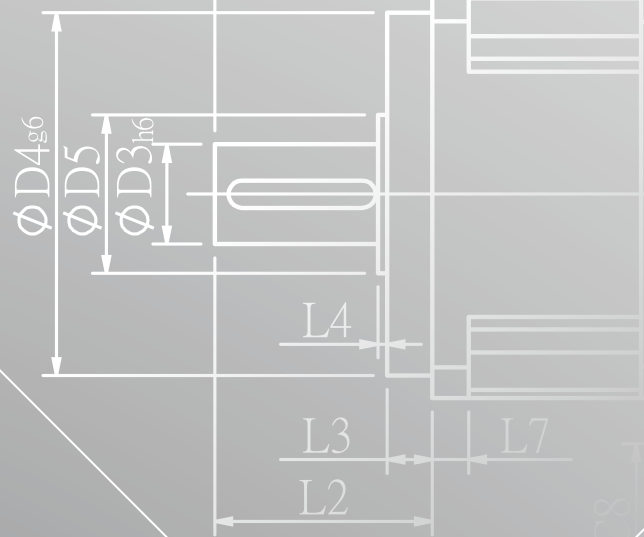
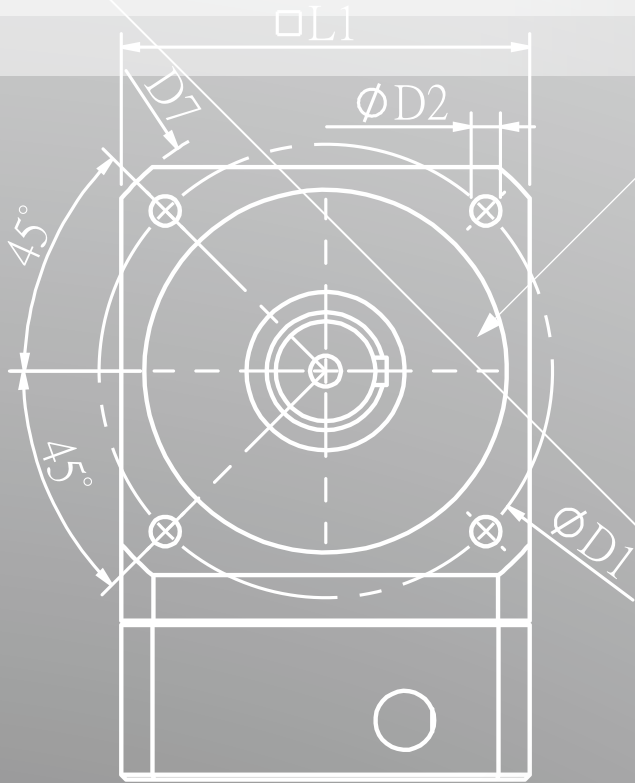
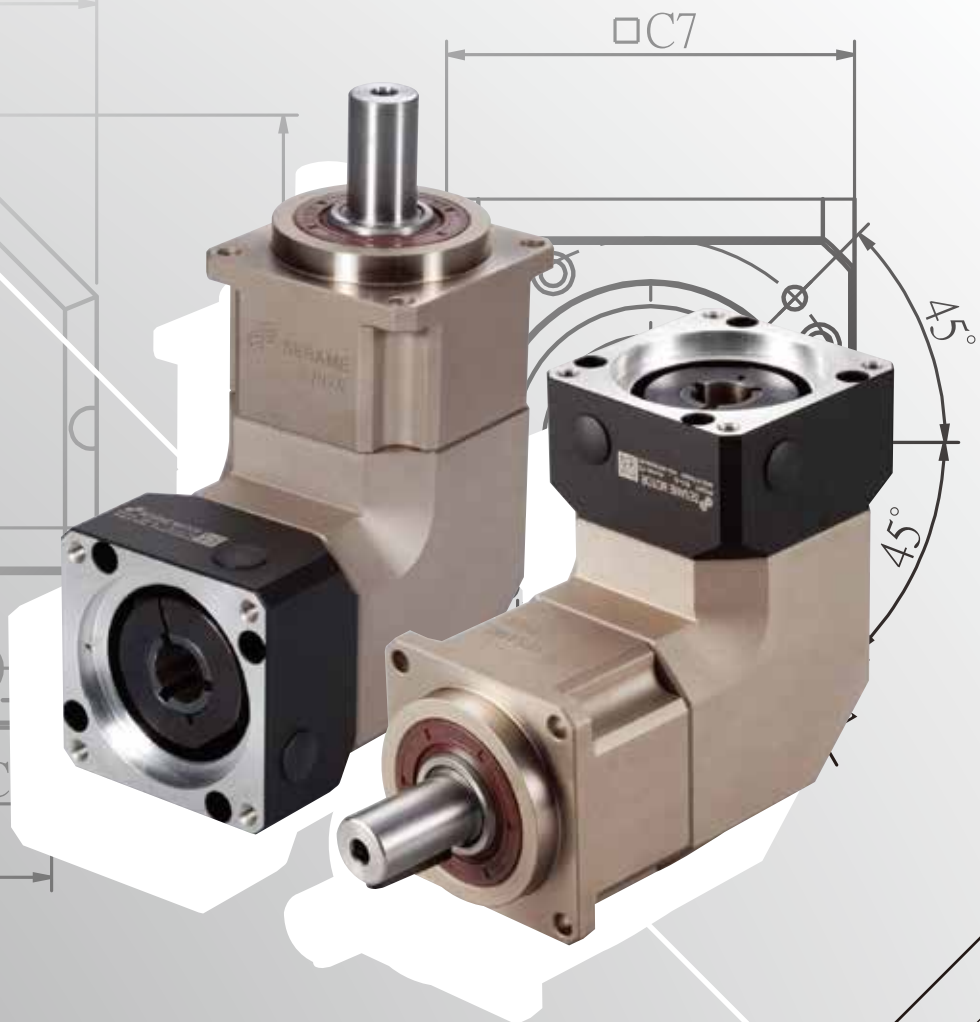

## PGR Single Stage Dimensions

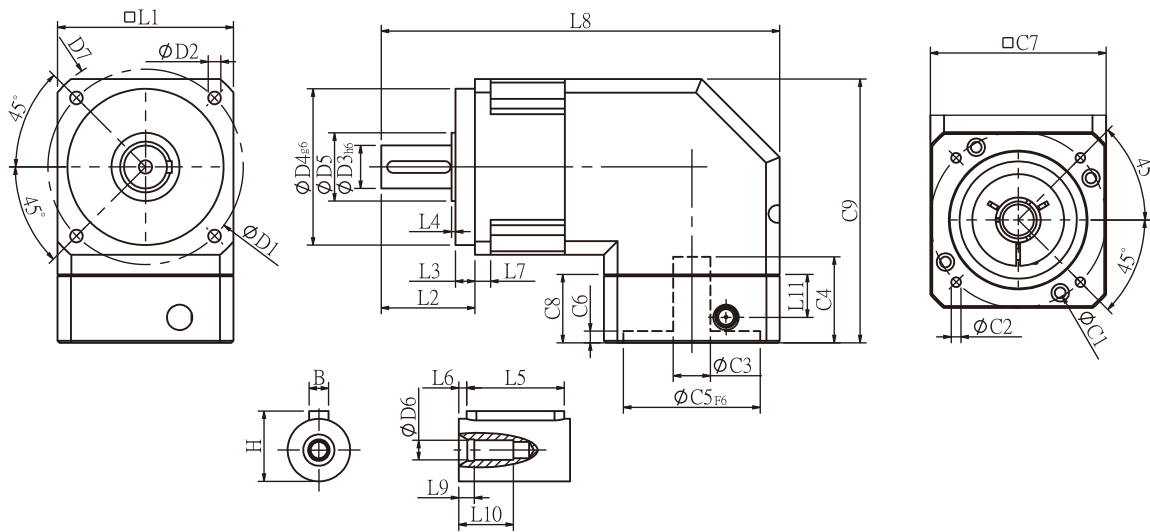

## Specifications

Unit:mm

Dimensions	PGR42	PGR60	PGR90	PGR115	PGR142
D1	50	70	100	130	165
D2	3.4	5.5	6.5	8.5	10.5
D3 <sub>h6</sub>	13	16	22	32	40
D4 <sub>g6</sub>	35	50	80	110	130
D5	15	25	35	45	50
D6	M4x0.7P	M5x0.8P	M8x1.25P	M12x1.75P	M16x2.0P
D7	56	80	118	148	186
L1	42.6	60	90	115	142
L2	26	37	48	62	93
L3	5.5	7	10	8	8
L4	1.5	1.5	1.5	3	6
L5	15	25	32	40	60
L6	2	2	3	5	5
L7	4	6	8	12	18
L8	103.6	148.7	204	244.5	330
L9	4	4	4.5	6	6
L10	14	16.5	20.5	30	38
L11	13.5	21.5	22	32	44.7
C1 <sup>2</sup>	46	70	90	115	145
C2 <sup>2</sup>	M4x0.7P	M5x0.8P	M6x1.0P	M8x1.25P	M8x1.25P
C3 <sup>2</sup>	$\leq 8 / \leq 11$	$\leq 14 / \leq 19$	$\leq 19 / \leq 24$	$\leq 24 / \leq 32$	$\leq 35$
C4 <sup>2</sup>	29	34	44	53	75
C5 <sup>2</sup> <sub>F6</sub>	30	50	70	95	110
C6 <sup>2</sup>	6	5	5	6	9
C7 <sup>2</sup>	42.6	60	90	115	140
C8 <sup>2</sup>	25	33	35	48	65
C9 <sup>2</sup>	70.8	107.8	135	174.5	207
B	5	5	6	10	12
H	15	18	24.5	35	43

★ C1~C9 are motor specific dimensions (metric std shown). Size may vary according to motor flange.

★ Specification subject to change without notice.

## PGR Double Stage Dimensions-1

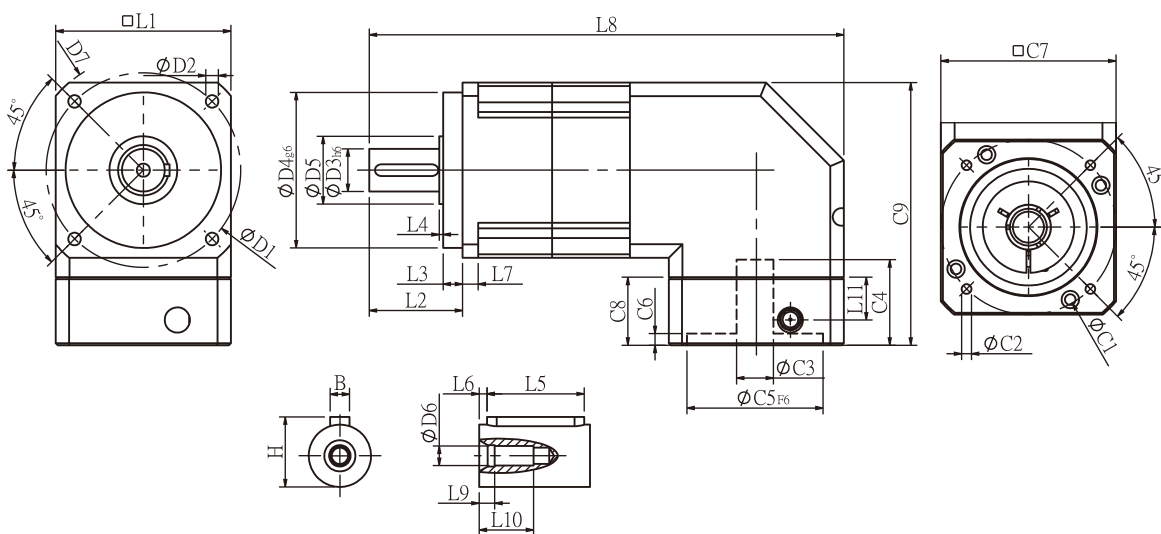

## Specifications

Unit:mm

Dimensions	PGR42	PGR60	PGR90	PGR115	PGR142
D1	50	70	100	130	165
D2	3.4	5.5	6.5	8.5	10.5
D3 <sub>h6</sub>	13	16	22	32	40
D4 <sub>g6</sub>	35	50	80	110	130
D5	15	25	35	45	50
D6	M4x0.7P	M5x0.8P	M8x1.25P	M12x1.75P	M16x2.0P
D7	56	80	118	148	186
L1	42.6	60	90	115	142
L2	26	37	48	62	93
L3	5.5	7	10	8	8
L4	1.5	1.5	1.5	3	6
L5	15	25	32	40	60
L6	2	2	3	5	5
L7	4	6	8	12	18
L8	129.6	176.7	244	292.5	391
L9	4	4	4.5	6	6
L10	14	16.5	20.5	30	38
L11	13.5	21.5	22	32	44.7
C1 <sup>2</sup>	46	70	90	115	145
C2 <sup>2</sup>	M4x0.7P	M5x0.8P	M6x1.0P	M8x1.25P	M8x1.25P
C3 <sup>2</sup>	≤8/≤11	≤14/≤19	≤19/≤24	≤24/≤32	≤35
C4 <sup>2</sup>	29	34	44	53	75
C5 <sup>2</sup> <sub>F6</sub>	30	50	70	95	110
C6 <sup>2</sup>	6	5	5	6	9
C7 <sup>2</sup>	42.6	60	90	115	140
C8 <sup>2</sup>	25	33	35	48	65
C9 <sup>2</sup>	70.8	107.8	135	174.5	207
B	5	5	6	10	12
H	15	18	24.5	35	43

★ C1~C9 are motor specific dimensions (metric std shown). Size may vary according to motor flange.

★ Specification subject to change without notice.

## PGR Double Stage Dimensions-2

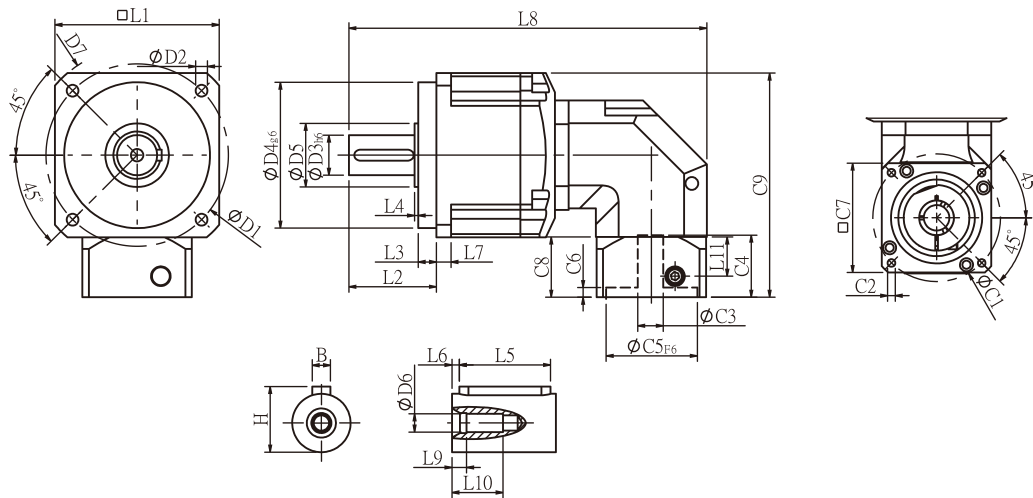

## Specifications

Unit:mm

Dimensions	PGR60T	PGR90T	PGR115T	PGR142T
D1	70	100	130	165
D2	5.5	6.5	8.5	10.5
D3 <sub>h6</sub>	16	22	32	40
D4 <sub>g6</sub>	50	80	110	130
D5	25	35	45	50
D6	M5x0.8P	M8x1.25P	M12x1.75P	M16x2.0P
D7	80	118	148	186
L1	60	90	115	142
L2	37	48	62	93
L3	7	10	8	8
L4	1.5	1.5	3	6
L5	25	32	40	60
L6	2	3	5	5
L7	6	8	12	18
L8	145.1	196.2	269.4	343.5
L9	4	4.5	6	6
L10	16.5	20.5	30	38
L11	13.5	21.5	22	32
C1 <sup>2</sup>	46	70	90	115
C2 <sup>2</sup>	M4x0.7P	M5x0.8P	M6x1.0P	M8x1.25P
C3 <sup>2</sup>	≤8/≤11	≤14/≤19	≤19/≤24	≤24/≤32
C4 <sup>2</sup>	29	34	44	53
C5 <sup>2</sup> <sub>F6</sub>	30	50	70	95
C6 <sup>2</sup>	6	5	5	6
C7 <sup>2</sup>	42.6	60	90	115
C8 <sup>2</sup>	25	33	35	48
C9 <sup>2</sup>	79.5	122.8	147.5	188
B	5	6	10	12
H	18	24.5	35	43

★ C1~C9 are motor specific dimensions (metric std shown). Size may vary according to motor flange.

★ Specification subject to change without notice.

## PGR Specifications Table

Specifications		Stage	Ratio	PGR-42	PGR-60	PGR-90	PGR-115	PGR-142	
Nominal Output Torque $T_{2N}$	N · m	1	3	13.8	35.3	76.2	220	380	
			4	11.9	35.9	74.6	249	450	
			5	13.8	43.0	95.2	283	473	
			6	12.5	39.4	90.9	220	420	
			7	11.9	36.0	85.6	219	400	
			8	10.9	32.4	85.0	216	363	
			9	9.8	28.7	80.0	210	320	
			10	13.8	43.0	95.2	260	473	
			Stage	Ratio	PGR-42	PGR-60 / 60T	PGR-90 / 90T	PGR-115 / 115T	PGR-142 / 142T
			2	15	13.8	44.2	95.2	283	482
		20		11.9	35.9	74.6	249	490	
		25		13.8	43.0	95.2	283	473	
		30		13.8	43.0	95.2	283	473	
		35		13.8	43.0	95.2	283	473	
		40		13.8	43.0	95.2	283	473	
		45		13.8	43.0	95.2	283	473	
		50		13.8	43.0	95.2	283	473	
		60		12.5	39.4	90.9	266	436	
		70		11.9	36.0	85.6	219	400	
		80	10.9	32.4	85.0	216	363		
90	9.8	28.7	80.0	210	320				
100	10.1	25.0	75.0	210	320				
Emergency Stop Torque $T_{2NOT}$	N · m		(3.0 times of Nominal Output Torque) (* Max. Output Torque $T_{2B}$ = 60% of Emergency Stop Torque)						
Nominal Input Speed $n_{1N}$	rpm	1,2	3-100	3000	3000	3000	2500	2000	
Max. Input Speed $n_{1max}$	rpm	1,2	3-100	6000	6000	6000	5000	4000	
Micro Backlash P0	arcmin	1	3-10	-	-	-	≤ 4	≤ 4	
		2	15-100	-	-	-	≤ 6	≤ 6	
Precision Backlash P1	arcmin	1	3-10	-	-	≤ 6	≤ 6	≤ 6	
		2	15-100	-	-	≤ 9	≤ 8	≤ 8	
Standard Backlash P2	arcmin	1	3-10	≤ 12	≤ 9	≤ 9	≤ 9	≤ 9	
		2	15-100	≤ 15	≤ 12	≤ 12	≤ 11	≤ 11	
Torsional Rigidity	N · m / arcmin	1,2	3-100	1.0	2.8	7.5	15.5	30	
Max. Radial Load $F_{2rB}^1$	N	1,2	3-100	350	960	1630	3380	6150	
Max. Axial Load $F_{2aB}^1$	N	1,2	3-100	320	900	1420	2930	5510	
Operating Temp.	°C		3-100	-10°C ~ +90°C					
Service Life	hr		3-100	20,000 (10,000 Continuous operation)					
Efficiency	%	1	3-10	≥ 94%					
		2	15-100	≥ 90%					
Weight	kg	1	3-10	1.0	2.5	6.5	13.2	24.6	
		2	15-100	1.3	3.2/2.8	8.6/6.9	17.7/14.5	29.7/26.2	
Mounting Position	-	1,2	3-100	Any direction					
Noise Level <sup>2</sup>	dB(A)/1m	1,2	3-100	65	67	70	70	75	
Protection Class	-	1,2	3-100	IP65					
Lubrication	-	1,2	3-100	Synthetic Lubricant					
Inertia (J1)									
Stage	Ratio	unit		PGR-42	PGR-60	PGR-90	PGR-115	PGR-142	
1	3/4/5/7/9	Kg · cm <sup>2</sup>		0.06	0.40	2.28	6.87	24.2	
	6/8/10			0.05	0.30	1.45	4.76	14.5	
Stage	Ratio			PGR-42	PGR-60(T)	PGR-90(T)	PGR-115(T)	PGR-142(T)	
2	15/20/25/35/45			0.06	0.40(0.08)	2.28(0.72)	6.87(3.02)	24.2(7.83)	
	others			0.05	0.30(0.06)	1.45(0.38)	4.76(1.64)	14.5(5.00)	

\* 1. Applied to the output shaft center at 100 rpm.  
\* 2. Measured at 3000 rpm with no load. These values are measured by gearbox with ratio = 10 (1-stage) or ratio = 100 (2-stage) at nominal input speed or 3000 rpm (if nominal input speed is higher than 3000 rpm) with no load.  
\* 3. PGR115T-□□-P0 is not applicable.  
※ The above figures/specifications are subject to change without prior notice.

Products due to human error, natural disasters or other factors lead to poor or damaged, will not be covered under warranty.

PHL PHFR PHF PGH PUR PUL PUA PGLH PGCH PGEH PGSH PGL PGC PGE SGC SGE PGRH PGR PGFR PGF PBC PBE PAE PAC PAN PGS PNS PGW