



www.bandsaw.com.tw



**鎂佳機械工業股份有限公司
MEGA MACHINE CO.,LTD.**

台灣 · 411014 台中市太平區工業路180號
No.180, Industrial Road, Tai-ping District, Taichung City, 411014, Taiwan R. O. C.
www.bandsaw.com.tw
Tel: +886-4-22712877 (Rep.) Fax: +886-4-22715016
E-Mail: sales@bandsaw.com.tw

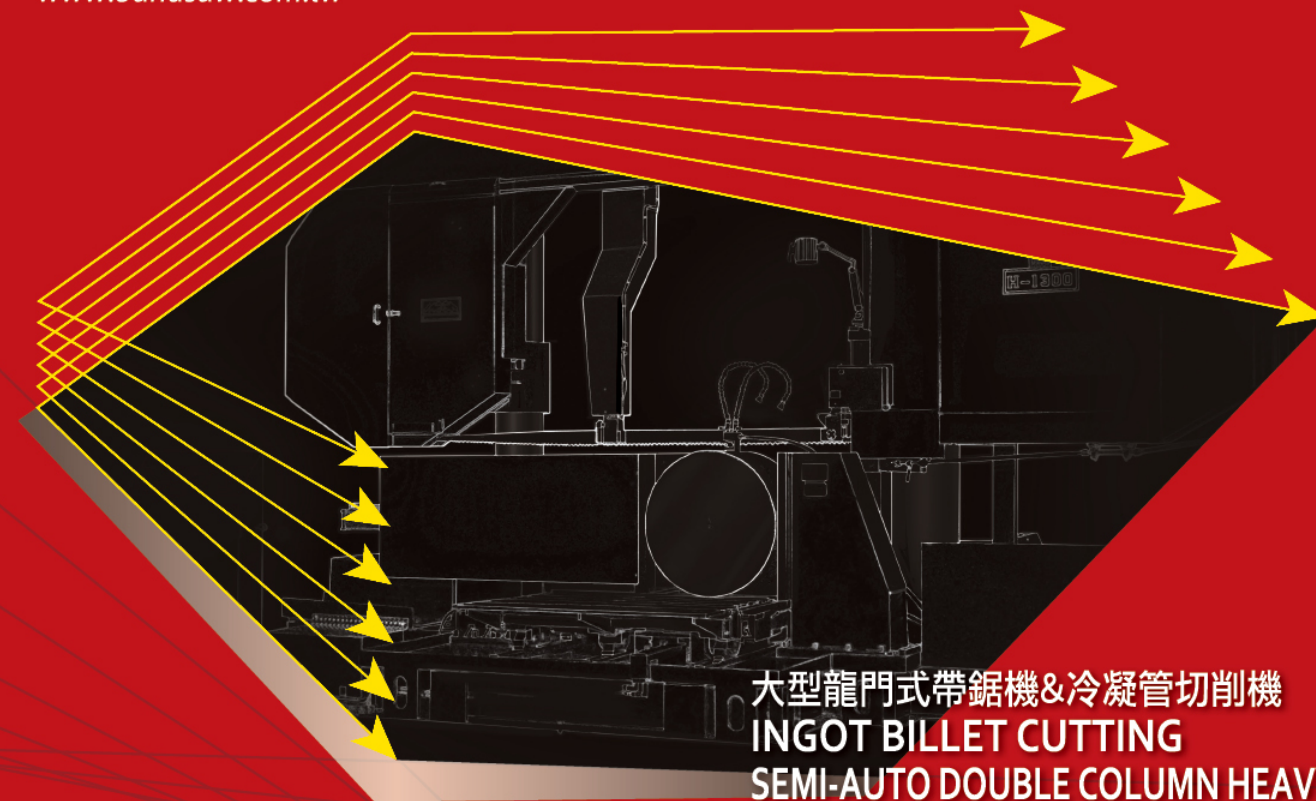

**大型龍門式帶鋸機&冷凝管切削機
INGOT BILLET CUTTING
SEMI-AUTO DOUBLE COLUMN HEAVY
DUTY HORIZONTAL BANDSAWS
& HEAT EXCHANGER PIPE/TUBE
CUTTING MACHINE**



Official Website

2015.04
886-4-2296-5959

*Keep Improving & Quality Oriented - Skillful engineering and imaginative design give every MEGA Band Saw Machine exceptional cutting capacity.
不斷創新與精進&嚴格執行品質要求-以操作者為出發點的設計,並追求完美的品質*

目錄 Directory

大型龍門式帶鋸機 INGOT BILLET CUTTING SEMI-AUTO DOUBLE COLUMN HEAVY DUTY HORIZONTAL BANDSAW	P3
H-800	P5
H-1080/H1100	P7
H-1300	P9
H-1613	P11
機台外觀尺寸 MACHINE DIMENSIONS	P13
冷凝管切削機 HEAT EXCHANGER PIPE/TUBE CUTTING MACHINE	P15
HCS-3000	P17

安全設計 – 每一鎂佳機械的帶鋸機皆有以下特點

SAFETY DESIGN- Every MEGA Band Saw is factory equipped with

1. 安全及熱過載開關 Safety and thermal overload switches.
2. 鋸帶及鋸輪安全保護蓋 Well guarded blades and wheel covers.
3. 切削完畢鋸帶自動停止 Saw Blade shuts off automatically when cutting is completed.
4. 低電壓及零電壓控制 Low voltage & zero voltage controls.
5. 鋸帶斷帶偵測 (半自動為選配) A blade breakage sensor/motion detector provides automatic shut-off. (Optional for manual/semi-auto models)



SINCE 1980



ISO9001



TUV Rheinland Approved

不斷創新與精進

今天做得要比昨天做得更好，明天做得要比今天做得還要好，是我們不斷創新，研究發展的精神所在。因為我們深知沒有成長就是退步，沒有創新就是落伍。鎂佳所以兢兢業業，奮發努力，為的是要提供經濟、完美的產品，貢獻業界來降低生產成本，減少胚料損失，提高生產能量，增進原胚料精度，提升自動化程度，促進技術升級，減少能源浪費。

嚴格執行品質要求

我們把機器當作是藝術品來處理，每個過程小心翼翼，要求盡善盡美，不容許有任何瑕疵。因為我們知道，為客戶提供完善快速的售後服務，不厭其煩的服務態度並不能使客戶完全滿足，唯有完美的品質，近乎免於服務的機器，才是我們追求的最大目標。

以操作者為出發點的設計

客戶的要求，操作者的願望，是本公司一系列帶鋸機設計的參考藍本，以機器來配合人們的操作，而不是以人來配合機器，正是我們全力追求的目標，因此，鎂佳的鋸床，結構剛強，操作容易，安全性高，鋸切能力強勁快速，精密度高，機件、鋸片持久耐用生產能量大，人工最省。

精良產品永續經營

鎂佳機械工業股份有限公司，創立於西元 1980 年，成立以全自動油壓帶鋸機、NC 全自動圓鋸機、精密油壓滾牙機、CNC 螺絲磨床之研發、製造、組裝及銷售服務的專業廠商。

KEEP IMPROVING

MEGA's R&D has over thirty-year experiences thus forms a strong team. It can provide total solution in screw and gear rolling, metal and nonferrous cutting, worm and thread grinding.

QUALITY ORIENTED

MEGA quality policy: "High performance and best quality can catch customers' heart, turning quality into company's "Super Salesman".

CUSTOMIZED FOR YOU

MEGA could provide total solution to meet your production requirement.

PERPETUAL MANAGEMENT

Since 1980, MEGA machine Co., Ltd has been specializing in designing, producing and assembling, serving customers with bandsaw machine, NC circular saw machine, thread rolling machine and CNC thread grinding machine.

隨研發的改進，本公司保有設計變更產品規格的權力與解釋權，確定規格、尺寸、產品資訊以實品為準，若有變更恕不另行通知。 Specifications are subject to change for improvement and modification without prior notice.

H 大型龍門式帶鋸機特色 FEATURES FOR INGOT BILLET CUTTING SEMI-AUTO DOUBLE COLUMN HEAVY DUTY HORIZONTAL BANDSAW



人機介面控制

1. 人性化觸控螢幕。
2. 簡易設定各項數值。
3. 多項安全偵測監控程式之設計，可顯示故障因素及維修對策。

TOUCH SCREEN CONTROL

1. Touch screen for easy operation.
2. Allowing easy presetting for various work-pieces.
3. Monitoring machine conditions and error messages display.



油壓鋸帶張力控制

鋸帶切削中張力自動被保持；當關機時，鋸帶張力自動放鬆，能增加鋸帶壽命。

HYDRAULIC BAND TENSION CONTROL

During operation of the saw the correct tension is automatically maintained. The tension is reduced when the saw is shut-off. This procedure greatly increases blade life.



鋸片旋轉偵測系統

此一裝置能保護鋸片於過負載切削時免於折損，因為過負載切削，鋸片會卡住於材料中，它能立即偵知停機，而避免繼續下降機台而折斷鋸片。另外，鋸片沒張緊或是意外折斷亦能自動停機。

IDLE WHEEL MOTION DETECTOR

The device not only can protect the saw blade from damage if the blade overloads/ jammed during cutting, but will also shut off the machine if the blade breaks.



導鋸油壓控制

導鋸座及導鋸支臂由油壓控制確保鋸帶精準並使鋸帶易於更換。

CARBIDE GUIDES WITH HYDRAULIC CONTROL

Carbide guides and guide arm are hydraulically operated ensure precise saw blade alignment, and easy operation for blade change.



動力鋼刷輪

動力鋼刷輪由強力冷卻液噴刷，確保鋸刃切削時無鐵屑。

POWER-DRIVEN SAW-BAND BRUSH

A power-driven saw-band brush, continually flushed by a cutting fluid spout, keeps the blade and saw guides free of chips for smoother cutting. A flush hose is available for washing chips and debris away from the cutting area.

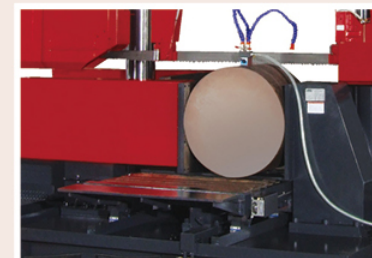

進料油壓活動夾鉗

機台前方有一油壓活動夾鉗用來進料及出料，此夾鉗在工件切削時可同時或分別與動力滾輪台（選配）作動。

HYDRAULIC SHUTTLE VISE FOR STOCK FEEDING

There is a hydraulic shuttle vise at the front of machine for loading and unloading of the work-piece. While positioning the work-piece for cutting, the shuttle vise can be operated simultaneously or separately with motorized roller table(opt.).



電動滾輪台（選配）

機台後方有用來進出料之馬達及鍊條滾輪台工件在切削時，馬達及鍊條滾輪台可同時或分別與油壓活動夾鉗作動。

MOTORIZED ROLLER TABLE(OPT.)

There is a motorized roller table at the rear side of the machine for loading and unloading of the work-piece. While positioning the work-piece for cutting, the motorized roller table can be operated simultaneously or separately with hydraulic shuttle vise.

H-800 大型龍門式帶鋸機 INGOT BILLET CUTTING

SEMI-AUTO DOUBLE COLUMN HEAVY DUTY HORIZONTAL BANDSAW

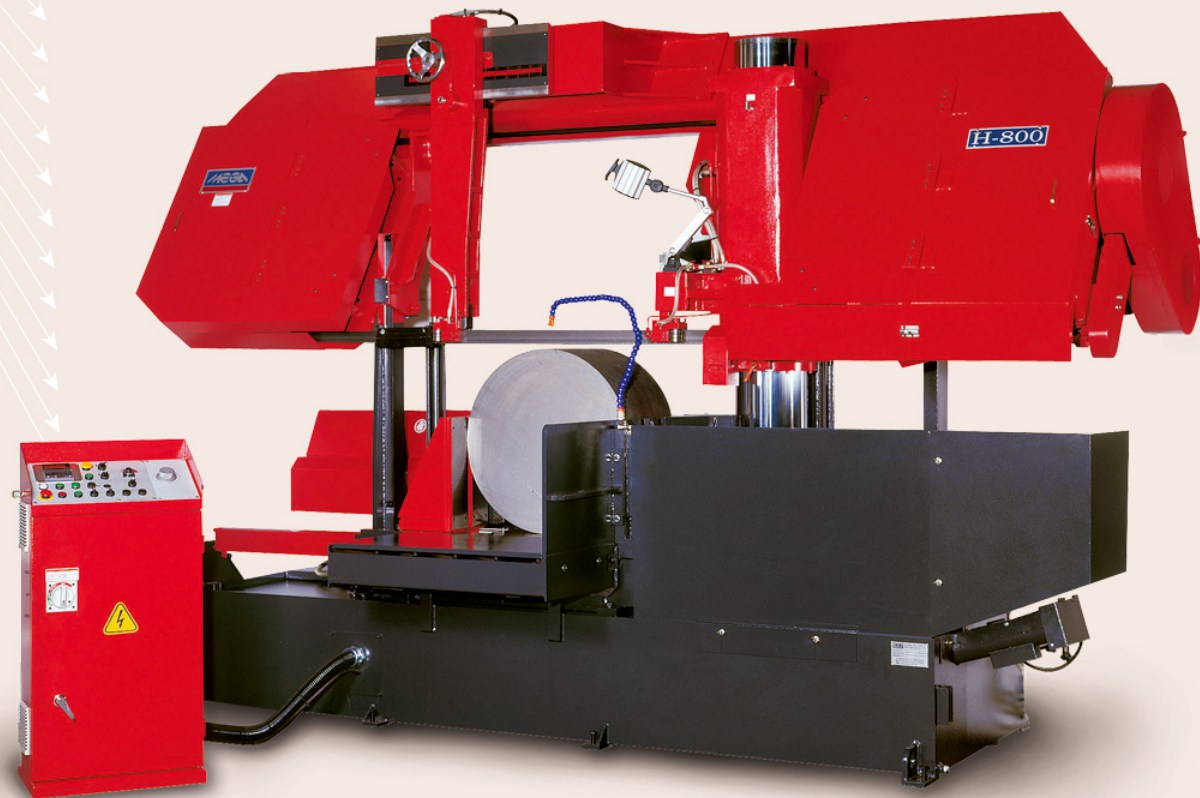

規格表 Specifications

規格 / 機型 SPEC. / MODEL	H-800	
鋸切能力 Cutting Capacity	mm	● 800 ■ 870W X 800H
	in	● 31.4 ■ 34.2W X 31.4H
鋸帶尺寸 Blade Size	mm	67W X 1.6t X 8800L
	in	2.64W X 0.063t X 346.46L
鋸帶速度 Blade Speed	M/min	無段變速 Variable Speed 15-70
	F/min	無段變速 Variable Speed 49-229
馬達 Motor Output	HP	鋸帶 Blade 15, 油壓 Hyd. 5, 冷卻 Coolant 1 / 4
	KW	鋸帶 Blade 11, 油壓 Hyd. 3.75, 冷卻 Coolant 0.19
封箱尺寸 (L X W X H) Shipping Volume	mm	4350 X 2270 X 2620
	ft	14.27 X 7.45 X 8.6
淨重 / 毛重 N.W. / G.W.	kg	8300 / 8900
	lb	18260 / 19580

標準配備 Standard Equipment

工具箱 Tools with tool box	1 只 set
清屑鋼刷輪 Band-cleaning wire brush	2 件 pcs
鋸帶 Bandsaw blade	1 條 pc
操作手冊與零件清單 Instruction manual and parts list	1 本 copy

選擇配備 Optional Equipment

1. 深度切削 Cutting depth control.
2. 1.5M(5ft) 長滾輪台 /3.3M(10ft) 動力滾輪台
1.5M(5ft) roller table /3.3M(10ft) motorized roller table.
3. 夾鉗壓力可調 Variable vise pressure system.
4. 自動清屑系統 Automatic chip conveyor.
5. 防傾斜裝置 Cutting deviation detecting system.

H-1080/1100 大型龍門式帶鋸機 INGOT BILLET CUTTING

SEMI-AUTO DOUBLE COLUMN HEAVY DUTY HORIZONTAL BANDSAW

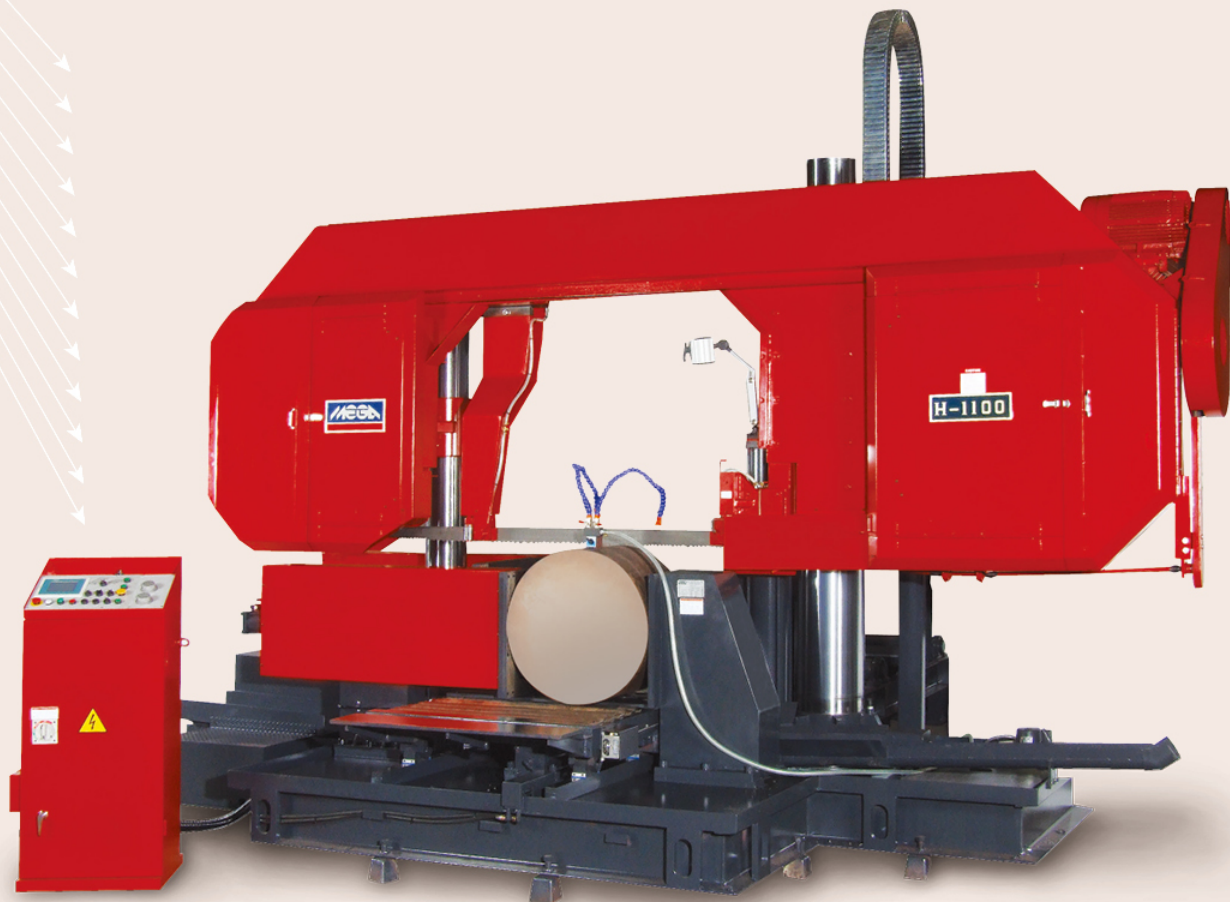

規格表 Specifications

規格 / 機型 SPEC. / MODEL	H-1080	H-1100
鋸切能力 Cutting Capacity	mm ● 800 ■ 1000W X 800H ■ 1000W X 1000H X 380L	● 1100 ■ 1100W X 1100H
	in ● 31.5 ■ 39.4W X 31.5H ■ 39.4W X 39.4H X 15L	● 43.3 ■ 43.3W X 43.3H
鋸帶尺寸 Blade Size	mm 67W X 1.6t X 8800L	80W X 1.6t X 10820L
	in 2.64W X 0.063t X 346.46L	3.15W X 0.063t X 425.98L
鋸帶速度 Blade Speed	M/min 無段變速 Variable Speed 12-60	無段變速 Variable Speed 12-60
	F/min 無段變速 Variable Speed 39-197	無段變速 Variable Speed 39-197
馬達 Motor Output	HP 鋸帶 Blade 15, 油壓 Hyd. 5, 冷卻 Coolant 1 / 4	鋸帶 Blade 15, 油壓 Hyd. 5, 冷卻 Coolant 1 / 4
	KW 鋸帶 Blade 11, 油壓 Hyd. 3.73, 冷卻 Coolant 0.19	鋸帶 Blade 11, 油壓 Hyd. 3.73, 冷卻 Coolant 0.19
封箱尺寸 (L X W X H) Shipping Volume	mm 4640 X 2270 X 3450	5460 x 2270 x 3560
	ft 15.22 X 7.45 X 11.32	19.13 X 7.05 X 12.37
淨重 / 毛重 N.W. / G.W.	kg 11500 / 12500	13500 / 14700
	lb 25300 / 27500	29700 / 32340

標準配備 Standard Equipment

工具箱 Tools with tool box	1 只 set
清屑鋼刷輪 Band-cleaning wire brush	2 件 pcs
鋸帶 Bandsaw blade	1 條 pc
操作手冊與零件清單 Instruction manual and parts list	1 本 copy

選擇配備 Optional Equipment

1. 深度切削 Cutting depth control.
2. 3.3M(10ft) 動力滾輪台 3.3M(10ft) motorized roller table.
3. 夾鉗壓力可調 Variable vise pressure system.
4. 自動清屑系統 Automatic chip conveyor.
5. 防傾斜裝置 Cutting deviation detecting system.

H-1300 大型龍門式帶鋸機 INGOT BILLET CUTTING

SEMI-AUTO DOUBLE COLUMN HEAVY DUTY HORIZONTAL BANDSAW

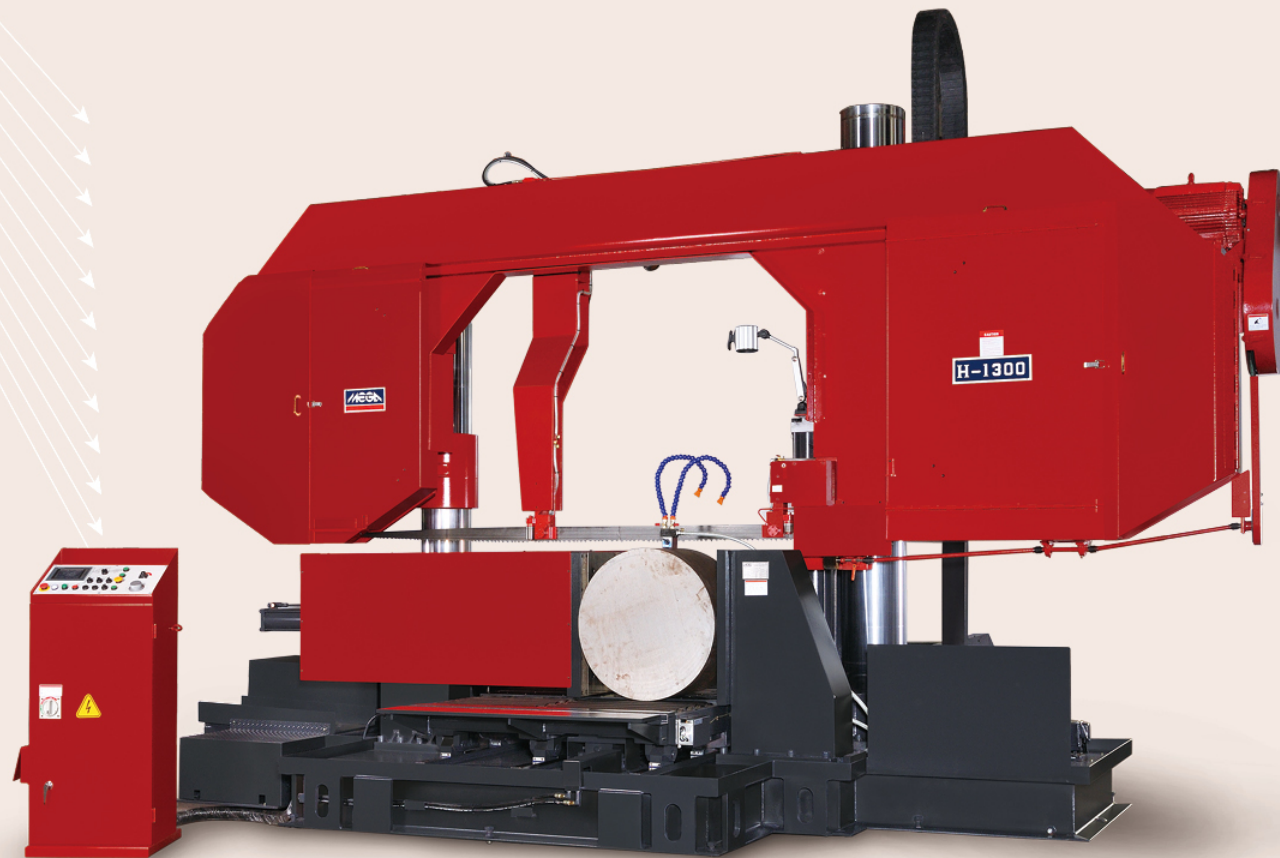

規格表 Specifications

規格 / 機型 SPEC. / MODEL	H-1300	
鋸切能力 Cutting Capacity	mm	● 1300 ■ 1300W X 1300H
	in	● 51.2 ■ 51.2W X 51.2H
鋸帶尺寸 Blade Size	mm	80W X 1.6t X 12300L
	in	3.15W X 0.063t X 484.25L
鋸帶速度 Blade Speed	M/min	無段變速 Variable Speed 12-60
	F/min	無段變速 Variable Speed 39-197
馬達 Motor Output	HP	鋸帶 Blade 20, 油壓 Hyd. 5, 冷卻 Coolant 1 / 4
	KW	鋸帶 Blade 15, 油壓 Hyd. 3.73, 冷卻 Coolant 0.19
封箱尺寸 (L X W X H) Shipping Volume	mm	5830 X 2150 X 3770
	ft	19.13 X 7.05 X 12.37
淨重 / 毛重 N.W. / G.W.	kg	16000 / 17500
	lb	35200 / 38500

標準配備 Standard Equipment

工具箱 Tools with tool box	1 只 set
清屑鋼刷輪 Band-cleaning wire brush	2 件 pcs
鋸帶 Bandsaw blade	1 條 pc
操作手冊與零件清單 Instruction manual and parts list	1 本 copy

選擇配備 Optional Equipment

1. 深度切削 Cutting depth control.
2. 3.3M(10ft) 動力滾輪台 3.3M(10ft) motorized roller table.
3. 夾鉗壓力可調 Variable vise pressure system.
4. 自動清屑系統 Automatic chip conveyor.
5. 防傾斜裝置 Cutting deviation detecting system.

H-1613 大型龍門式帶鋸機 INGOT BILLET CUTTING

SEMI-AUTO DOUBLE COLUMN HEAVY DUTY HORIZONTAL BANDSAW

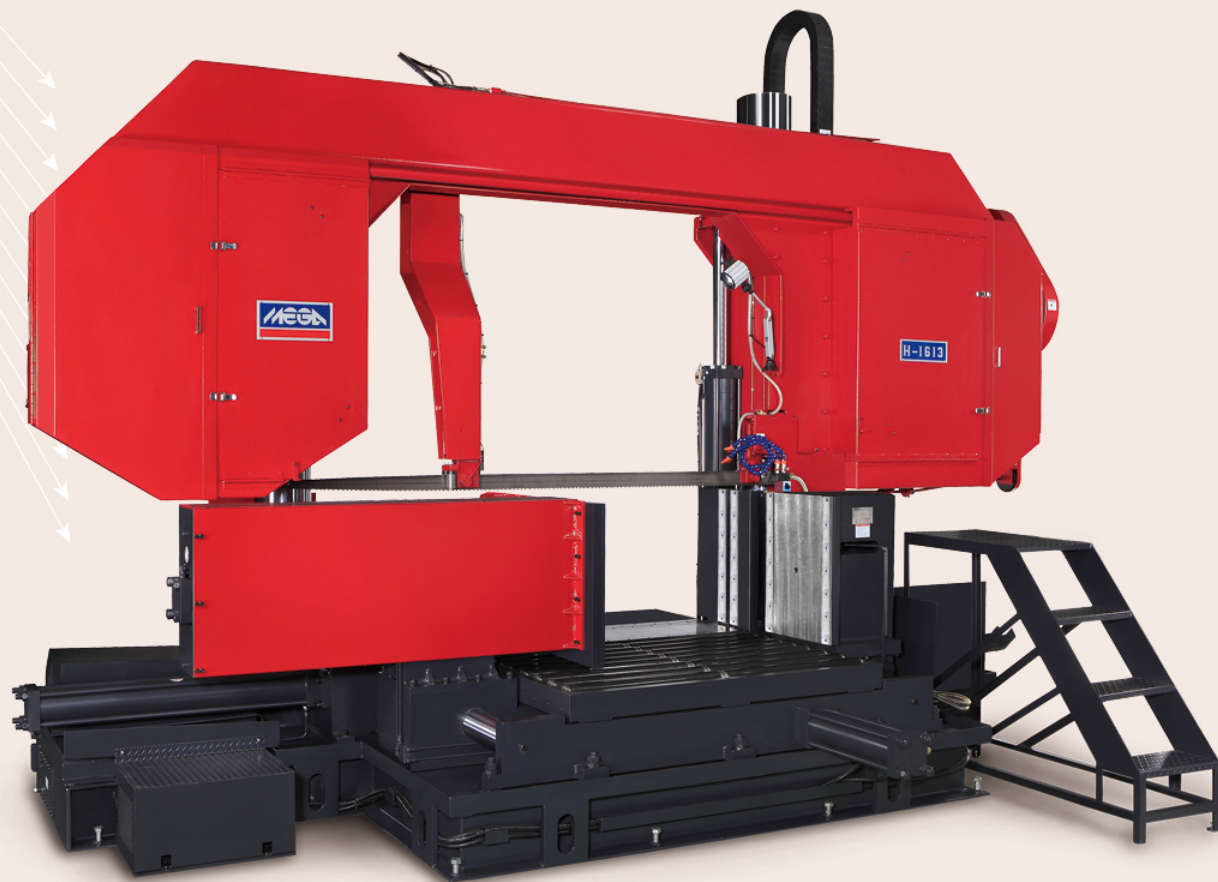

規格表 Specifications

規格 / 機型 SPEC. / MODEL	H-1613	
鋸切能力 Cutting Capacity	mm	● 1300 ■ 1600W X 1300H
	in	● 51.2 ■ 63W X 51.2 H
鋸帶尺寸 Blade Size	mm	80W X 1.6t X 12900L
	in	3.15W X 0.063t X 507.87L
鋸帶速度 Blade Speed	M/min	無段變速 Variable Speed 12-60
	F/min	無段變速 Variable Speed 39-197
馬達 Motor Output	HP	鋸帶 Blade 20, 油壓 Hyd. 5, 冷卻 Coolant 1 / 4
	KW	鋸帶 Blade 15, 油壓 Hyd. 3.73, 冷卻 Coolant 0.19
封箱尺寸 (L X W X H) Shipping Volume	mm	6300 X 2900 X 3900
	ft	20.67 X 9.51 X 12.8
淨重 / 毛重 N.W. / G.W.	kg	20300 / 21800
	lb	44660 / 47960

標準配備 Standard Equipment

工具箱 Tools with tool box	1 只 set
清屑鋼刷輪 Band-cleaning wire brush	2 件 pcs
鋸帶 Bandsaw blade	1 條 pc
操作手冊與零件清單 Instruction manual and parts list	1 本 copy

選擇配備 Optional Equipment

1. 深度切削 Cutting depth control.
2. 3.3M(10ft) 動力滾輪台 3.3M(10ft) motorized roller table.
3. 夾鉗壓力可調 Variable vise pressure system.
4. 自動清屑系統 Automatic chip conveyor.
5. 防傾斜裝置 Cutting deviation detecting system.

H-800 大型龍門式帶鋸機 INGOT BILLET CUTTING

SEMI-AUTO DOUBLE COLUMN HEAVY DUTY HORIZONTAL BANDSAW

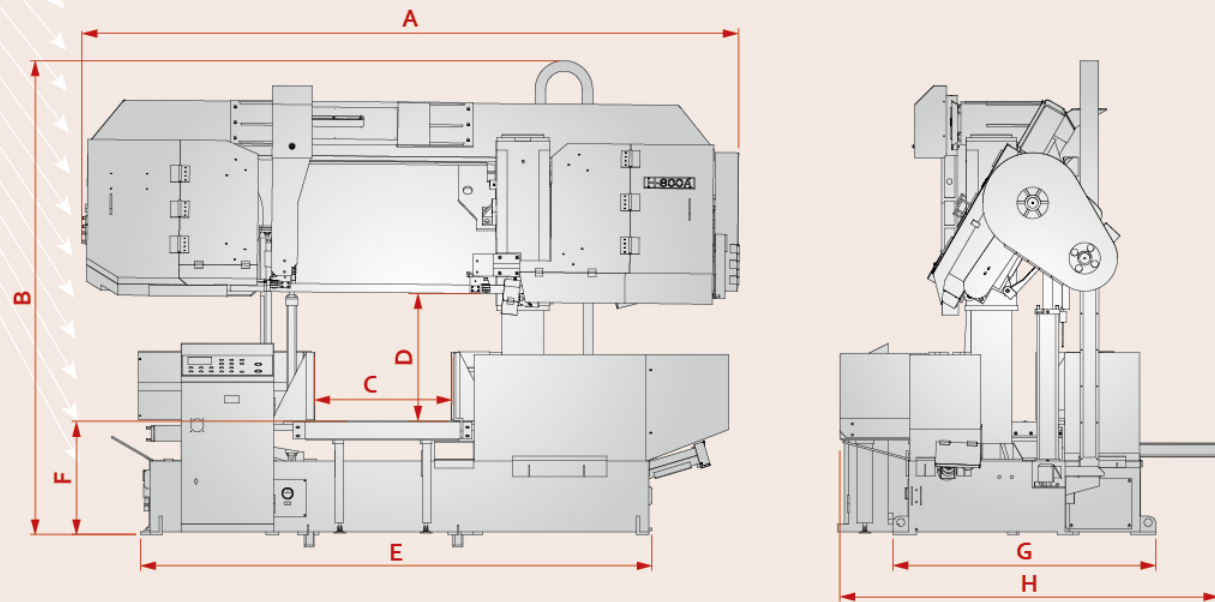

機型 MODEL / 規格 SPEC.	單位 UNIT	A	B	C	D	E	F	G	H
H-800	mm	4197	3025	880	815	3270	722	1971	2421
	inch	165.2	119.1	34.6	32.1	128.7	28.4	77.6	95.3

H-1080/1100/1300/1613

大型龍門式帶鋸機 INGOT BILLET CUTTING

SEMI-AUTO DOUBLE COLUMN HEAVY DUTY HORIZONTAL BANDSAW

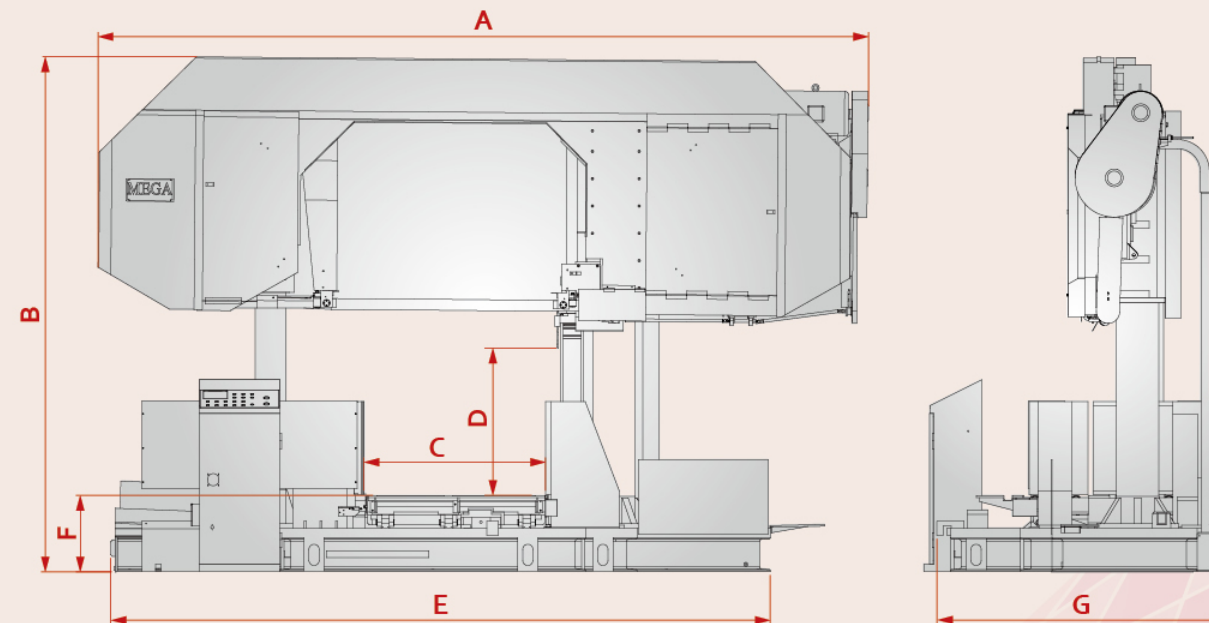

機型 MODEL / 規格 SPEC.	單位 UNIT	A	B	C	D	E	F	G
H-1080	mm	4199	3062	1035	1040	3883	577	2165
	inch	165.3	120.6	40.7	40.9	152.9	22.7	85.2
H-1100	mm	5031	3398	1115	1140	4467	595	2057
	inch	198.1	133.8	43.9	44.9	175.9	23.4	81
H-1300	mm	5634	3732	1325	1335	4861	554	2152
	inch	221.8	146.9	52.2	52.6	191.4	21.8	84.7
H-1613	mm	5945	3757	1620	1340	5161	552	2019
	inch	234.1	147.9	63.8	52.8	203.2	21.7	79.5

HCS 冷凝管切削機

HEAT EXCHANGER PIPE/TUBE CUTTING MACHINE



本機特色 Feature

1. 人機控制 Touch screen control.
2. 變頻無段變速 Variable speed drive.
3. 伺服進刀 Servo motor feedrate.
4. 油霧式冷卻系統 Oil mist cooling system.
5. 無底座機台設計較不占空間 Compact design takes less space.
6. 工件最大可切到外徑 3 米 Able to cut work-piece up to 3000mm(OD).

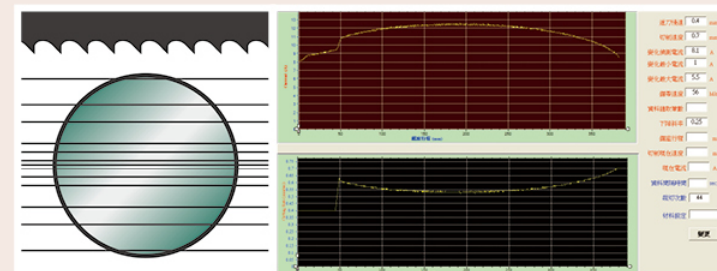

可切外徑達 3000mm 之工件
Able to cut work-piece up to 3000mm(OD)



冷凝管切削工廠實景
Cutting heat exchanger pipe

HCS-3000 冷凝管切削機

HEAT EXCHANGER PIPE/TUBE CUTTING MACHINE

規格表 Specifications

規格 / 機型 SPEC. / MODEL	HCS-3000	
鋸切能力 Cutting Capacity	mm	◎ 1300-3000 X 650L
	in	◎ 51.2-118.1 X 25.5L
鋸帶尺寸 Blade Size	mm	67W X 1.6t X 10530L
	in	2.6W X 0.06t X 414.57L
鋸帶速度 Blade Speed	M/min	無段變速 Variable Speed 20-80
	F/min	無段變速 Variable Speed 0.7-3.15
總馬達馬力 Motor Output	HP	進刀伺服馬達 Servo Feedrate 10HP 鋸帶 Blade 7.5HP8P, 油壓 Hyd.5HP4P
	KW	進刀伺服馬達 Servo Feedrate 7.5KW 鋸帶 Blade 5.6KW8P, 油壓 Hyd.3.7KW4P
淨重 / 毛重 N.W. / G.W.	kg	9000 / 10800
	lb	19800 / 23760

標準配備 Standard Equipment

附屬工具與工具箱 Tools with tool box	1 個 set
清刷輪 Band-cleaning wire brush	2 個 pcs
操作手冊 Instructions manual and parts list	1 本 copy
冷卻油噴霧油罐系統 Oil mist cooling system	1 個 set

選擇配備 Optional Equipment

1. 深度切削 Cutting depth control.

機台外觀尺寸 MACHINE DIMENSIONS

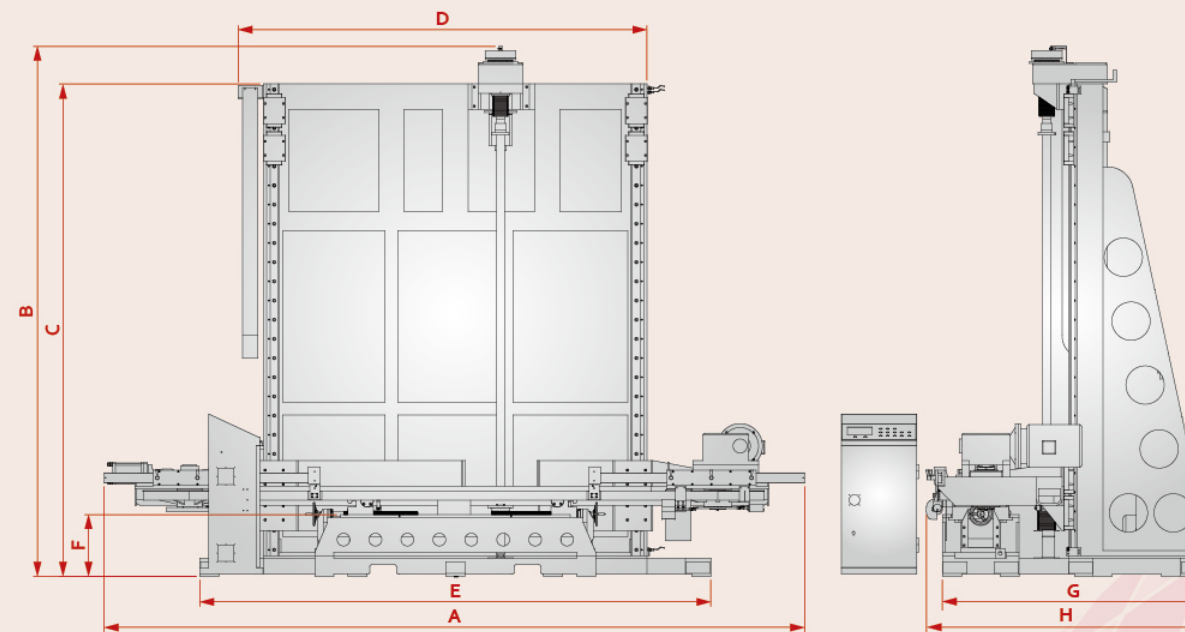

機型 MODEL / 規格 SPEC.	單位 UNIT	A	B	C	D	E	F	G	H
HCS-3000	mm	5482	4144	3851	3200	4000	481	2057	2182
	inch	215.8	163.1	151.6	126	157.5	18.9	81	85.9