

PGH SERIES

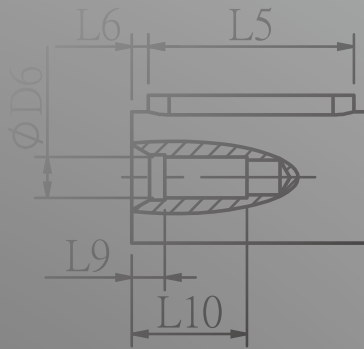

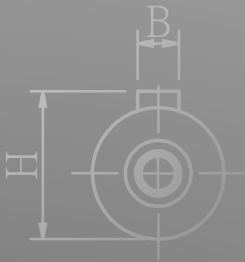

PGH60T/PGH90T/PGH115T/PGH142T/PGH180T

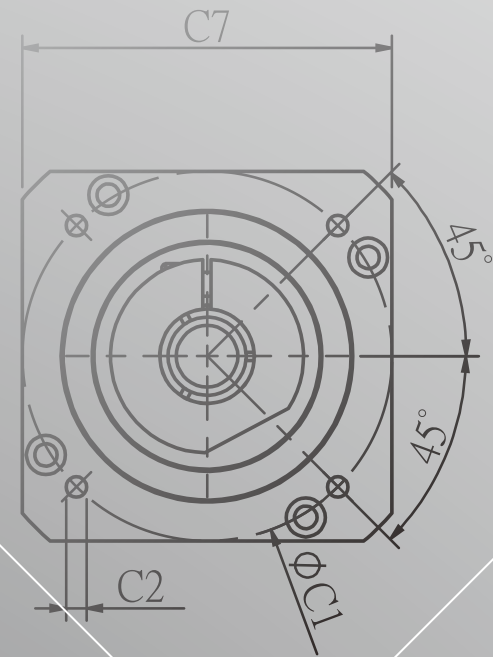
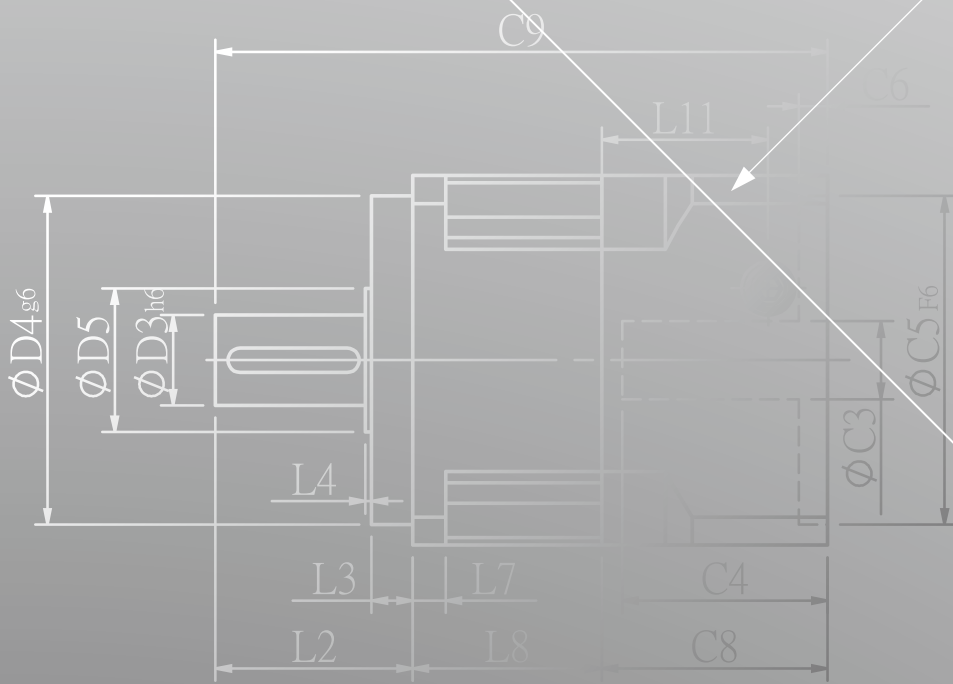
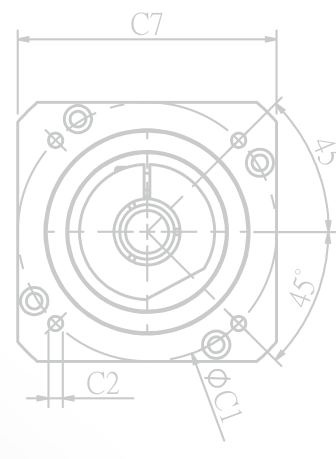
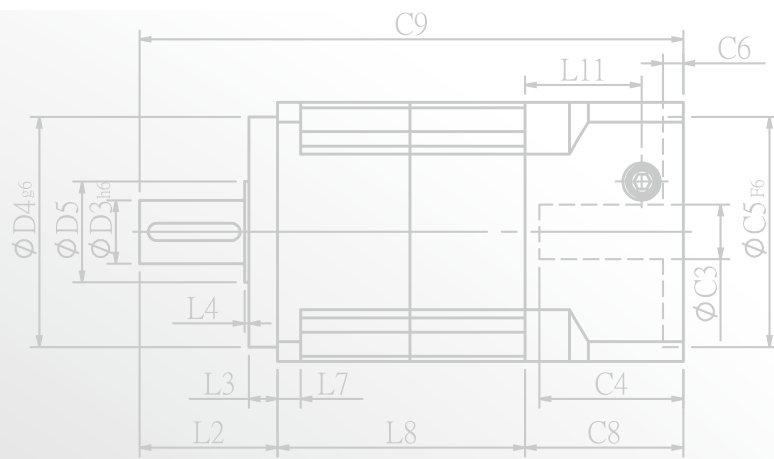
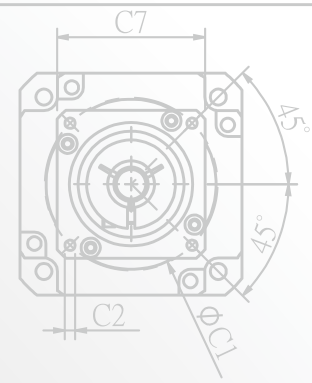
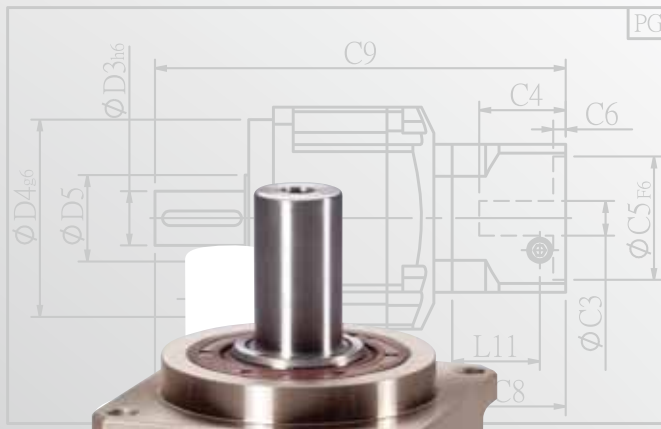

PGH Single Stage Dimensions PGH單段外型尺寸圖

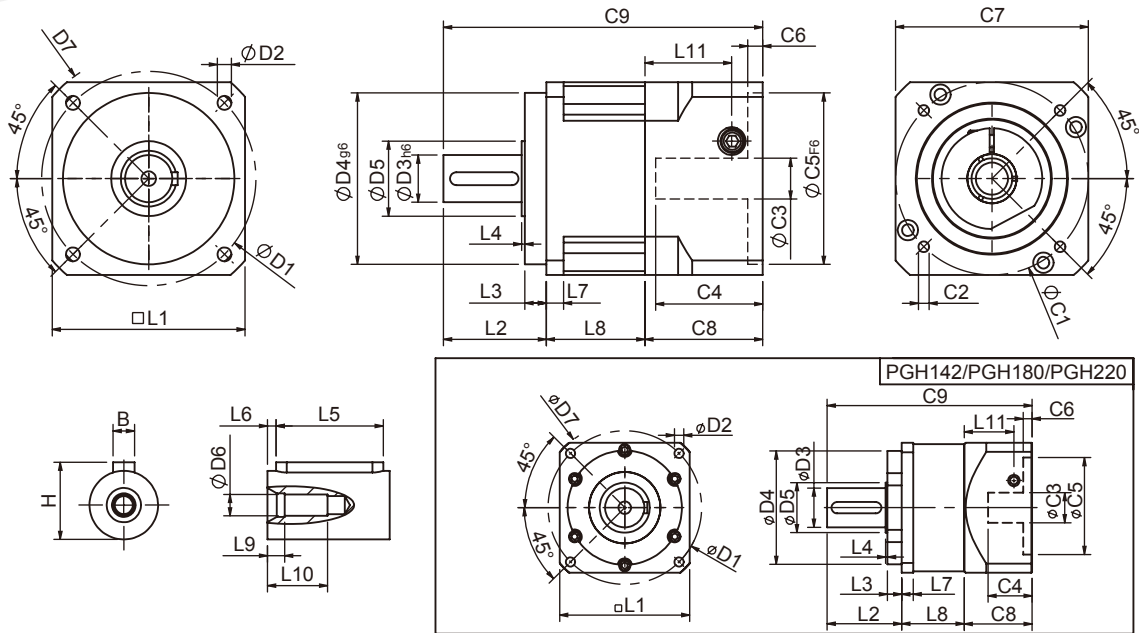

Specifications 規格

Unit:mm

尺寸 Dimensions	PGH42	PGH60	PGH90	PGH115	PGH142	PGH180	PGH220
D1	50	70	100	130	165	215	250
D2	3.4	5.5	6.5	8.5	10.5	13	17
D3 h6	13	16	22	32	40	55	75
D4 g6	35	50	80	110	130	160	180
D5	15	25	35	45	50	70	114.4
D6	M4x0.7P	M5x0.8P	M8x1.25P	M12x1.75P	M16x2.0P	M20x2.5P	M20x2.5P
D7	56	80	118	148	186	239	292
L1	42.6	60	90	115	142	182	220
L2	26	37	48	63	91.5	100.5	138
L3	5.5	7	10	10	10	16	30
L4	1	1.5	1.5	3.5	2.5	2.5	3
L5	15	25	32	40	60	70	90
L6	2	2	3	5	5	6	7
L7	4	6	8	11	16	18	20
L8	28.3	37	46	57	75.5	94	111
L9	4	4	4.5	6	6	8	15
L10	14	16.5	20.5	30	38	48	42
L11	29	35.5	40.5	42	63	69.5	96
C1 ²	46	70	90	115	145	200	235
C2 ²	M4x0.7P	M5x0.8P	M6x1.0P	M8x1.25P	M8x1.25P	M12x1.75P	M12x1.75P
C3 ²	≤8/≤11	≤14/≤19	≤19/≤24	≤24/≤32/≤38	≤35/≤38	≤50	≤55
C4 ²	27	37	47	56	66.5	82	112
C5 ² F6	30	50	70	95	110	114.3	200
C6 ²	4	4	6	10	6	13	6
C7 ²	42.6	60	90	115	140	180	220
C8 ²	38.5	46	55	63	80	95	120
C9 ²	92.8	120	149	183	247	289.5	369
B	5	5	6	10	12	16	20
H	15	18	24.5	35	43	59	79.5

★ C1~C9是公製標準馬達連接板尺寸,請依所選用的馬達決定。

★ 本公司有權針對以上數據規格進行設計變更不先行告知。

★ C1~C9 are motor specific dimensions(metric std shown), Size may vary according to the motor flange chosen.

★ Specification subject to change without notice.

PGH Double Stage Dimensions-1 PGH雙段外型尺寸圖-1

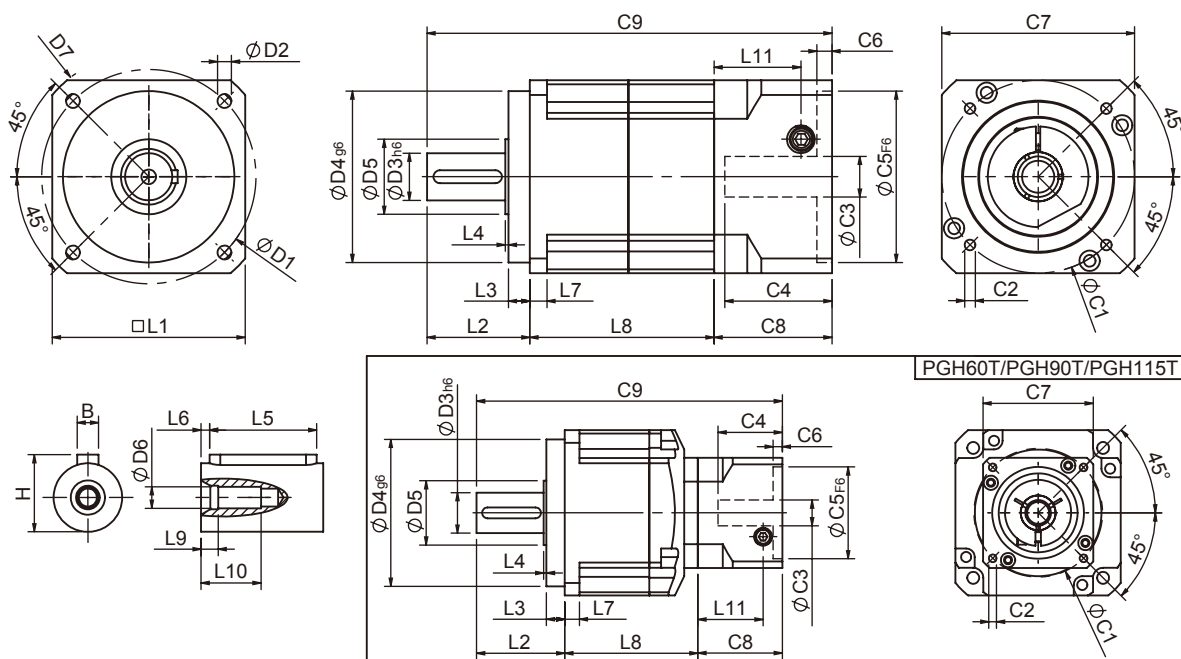

Specifications 規格

Unit:mm

尺寸 Dimensions	PGH42	PGH60	PGH60T	PGH90	PGH90T	PGH115T
D1	50		70		100	130
D2	3.4		5.5		6.5	8.5
D3h6	13		16		22	32
D4g6	35		50		80	110
D5	15		25		35	45
D6	M4x0.7P		M5x0.8P		M8x1.25P	M12x1.75P
D7	56		80		118	148
L1	42.6		60		90	115
L2	26		37		48	63
L3	5.5		7		10	10
L4	1		1.5		1.5	3.5
L5	15		25		32	40
L6	2		2		3	5
L7	4		6		8	11
L8	55.3	70	65.5	86	78.5	99.5
L9	4		4		4.5	6
L10	14		16.5		20.5	30
L11	29	35.5	29	40.5	35.5	40.5
C1 ²	46	70	46	90	70	90
C2 ²	M4x0.7P	M5x0.8P	M4x0.7P	M6x1.0P	M5x0.8P	M6x1.0P
C3 ²	≤8/≤11	≤14/≤19	≤8/≤11	≤19/≤24	≤14	≤19/≤24
C4 ²	27	37	27	47	37	47
C5 ² F6	30	50	30	70	50	70
C6 ²	4	4	4	6	4	6
C7 ²	42.6	60	42.6	90	60	90
C8 ²	38.5	46	38.5	55	46	55
C9 ²	119.8	153	141	189	172.5	217.5
B	5		5		6	10
H	15		18		24.5	35

★ C1~C9是公製標準馬達連接板尺寸,請依所選用的馬達決定。

★ 本公司有權針對以上數據規格進行設計變更不先行告知。

★ C1~C9 are motor specific dimensions(metric std shown), Size may vary according to the motor flange chosen.

★ Specification subject to change without notice.

PGH Double Stage Dimensions-2 PGH雙段外型尺寸圖-2

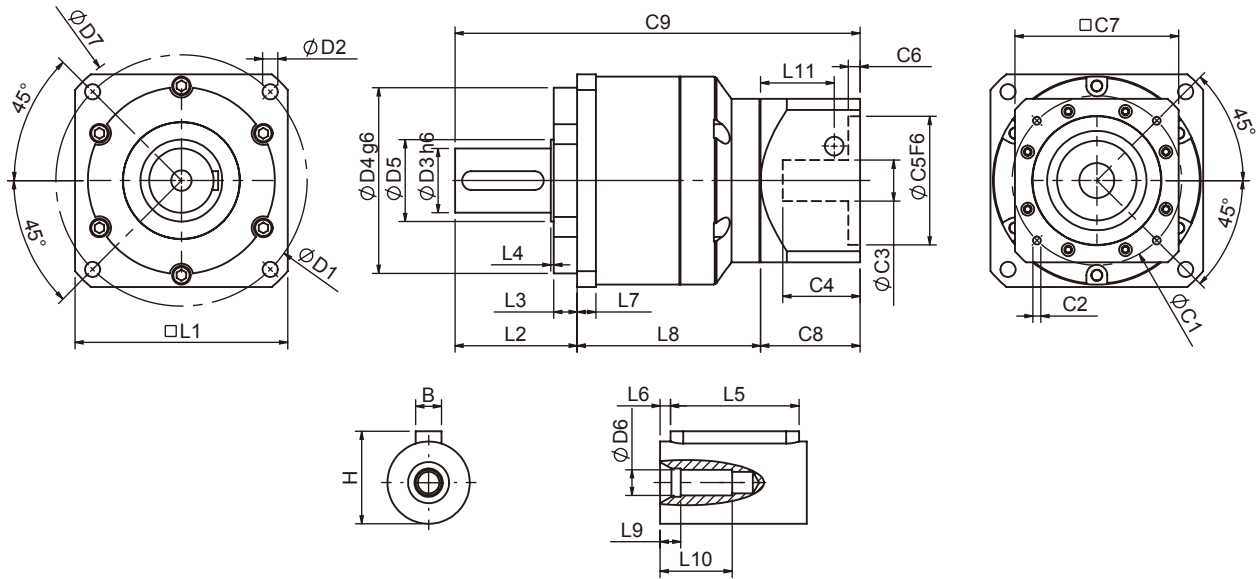

Specifications 規格

Unit:mm

尺寸 Dimensions	PGH142T	PGH180T	PGH220T
D1	165	215	250
D2	10.5	13	17
D3h6	40	55	75
D4g6	130	160	180
D5	50	70	114.4
D6	M16x2.0P	M20x2.5P	M20x1.5P
D7	186	239	292
L1	142	182	220
L2	91.5	100.5	138
L3	10	16	30
L4	2.5	2.5	3
L5	60	70	90
L6	5	6	7
L7	16	18	20
L8	127.5	166	202
L9	6	8	15
L10	38	48	42
L11	42	63	74
C1 ²	115	145	200
C2 ²	M8x1.25P	M8x1.25P	M12x1.75P
C3 ²	$\leq 24/\leq 32/\leq 38$	$\leq 35/\leq 38$	≤ 50
C4 ²	56	66.5	81
C5 ² F6	95	110	114.3
C6 ²	10	6	6
C7 ²	115	140	180
C8 ²	63	80	93
C9 ²	282	346.5	433
B	12	16	20
H	43	59	79.5

★ C1~C9是公製標準馬達連接板尺寸,請依所選用的馬達決定。

★ 本公司有權針對以上數據規格進行設計變更不先行告知。

★ C1~C9 are motor specific dimensions(metric std shown), Size may vary according to the motor flange chosen.

★ Specification subject to change without notice.

PGH Specifications Table PGH性能規格共表

規格 Specifications		節數 Stage	減速比 Ratio	PGH-42	PGH-60	PGH-90	PGH-115	PGH-142	PGH-180	PGH-220	
額定輸出力矩 T_{2N} Nominal Output Torque	N • m	1	3	19	53	145	290	520	950	1100	
			4	20	55	150	300	550	1050	1700	
			5	22	60	160	330	600	1200	2000	
			6	20	55	150	310	560	1100	1900	
			7	19	50	140	300	530	1100	1800	
			8	17	45	120	260	480	1000	1600	
			9	14	40	100	230	450	900	1500	
			10	14	40	100	230	450	900	1500	
			2	15	19	53	145	290	520	950	2000
				20	20	55	150	300	550	1050	2000
		25		22	60	160	330	600	1200	2000	
		30		22	60	160	330	600	1200	2000	
		35		22	60	160	330	600	1200	2000	
		40		22	60	160	330	600	1200	2000	
		45		22	60	160	330	600	1200	2000	
		50		22	60	160	330	600	1200	2000	
		60		20	55	150	310	560	1100	1900	
		70		19	50	140	300	530	1100	1800	
		80	17	45	120	260	480	1000	1600		
		90	14	40	100	230	450	900	1500		
100	14	40	100	230	450	900	1500				
急停力矩 T_{2NOT} Emergency Stop Torque	N • m	3.0 倍額定輸出力矩 (3.0 times of Nominal Output Torque) (* 最大輸出力矩 Max. Output Torque T_{2B} = 60% of Emergency Stop Torque)									
額定輸入轉速 n_{1N} Nominal Input Speed	rpm	1,2	3-100	5000	5000	4000	4000	3000	3000	2000	
最大輸入轉速 n_{1max} Max. Input Speed	rpm	1,2	3-100	10000	10000	8000	8000	6000	6000	4000	
超精密背隙 Micro Backlash P0	arcmin	1	3-10	≤ 2	≤ 2	≤ 2	≤ 1	≤ 1	≤ 1	≤ 1	
精密背隙 Precision Backlash P1	arcmin	1	3-10	≤ 4	≤ 4	≤ 4	≤ 3	≤ 3	≤ 3	≤ 3	
		2	15-100	≤ 6	≤ 6	≤ 6	≤ 5	≤ 5	≤ 5	≤ 5	
標準背隙 Standard Backlash P2	arcmin	1	3-10	≤ 6	≤ 6	≤ 6	≤ 5	≤ 5	≤ 5	≤ 5	
		2	15-100	≤ 8	≤ 8	≤ 8	≤ 7	≤ 7	≤ 7	≤ 7	
扭轉剛性 Torsional Rigidity	N • m / arcmin	1,2	3-100	3	7	14	25	50	145	225	
容許徑向力 F_{2rB}^1 Max. Radial Load	N	1,2	3-100	760	1570	3250	6620	9400	14500	33000	
容許軸向力 F_{2aB}^1 Max. Axial Load	N	1,2	3-100	410	750	1870	3310	4670	6460	18530	
使用溫度 Operating Temp.	°C	-10 °C ~ +90 °C									
使用壽命 Service Life	hr	3-100 20,000 (10,000/ 連續運轉 Continuous operation)									
效率 Efficiency	%	1	3-10	≥ 97%							
		2	15-100	≥ 94%							
重量 Weight	kg	1	3-10	0.6	1.3	3.5	7.8	16.1	27	55	
		2	15-100	0.9	2.0/1.6	5.6/3.9	9.5	19	34	68.5	
安裝方向 Mounting Position	-	1,2	3-100	任意方向 Any direction							
噪音值 Noise Level ²	dBA/1m	1,2	3-100	56	58	60	63	65	67	70	
防護等級 Protection Class	-	1,2	3-100	IP65							
潤滑 Lubrication	-	1,2	3-100	全合成潤滑油 Synthetic Lubricant							
減速機轉動慣量 Inertia(J1)											
節數 Stage	減速比 Ratio	單位 unit	PGH-42	PGH-60	PGH-90	PGH-115	PGH-142	PGH-180	PGH-220		
1	3	Kg • cm ²	0.03	0.23	0.97	2.35	10.00	30.50	79.50		
	4		0.02	0.18	0.67	1.66	7.17	25.86	58.21		
	5		0.02	0.17	0.65	1.50	6.52	23.63	54.36		
	6/7/8		0.02	0.14	0.60	1.45	6.17	22.92	54.12		
	9/10		0.02	0.14	0.58	1.41	6.10	22.73	53.98		
2	15/20/25		PGH-42	PGH-60(T)	PGH-90(T)	PGH-115T	PGH-142T	PGH-180T	PGH-220T		
	30/35/40		0.02	0.17(0.02)	0.65(0.17)	0.65	1.50	6.52	23.63		
			0.02	0.14(0.02)	0.60(0.14)	0.60	1.45	6.17	22.92		
			0.02	0.14(0.02)	0.58(0.14)	0.58	1.41	6.10	22.73		
			45/50/60/70/80/90/100	0.02	0.14(0.02)	0.58(0.14)	0.58	1.41	6.10	22.73	

* 1. 輸出轉速 100rpm 時，作用於輸出軸中心位置。Applied to the output shaft center @100rpm.

* 2. 3000rpm 空載量測。Measured at 3000 rpm with no load. These values are measured by gearbox with ratio = 10 (1-stage) or ratio = 100 (2-stage) at nominal input speed or 3000 rpm (if nominal input speed is higher than 3000 rpm) with no load.

※本公司有權對以上數據規格逕行設計變更不先行告知。The above figures/specifications are subject to change without prior notice.

Products due to human error, natural disasters or other factors lead to poor or damaged, will not be covered under warranty.

產品因人為原因或天災等因素導致不良或損壞，不在保固範圍內。