

EMTW

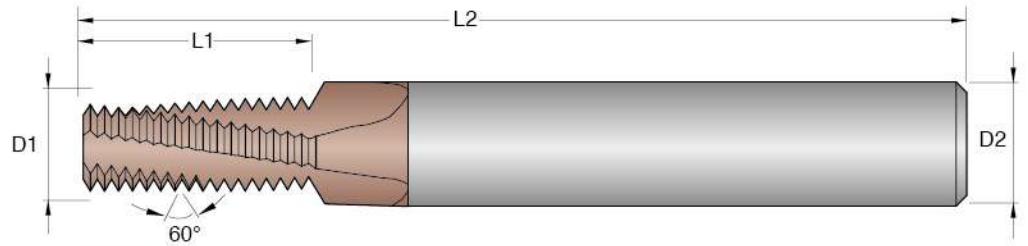

螺紋銑刀

► Internal Threading / Helical Flutes / for **H P K M S N** unit: mm

型號 Order No.	螺紋規格 Thread Size	直徑 Diameter D1	刃長 Flute Length L1	全長 O.A.L. L2	柄徑 Shank Dia D2	刃數 Flute
EMTW 03P050	M3x0.5	2.2	5.3	50	6	3
EMTW 04P070	M4x0.7	3.1	7.4	50	6	3
EMTW 05P080	M5x0.8	3.6	9.2	50	6	3
EMTW 06P100	M6x1.0	4.0	10.5	50	6	3
EMTW 08P125	M8x1.25	5.0	14.4	50	6	3
EMTW 10P150	M10x1.5	7.0	17.3	60	8	3
EMTW 12P175	M12x1.75	8.0	20.1	60	8	3
EMTW 16P200	M16x2.0	10.0	27.0	75	10	3
EMTW 20P250	M20x2.5	14.0	33.8	100	14	4

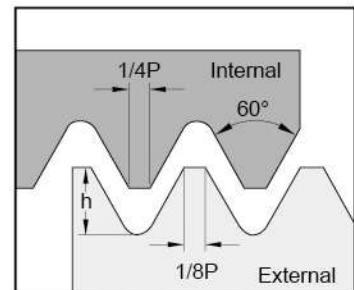
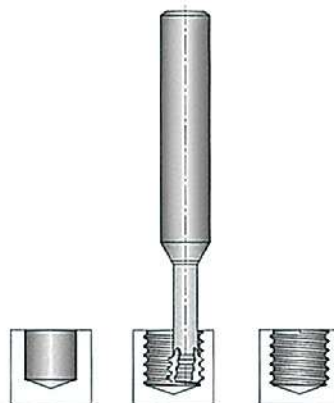

Defined by: R262 (DIN 13)
Tolerance class: 6g/6H