

APM 直角端銑刀 SHOULDER / CUTTING END MILLS (APM)

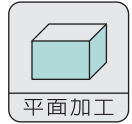

$\varnothing 32$
 $\varnothing 40$
 $\varnothing 50$
 $\varnothing 63$
 $\varnothing 80$

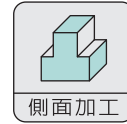
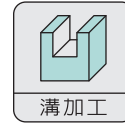
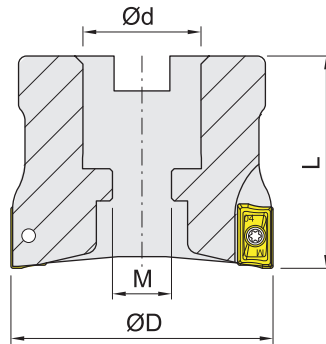

Metric

Item code		Dimensions,mm				Teeth	Insert	Spare parts	Weight Kg
無水孔Non-coolant	水孔Coolant	D	d	L	M				
NEW APM03205-16.0		32	16.0	40	9	5	AOMT1236..	①	0.16
NEW APM04006-16.0		40	16.0	40	9	6			0.23
APM05004-22.0		50	22.0	40	11	4			0.41
APM05007-22.0		50	22.0	40	11	7			0.38
APMB04004-16.0		40	16.0	40	9	4	AOMT1848..	②	0.23
APMB05005-22.0		50	22.0	40	11	5			0.34
APMB06306-22.0		63	22.0	40	11	6	AOMT1848..	③	0.55

Inch

Item code		Dimensions,mm				Teeth	Insert	Spare parts	Weight Kg
無水孔Non-coolant	水孔Coolant	D	d	L	M				
APM05007-25.4		50	25.4	50	13	7	AOMT1236..	①	0.47
APM06308-25.4		63	25.4	50	13	8			0.73
APM08009-25.4		80	25.4	50	13	9			1.14
APMB08007-25.4		80	25.4	50	13	7	AOMT1848..	③	1.29

被切削材 Workpiece material	Steel 鋼	P	●	●		
	Stainless steel 不銹鋼	M	● <td>● <td></td> <td></td> </td>	● <td></td> <td></td>		
	Cast iron 鑄鐵	K	● <td></td> <td>●</td> <td></td>		●	
	Non-ferrous metal 非鐵金屬	N				●

Insert Shape	Description	GRADE 材質				Dimensions,mm			
		Coated 塗層			Cemented Carbide 硬質合金	A	B	S	Re
		NW948	NW950	NV313					
	AOGT123604PEFR-GM				●	12	6.6	3.6	0.4
	AOMT123604PEER-M	●				12	6.6	3.6	0.4
	AOMT123608PEER-M	●	●			12	6.6	3.6	0.8
	AOMT184808PEER-M		●			18	9	4.8	0.8
	AOMT123608PEER-H			●		12	6.6	3.6	0.8
	AOMT184804PEER-H				●	18	9	4.8	0.4

內徑車刀
BORING BARS

外徑車刀
TOOLHOLDERS

牙刀 & 開槽刀
THREADING & GROOVING

銑刀
MILLING

孔加工
BORING TOOLS COMPONENTS

配件
SPARE PARTS