

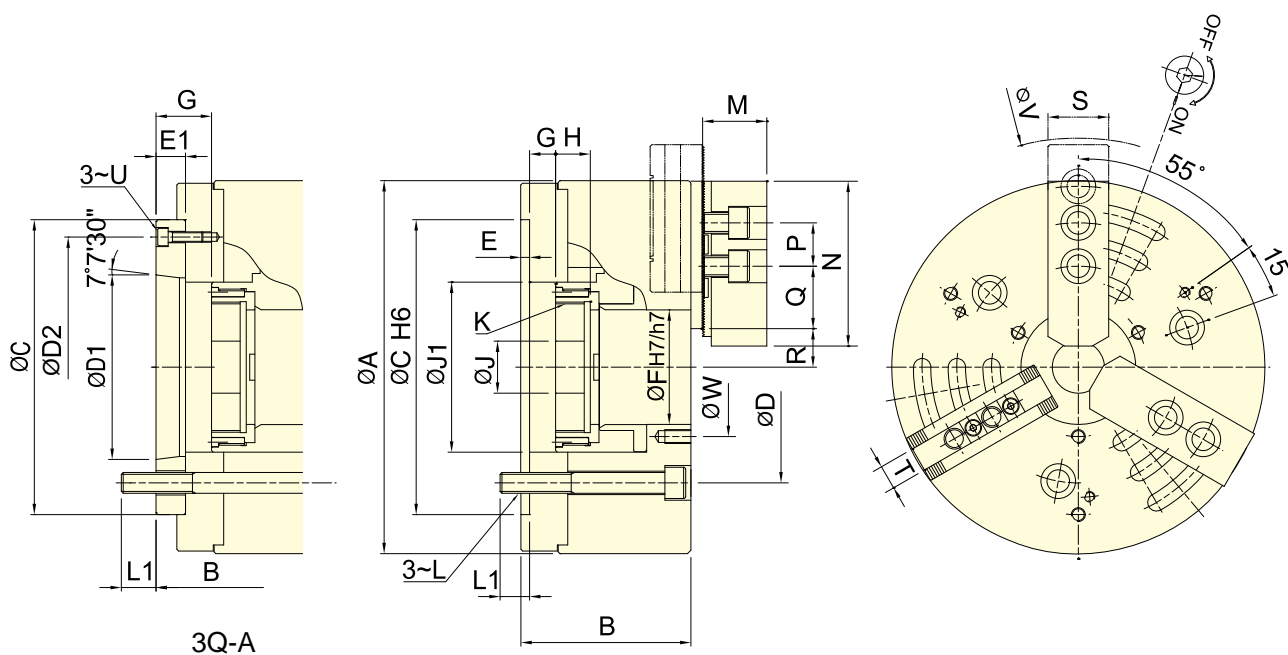

- The shortest changes time for soft jaw, it is the high repeatability precision.
- Chuck of all parts hardened, ground and lubricated directly.
- High rigidity and high clamping accuracy.
- For safety system that master jaw will complete return when base jaw and serration match up properly.



Subject to technical changes

## SPECIFICATIONS

Model		Plunger stroke	Jaw stroke (Dia.)	Chucking Dia. Max.	Chucking Dia. Min.	Max. D.B. pull	Max. Clamping force	Max. speed	Moment of inertia	Weight	Matching cyl.	Max. pressure	
		mm	mm	mm	mm	kN (kgf)	kN (kgf)	min <sup>-1</sup> (r.p.m.)	kg · m <sup>2</sup>	kg		MPa (kgf/cm <sup>2</sup> )	
<b>3Q-08</b>	<b>A6</b>	16	7.5	210	23	45.0(4590)	82.0(8360)	5000	0.15	24.5	<b>26.0</b>	TK-A1068	3.1(31)
<b>3Q-10</b>	<b>A8</b>	19	8.8	254	41	60.0(6118)	115.0(11270)	4500	0.41	44.0	<b>46.0</b>	TK-A1287	2.8(28)
<b>3Q-12</b>	<b>A8</b>	23	10.6	315	47	81.0(8259)	165.0(16825)	3500	0.96	73.0	<b>75.0</b>	TK-A1511	2.4(25)

## DIMENSIONS

Model	A	B	C	D	D1	D2	E	E1	F	G max.	G min.	H	J				
<b>3Q-08</b>	<b>A6</b>	215	98	<b>110</b>	170	133.4	<b>106.38</b>	<b>150</b>	5	<b>17</b>	66	14.5	<b>32</b>	-1.5	<b>15.5</b>	20	30
<b>3Q-10</b>	<b>A8</b>	254	119	<b>132</b>	220	171.4	<b>139.72</b>	<b>190</b>	5	<b>18</b>	81	8.5	<b>26.5</b>	-10.5	<b>7.5</b>	39	45
<b>3Q-12</b>	<b>A8</b>	315	133	<b>145</b>	220	171.4	<b>139.72</b>	<b>190</b>	6	<b>18</b>	106	8.5	<b>26.5</b>	-14.5	<b>3.5</b>	42	50

Model	J1	K max.	L	L1	M	N	P	Q	R max.	R min.	S	T	U	V	W		
<b>3Q-08</b>	<b>A6</b>	98	M75x2	M12	17	<b>20</b>	37	95	25	36	20.8~44.8	17.1~41.1	35	14	<b>M6</b>	264	80
<b>3Q-10</b>	<b>A8</b>	115	M90x2	M16	23	<b>25</b>	42	110	30	40.5	21.1~52.8	16.7~48.2	40	16	<b>M8</b>	312	100
<b>3Q-12</b>	<b>A8</b>	140	M115x2	M16	22	<b>24</b>	50	110	30	57	34.1~70.1	28.8~64.8	50	21	<b>M8</b>	360	130

1. The dimensions and the specifications of 3Q-A type are in red data.



- The surface of the center through cover is grinding treated, it can be the position base surface of the jig/workpiece.
- The slideway of main jaws is inclined. It improves the clamping force and reduces the upfloat situation of the workpiece.
- Work with standard top jaws.
- Airtight pressure detect function is optional.
- External gripping only.

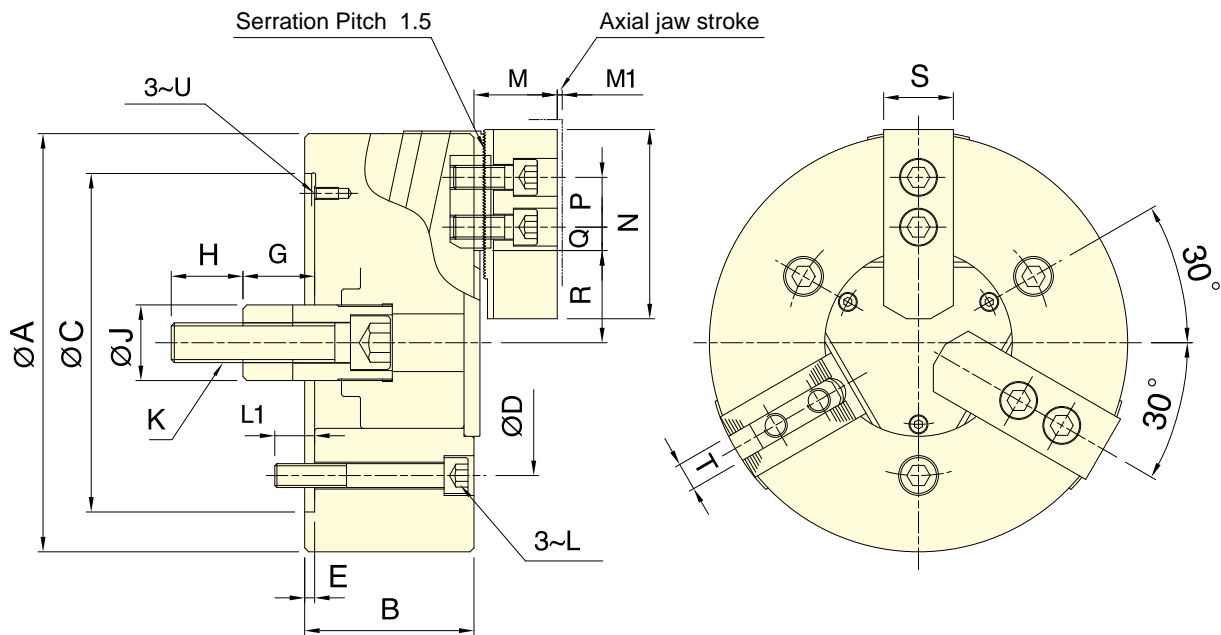

Subject to technical changes

## SPECIFICATIONS

Model	Plunger stroke	Jaw stroke (Dia.)	Chucking Dia.Max.	Chucking Dia.Min.	Max. D.B. pull	Max. Clamping force	Max. speed	Moment of inertia	Weight	Matching cyl.	Max. pressure
	mm	mm	mm	mm	kN (kgf)	kN (kgf)	min <sup>-1</sup> (r.p.m.)	kg · m <sup>2</sup>	kg		MPa (kgf/cm <sup>2</sup> )
<b>3N-06</b>	20	8.1 (axial 0.9)	165	14	18 (1835)	61.5 (6270)	5000	0.05	11.1	RK-100(N)	2.6 (26)
<b>3N-08</b>	23	9.4 (axial 1.0)	210	17	25 (2540)	85.8 (8750)	4500	0.14	24.5	RK-125(N)	2.2 (22)
<b>3N-10</b>	25	10.2 (axial 1.1)	254	22	29 (2950)	108 (11000)	4000	0.32	34.5	RK-150(N)	1.8 (18)

## DIMENSIONS

Model	A	B	C(H6)	D	E	G max.	G min.	H	J	K	L
<b>3N-06</b>	165	72	140	104.8	5	54.5	34.5	36	34	M16x2	M10
<b>3N-08</b>	210	85	170	133.4	5	59	36	36	38	M20x2.5	M12
<b>3N-10</b>	254	89	220	171.4	5	63	38	36	45	M20x2.5	M16

  

Model	L1	M	M1	N	P	Q max.	Q min.	R max.	R min.	S	T	U
<b>3N-06</b>	16	41	0.9	73	20	15.25	7.75	38.3	34.25	31	12	M6
<b>3N-08</b>	20	42	1.0	95	25	22.25	11.75	46.3	41.6	35	14	M6
<b>3N-10</b>	24	47	1.1	110	30	33.75	11.25	52.1	47	40	16	M8



- CRANK type with two pairs of 2 jaws self center independent of each other.
- The 4T series is suitable for square bar and other nonuniform shaped workpieces.
- Patent numbers :  
PAT.NO.M359385 (Taiwan)  
PAT.NO.ZL200920009309.1(China)

SPECIAL PURPOSE POWER CHUCKS

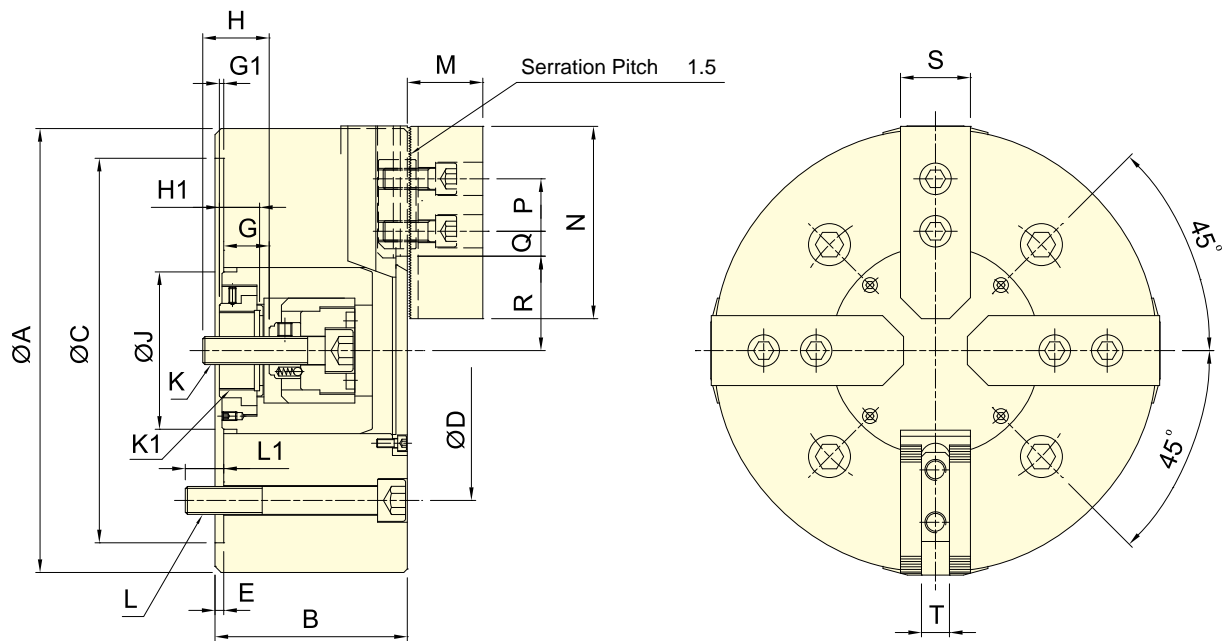

Subject to technical changes

### SPECIFICATIONS

Model	Plunger stroke	Jaw stroke (Dia.)	Chucking Dia. Max.	Chucking Dia. Min.	Max. D.B. pull	Max. Clamping force	Max. speed	Moment of inertia	Weight	Matching cyl.	Max. pressure
	mm	mm	mm	mm	kN (kgf)	kN (kgf)	min <sup>-1</sup> (r.p.m.)	kg · m <sup>2</sup>	kg		MPa (kgf/cm <sup>2</sup> )
4T-08	17	13.6	210	24	16.0(1630)	54.3(5540)	3000	0.15	23.2	RD-120(N)	1.7(17)
4T-10	20	16	254	50	21.6(2200)	79.4(8100)	2100	0.35	44.3	RD-125(N)	2.2(22)
4T-12	20	16	304	50	21.6(2200)	79.4(8100)	1500	0.66	57.6	RD-125(N)	2.2(22)
4T-15	25	19.6	381	60	27.2(2780)	105.3(10750)	1200	2.25	118.3	RD-125(N)	2.7(27)

### DIMENSIONS

Model	A	B	C(H6)	D	E	G max.	G min.	G1 max.	G1 min.	H	H1	J	K
4T-08	210	91	170	133.4	5	32	15	2.5	-14.5	29	20	61	M14x2
4T-10	254	110	220	171.4	5	36.5	16.5	10	-10	36	23	90	M16x2
4T-12	304	110	220	171.4	5	36.5	16.5	10	-10	36	23	90	M16x2
4T-15	381	135	300	235	6	44.5	19.5	5	-20	45	28	125	M20x2.5

Model	K1	L	L1	M	N	P	Q max.	Q min.	R max.	R min.	S	T
4T-08	M34x1.5	4~M2	20	38	95	25	25.25	13.25	46.1	39.3	35	14
4T-10	M45x1.5	4~M16	25	43	110	30	32.25	12.75	59	51	40	16
4T-12	M45x1.5	4~M16	25	43	110	30	54.75	15.75	59	51	40	16
4T-15	M55x2	4~M20	30	51	130	30	66.5	12.5	78.9	69.1	50	21



- Radial clamp and axial pull down at the same time, keep the workpiece attaching close to the base surface of the chuck.
- Almost no workpiece uplifting displacement.
- The body and the cylinder pull-down mechanism are heat-treated and fine boring, which guarantee the clamping precision and durability.
- Airtight pressure detect function is optional.

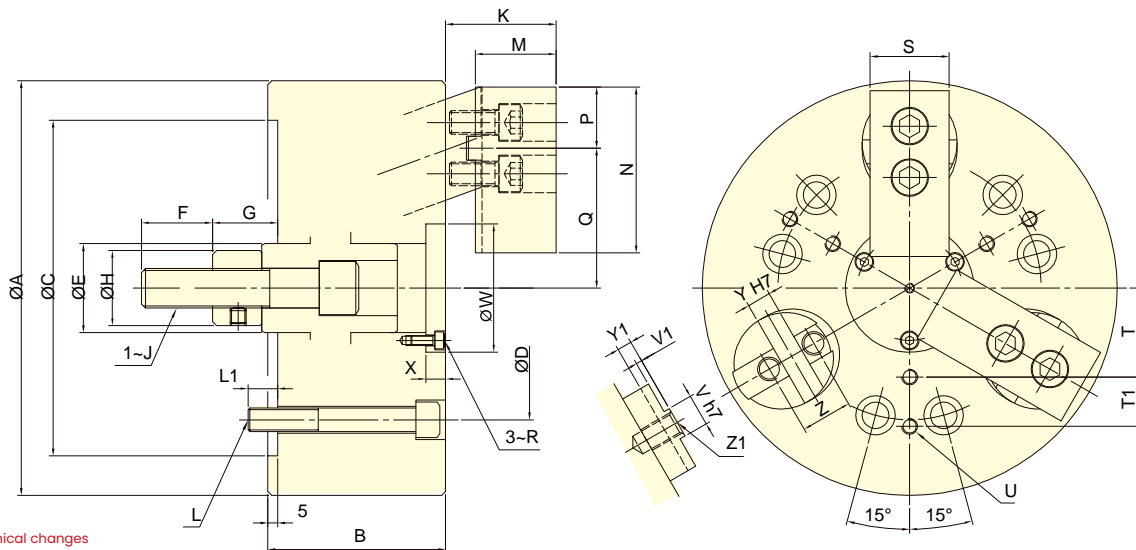

Subject to technical changes

## SPECIFICATIONS

Model	Plunger stroke	Jaw stroke (Dia.)	Chucking Dia. Max.	Chucking Dia. Min.	Max. D.B. pull	Max. Clamping force	Max. speed	Moment of inertia	Weight	Matching cyl.	Max. pressure
	mm	mm	mm	mm	kN (kgf)	kN (kgf)	min <sup>-1</sup> (r.p.m.)	kg · m <sup>2</sup>	kg		MPa (kgf/cm <sup>2</sup> )
3D-04	7	5	110	13	6.0(612)	10.5(1070)	3500	0.007	4.5	RK-75	1.6(16.5)
3D-05	7	5	135	21	10.0(1020)	17.0(1730)	3500	0.018	7.9	RK-75	2.7(27.5)
3D-06	10	7.2	165	22	15.0(1530)	25.0(2550)	3500	0.051	15	RK-100	2.1(21.4)
3D-08	10	7.2	210	28	25.0(2550)	45.0(4590)	3000	0.15	26	RK-125	2.2(22.5)
3D-10	15	10.8	254	35	35.0(3569)	60.0(6118)	2500	0.37	46	RK-125	3.1(31.6)
3D-12	15	10.8	304	50	45.0(4590)	75.0(7650)	2000	0.79	70	RK-150	2.8(28.5)
3D-15	20	14.5	381	60	53.9(5500)	90.0(9180)	1500	2.25	132	RK-150	3.4(34.2)

## DIMENSIONS

Model	A	B	C	D	E	F	G max.	G min.	H	J	K max.	K min.	L	L1	M	N	P
3D-04	110	60	85	70.6	25	20	22	15	25	M10	30	23	3-M10	15	19.5	50	22
3D-05	135	70	110	82.6	30	25	24	17	28	M12	35	28	3-M10	16	24.5	56	23
3D-06	165	85	140	104.8	35	36	37	27	32	M16	45	35	6-M10	16	31	70	27
3D-08	210	90	170	133.4	45	36	38	28	38	M20	56	46	6-M12	15	41	84	31
3D-10	254	110	220	171.4	55	46	47	32	50	M24	65	50	6-M16	24	46	100	38
3D-12	304	125	220	171.4	55	50	49.5	34.5	53	M27	70	55	6-M16	22	51	120	42
3D-15	381	140	300	235	70	55	61	41	55	M30	86	66	6-M20	30	60	165	60

Model	Q max.	Q min.	R	S	T	T1	U	v (h7)	v1	w	x	Y(H7)	Y1	Z	Z1
3D-04	37	34.5	M3	25	22.5	-	3-M6	8	2.5	35	2	8	6	-	M10
3D-05	46	43.5	M3	30	27.5	-	3-M6	8	2.5	44	2	8	6	-	M12
3D-06	57.7	54.3	M4	35	35	20	6-M6	10	2.5	52	7	10	6.5	-	M14
3D-08	70.8	67.2	M5	40	45	25	6-M8	16	3	65	10	12	7.5	26	M12
3D-10	85	79.6	M6	50	55	30	6-M8	18	3	75	12	15	7.5	32	M14
3D-12	101.9	96.5	M6	60	70	35	6-M10	20	3	90	12	17	7.5	36	M16
3D-15	135.6	128.3	M8	70	95	45	6-M12	24	4	120	13	20	6	40	M16



- Radial clamp and axial pull down at the same time, keep the workpiece attaching close to the base surface of the chuck.
- Almost no workpiece uplifting displacement.
- The body and the cylinder pull-down mechanism are heat-treated and fine boring, which guarantee the clamping precision and durability.
- Airtight pressure detect function is optional.

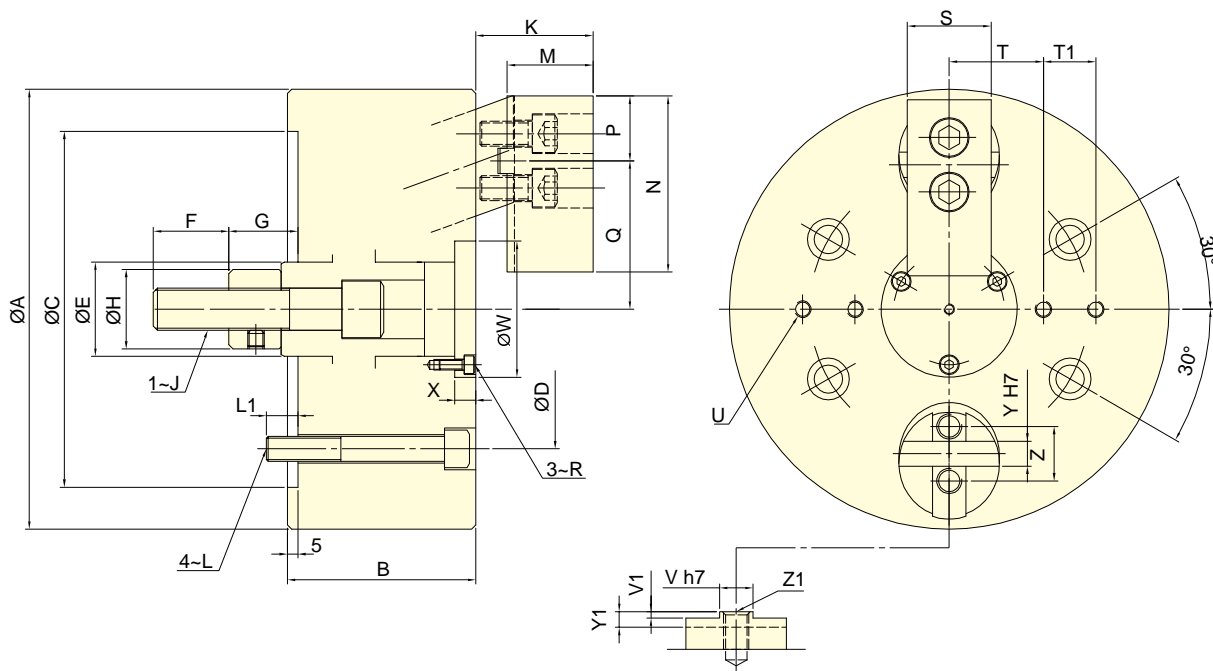

Subject to technical changes

## SPECIFICATIONS

Model	Plunger stroke	Jaw stroke (Dia.)	Chucking Dia.Max.	Chucking Dia.Min.	Max. DB. pull	Max. Clamping force	Max. speed	Moment of inertia	Weight	Matching cyl.	Max. pressure
	mm	mm	mm	mm	kN (kgf)	kN (kgf)	min <sup>-1</sup> (r.p.m.)	kg · m <sup>2</sup>	kg		MPa (kgf/cm <sup>2</sup> )
<b>2D-06</b>	10	7.2	165	22	10.0(1020)	16.7(1700)	3500	0.045	12	RK-100	1.4(14.3)
<b>2D-08</b>	10	7.2	210	28	16.7(1700)	30.0(3060)	3500	0.13	23	RK-125	1.5(15)
<b>2D-10</b>	15	10.8	254	35	23.3(2379)	40.0(4079)	2500	0.34	43	RK-125	2.1(21.1)

## DIMENSIONS

Model	A	B	C	D	E	F	G max.	G min.	H	J	K max.	K min.	L	L1	M	N	P
<b>2D-06</b>	165	85	140	104.8	35	36	37	27	32	M16	45	35	M10	16	31	70	27
<b>2D-08</b>	210	90	170	133.4	45	36	38	28	38	M20	56	46	M12	15	41	84	31
<b>2D-10</b>	254	110	220	171.4	55	46	47	32	50	M24	65	50	M16	24	46	100	38

Model	Q max.	Q min.	R	S	T	T1	U	v (h7)	V1	W	X	Y (H7)	Y1	Z	Z1
<b>2D-06</b>	57.7	54.3	M4	35	35	20	4-M6	10	2.5	52	7	10	6.5	-	M14
<b>2D-08</b>	70.8	67.2	M5	40	45	25	4-M8	16	3	65	10	12	7.5	26	M12
<b>2D-10</b>	85	79.6	M6	50	55	30	4-M8	18	3	75	12	15	7.5	32	M14



- Pin-Arbor Draw Down type 3-jaw thru-hole power chuck.
- High radial gripping force and high accuracy.
- Suitable for heavy machining.

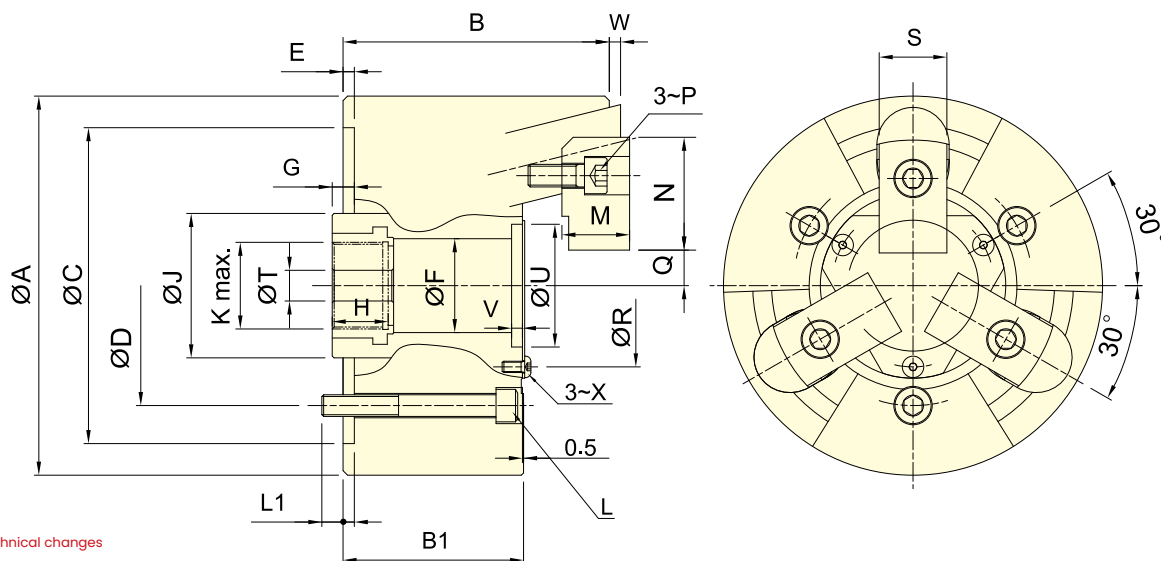

Subject to technical changes

## SPECIFICATIONS

Model	Plunger stroke	Jaw stroke (Dia.)	Chucking Dia.Max.	Chucking Dia.Min.	Max. D.B. pull	Max. Clamping force	Max. speed	Moment of inertia	Weight	Matching cyl.	Max. pressure
	mm	mm	mm	mm	kN (kgf)	kN (kgf)	min <sup>-1</sup> (r.p.m.)	kg · m <sup>2</sup>	kg		MPa (kgf/cm <sup>2</sup> )
<b>3U-203</b>	4	2	42	14	5.8(590)	16.7(1700)	10000	0.001	1.8	RK-75(N)	1.6(16)
<b>3U-204</b>	6	3	60	10	10.0(1020)	28.4(2900)	8000	0.005	3.9	RK-75(N)	2.7(27)
<b>3U-205</b>	6	3	84	15	13.9(1420)	39.7(4050)	8000	0.012	6.8	RK-100(N)	2.0(20)
<b>3U-206</b>	10	5	105	24	17.9(1830)	57.8(5900)	7000	0.055	14.7	RK-100(N)	2.6(26)
<b>3U-208</b>	12	6	132	25	25.0(2550)	80.0(8150)	6000	0.14	25.5	RK-125(N)	2.2(22)
<b>3U-210</b>	10	5	163	34	31.0(3160)	100.0(10100)	4500	0.36	43.5	RK-125(N)	3.1(31)
<b>3U-212</b>	10	5	210	81	35.0(3570)	100.0(10100)	3600	0.68	63.0	RK-125(N)	3.1(31)

## DIMENSIONS

Model	A	B	B1	C(H6)	D	E	F	G max.	G min.	H	J	K	L	L1
<b>3U-203</b>	85	54.5	42	70	54	3.5	25	18	14	22	38	M20x1.5	3~M8	11
<b>3U-204</b>	110	72.5	55	85	70.6	4	30	16	10	24.5	42	M24x1.5	3~M10	12
<b>3U-205</b>	135	84.5	63	110	82.6	4	35	16	10	26	50	M28x1.5	3~M10	15
<b>3U-206</b>	168	118	80	140	104.8	5	45	20	10	31	60	M38x1.5	3~M10	16.5
<b>3U-208</b>	210	137	92	170	133.4	5	52	23	11	31	80	M48x2	3~M12	18
<b>3U-210</b>	254	152	102	220	171.4	5	75	25	15	37	105	M68x2	3~M16	23
<b>3U-212</b>	304	157	102	220	171.4	5	100	25	15	37	135	M92x2	3~M16	26

Model	M	N	P	Q max.	Q min.	R	S	T	U(H6)	V	W max.	W min.	X
<b>3U-203</b>	12	26	M5	7.5	6.5	38	15	10	32	3.5	2	-2	M3
<b>3U-204</b>	17	40	M6	10.75	9.25	46	20	10	38	4	3	-3	M4
<b>3U-205</b>	20	41.5	M8	13.25	11.75	55	24	10	45	5	3	-3	M5
<b>3U-206</b>	30	50	M10	15.75	13.25	72	30	17	58	6	5	-5	M5
<b>3U-208</b>	34	63	M12	16.25	13.25	82	35	17	68	6	5	-7	M6
<b>3U-210</b>	39	74	M14	20.75	18.25	107	40	17	93	6	5	-5	M8
<b>3U-212</b>	44	74	M14	44.25	41.75	130	40	17	114	6	5	-5	M10



- Pin-Arbor Draw Down type 3-jaw non-thru-hole power chuck.
- High radial gripping force and high accuracy.
- Suitable for heavy machining.
- Can work with the airtight detection device to perform axial position confirm, suitable for the precision of large length size process.

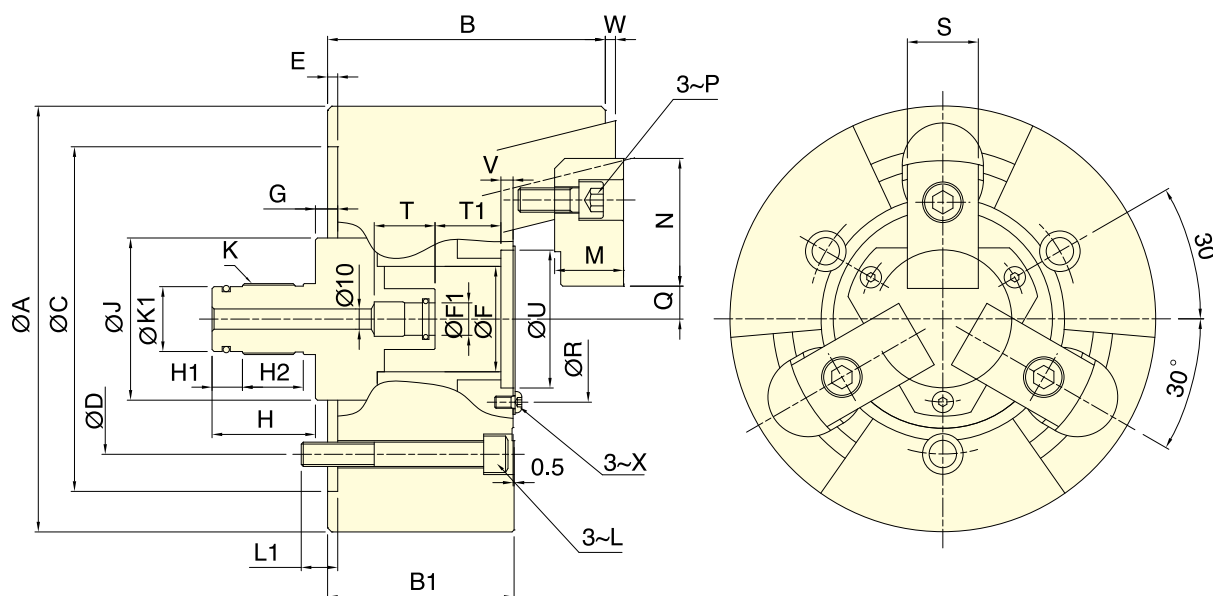

Subject to technical changes

### SPECIFICATIONS

Model	Plunger stroke	Jaw stroke (Dia.)	Chucking Dia. Max.	Chucking Dia. Min.	Max. D.B. pull	Max. Clamping force	Max. speed	Moment of inertia	Weight	Matching cyl.	Max. pressure
	mm	mm	mm	mm	kN (kgf)	kN (kgf)	min <sup>-1</sup> (r.p.m.)	kg · m <sup>2</sup>	kg		MPa (kgf/cm <sup>2</sup> )
3U-205K	6	3	84	15	13.9(1420)	39.7(4050)	8000	0.018	6.8	RL-100, RL-A100N	2.0(20)
3U-206K	10	5	105	24	17.9(1830)	57.8(5900)	7000	0.055	14.9	RL-100, RL-A100N	2.5(25)
3U-208K	12	6	132	25	25.0(2550)	80.0(8150)	6000	0.14	25.8	RL-125, RL-A125N	2.2(22)
3U-210K	10	5	163	34	31.0(3160)	100(10100)	4500	0.36	44.0	RL-125, RL-A125N	3.1(31)
3U-212K	10	5	210	81	35.0(3570)	100(10100)	3600	0.68	63.8	RL-125, RL-A125N	3.1(31)

### DIMENSIONS

Model	A	B	Bl	C(H6)	D	E	F	Fl(H8)	G max.	G min.	H	Hl	H2	J	K	K1	L
3U-205K	135	84.5	63	110	82.6	4	35	14	16	10	42	12	-	50	M25x1.5	22	M10
3U-206K	168	118	80	140	104.8	5	45	14	20	10	48	12	30	60	M28x1.5	24	M10
3U-208K	210	137	92	170	133.4	5	52	16	23	11	51	15	30	80	M35x1.5	30	M12
3U-210K	254	152	102	220	171.4	5	75	16	25	15	51	15	30	105	M38x1.5	34	M16
3U-212K	304	157	102	220	171.4	5	100	16	25	15	51	15	30	135	M45x1.5	40	M16

Model	Ll	M	N	P	Q max.	Q min.	R	S	T	Tl	U(H6)	V	W max.	W min.	X
3U-205K	15	20	41.5	M8	13.25	11.75	55	24	25	15.5	45	5	3	-3	M5
3U-206K	16.5	30	50	M10	15.75	13.25	72	30	30	26.5	58	6	5	-5	M5
3U-208K	18	34	63	M12	16.25	13.25	82	35	30	32.5	68	6	5	-7	M6
3U-210K	23	39	74	M14	20.75	18.25	107	40	30	36.5	93	6	5	-5	M8
3U-212K	26	44	74	M14	44.25	41.75	130	40	30	36.5	114	6	5	-5	M10



- Suitable for internal gripping.
- Radial clamp and axial pull down at the same time, keep the workpiece attaching close to the base surface of the chuck.
- Almost no workpiece uplifting displacement.
- With high precision and stability that chuck suitable for end process.
- Airtight pressure detect function is optional.

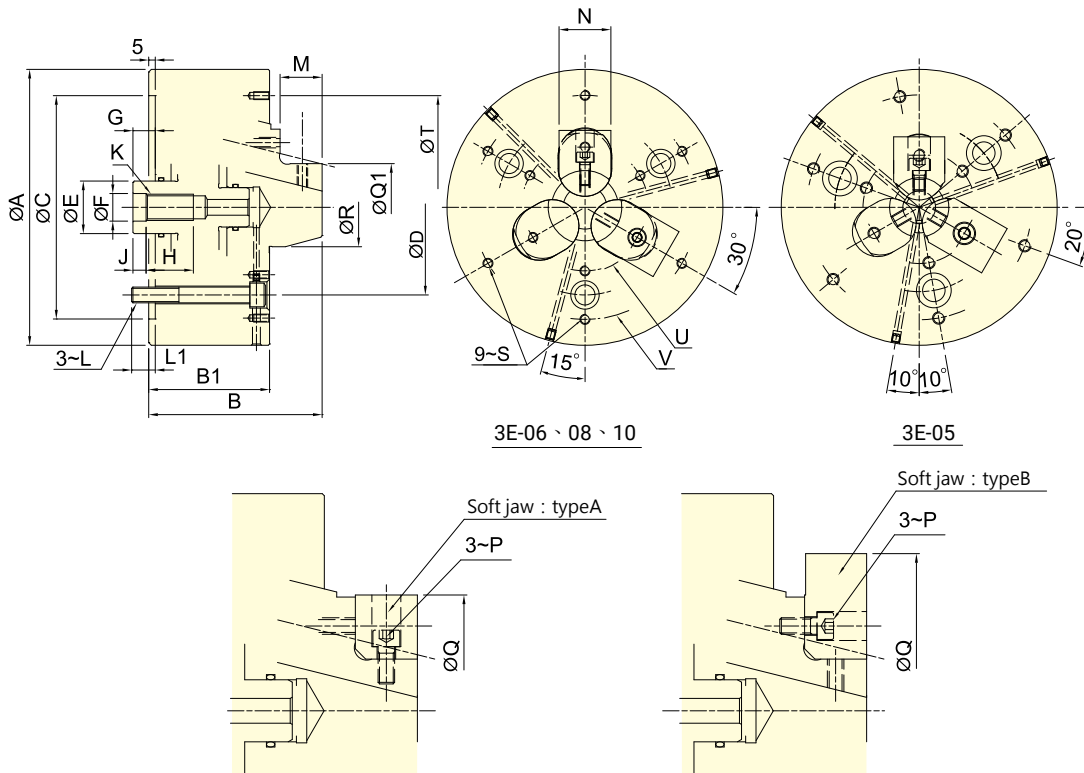

Subject to technical changes

### SPECIFICATIONS

Model	Plunger stroke	Jaw stroke (Dia.)	Chucking Dia.Max.	Chucking Dia.Min.	Max. D.B. pull	Max. Clamping force	Max. speed	Moment of inertia	Weight	Matching cyl.	Max. pressure
	mm	mm	mm	mm	kN (kgf)	kN (kgf)	min <sup>-1</sup> (r.p.m.)	kg · m <sup>2</sup>	kg		MPa (kgf/cm <sup>2</sup> )
<b>3E-05</b>	6	3	83	29	13.0(1325)	42.0(4280)	7000	0.018	7.5	RK-100	1.8(18.5)
<b>3E-06</b>	10	5	110	44	18.0(1835)	58.0(5910)	6000	0.042	13.6	RK-100	2.5(25.6)
<b>3E-08</b>	10	5	150	50	25.0(2530)	80.0(8150)	5000	0.14	26.5	RK-125	2.2(22.5)
<b>3E-10</b>	10	5	190	60	35.0(3570)	100.0(10200)	3600	0.31	39.5	RK-150	2.8(28.5)

### DIMENSIONS

Model	A	B	B1	C (H6)	D	E	F (H8)	G max.	G min.	H	J	K	L	L1
	<b>3E-05</b>	135	98	72	110	82.6	25	18	18	12	25	8	M16	M10
<b>3E-06</b>	165	112	80	140	104.8	35	18	22	12	30	8	M16	M10	16
<b>3E-08</b>	210	135	90	170	133.4	40	21	22	12	36	10	M20	M12	18
<b>3E-10</b>	254	152	102	220	171.4	50	25	25	15	48	10	M24	M16	23

Model	M	N	P	type A		type B		Q1		R	S	T	U (p.c.d)	V (p.c.d)
				Q max.	Q min.	Q max.	Q min.	max.	min.					
<b>3E-05</b>	20	25	M6	68	50	83	67	50	29	25	M6x12	110	55	110
<b>3E-06</b>	23	31	M6	90	70	110	89	70	44	40	M6x12	130	76	134
<b>3E-08</b>	30	35	M8	110	90	150	108	90	50	49	M6x12	170	100	170
<b>3E-10</b>	35	40	M10	127	110	190	125	110	60	59	M8x16	210	120	210





- Swing and grasp the workpiece to three jaw. (3W is automatically positioned to the center type.)
- Suitable for such materials as the casting and forging to process.
- Suitable for heavy machining.
- Seal proof for dust and cutting fluid, it is more convenient when maintenance.
- Swing parts are to heat treatment hardened and ground for steel, in order to improve products service life.
- Swing and grasp the workpiece to three jaw.(3W-C is center compensation type.)
- The workpieces compensation of eccentric is 2 mm, fixed position for the center thimble.

- Carbide gripper is optional. \* The type of the carbide gripper is selected according to the work-piece conditions.
- According to different processing requirements, O.D. Gripping and I.D. Gripping can be interchanged.

### Type of the Carbide gripper

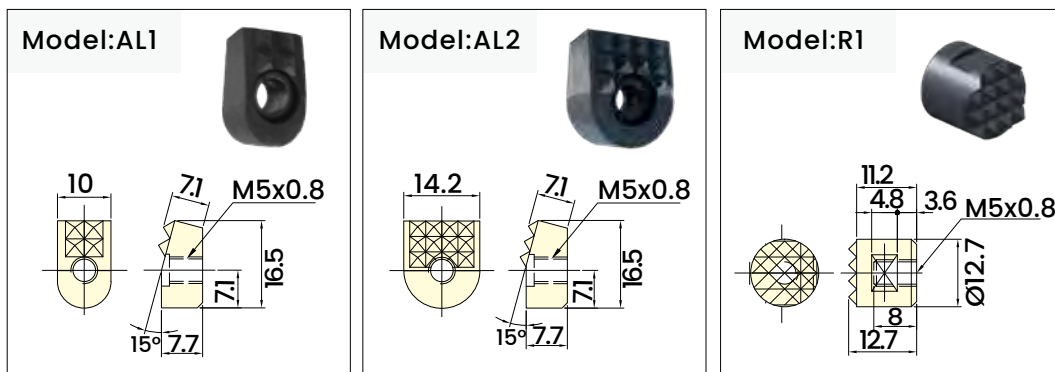

### O.D. Gripping

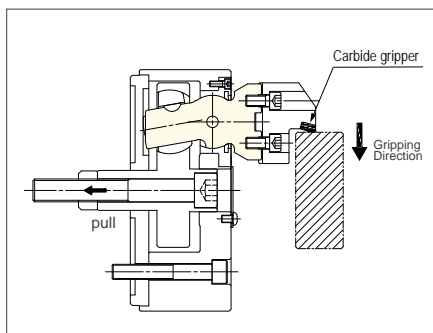

### I.D. Gripping

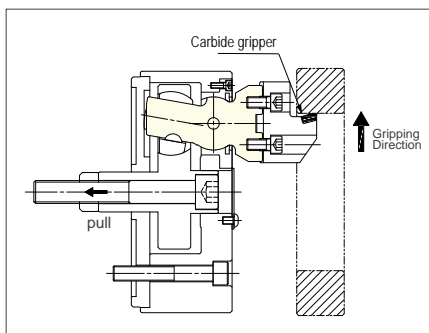

### Min. Gripping range

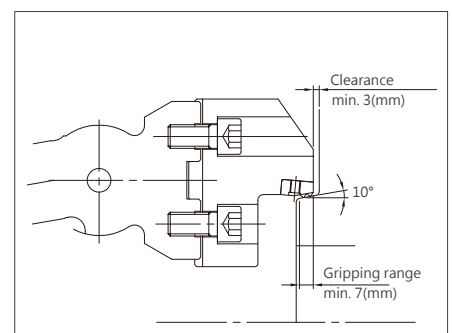

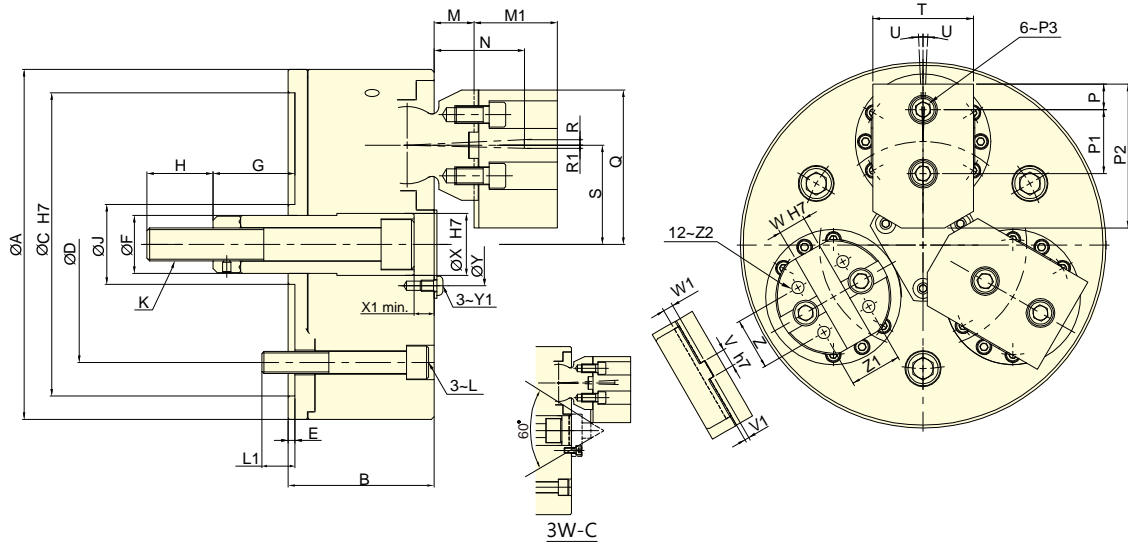

Subject to technical changes

## SPECIFICATIONS

Model	Plunger stroke	Jaw stroke (Dia.)	Chucking O.D.	Chucking I.D.	Max. D.B. pull	Max. clamping force	Max. speed	Moment of inertia	Weight	Matching cyl.	Compensation
	mm	mm	Min.-Max.	Min.-Max.	kN (kgf)	kN (kgf)	min <sup>-1</sup> (r.p.m.)	kg · m <sup>2</sup>	kg		mm
<b>3W-08</b>	14.4	9.8	16~150	76~203	25(2550)	85.0(8670)	3700	0.12	23	RK-100(N)	-
<b>3W-C08</b>	14.4	9.8	16~150	76~203	25(2550)	85.0(8670)	3700	0.12	23	RK-100(N)	2
<b>3W-10</b>	17.5	12.5	50~205	85~235	35.3(3600)	105.9(10800)	2500	0.37	48.6	RK-125(N)	-
<b>3W-C10</b>	17.5	12.5	50~205	85~235	35.3(3600)	105.9(10800)	2500	0.37	48.6	RK-125(N)	2
<b>3W-12</b>	17.5	12.5	63~240	127~305	35.3(3600)	105.9(10800)	2400	0.73	65	RK-125(N)	-
<b>3W-C12</b>	17.5	12.5	63~240	127~305	35.3(3600)	105.9(10800)	2400	0.73	65	RK-125(N)	2
<b>3W-15</b>	22.5	15.9	76~317	165~381	56(5600)	168.2(16800)	2000	1.81	97	RK-150(N)	-
<b>3W-C15</b>	22.5	15.9	76~317	165~381	56(5600)	168.2(16800)	2000	1.81	97	RK-150(N)	3

## DIMENSIONS

Model	A	B	C (H7)	D	E	F	G max.	G min.	H	J	K	L	L1	M	M1	N	P	P1	P2
<b>3W-08</b>	210	89	170	133.4	5	34	51.9	37.5	40	50	M18x2.5	M12	19	19.3	56.5	52.7	16	38	80
<b>3W-C08</b>	210	89	170	133.4	5	34	51.9	37.5	40	50	M18x2.5	M12	19	19.3	56.5	52.7	16	38	80
<b>3W-10</b>	254	106	220	171.4	5	42	67.5	50	48	58	M24x3	M16	24	29	60.5	65.6	17.8	44.4	100
<b>3W-C10</b>	254	106	220	171.4	5	42	67.5	50	48	58	M24x3	M16	24	29	60.5	65.6	17.8	44.4	100
<b>3W-12</b>	304	106	220	171.4	5	42	67.5	50	48	58	M24x3	M16	24	29	60.5	65.6	17.8	44.4	100
<b>3W-C12</b>	304	106	220	171.4	5	42	67.5	50	48	58	M24x3	M16	24	29	60.5	65.6	17.8	44.4	100
<b>3W-15</b>	381	120	300	235	5	55	62.5	40	46	80	M27x3	M20	30	32.4	72	74.3	19	63.5	140
<b>3W-C15</b>	381	120	300	235	5	55	62.5	40	46	80	M27x3	M20	30	32.4	72	74.3	19	63.5	140

Model	P3	Q	R	RI	S	T	U	v (h7)	v1	w (H7)	w1	x(H7)	x1	Y	Y1	Z	Z1	Z2
<b>3W-08</b>	M12	95	2.69	2.24	60	57	2	7.94	3	12.68	7	34	3.5	46	M6	32	32	M10
<b>3W-C08</b>	M12	95	2.69	2.24	60	57	2	7.94	3	12.68	7	34	3.5	46	M6	32	32	M10
<b>3W-10</b>	M12	112	4.03	2.26	72	70	2.5	12.7	3	19.03	7	45	5	60	M8	36	36	M10
<b>3W-C10</b>	M12	112	4.03	2.26	72	70	2.5	12.7	3	19.03	7	45	5	60	M8	36	36	M10
<b>3W-12</b>	M12	132.5	4.03	2.26	92.5	70	2.5	12.7	3	19.03	7	45	5	60	M8	36	36	M10
<b>3W-C12</b>	M12	132.5	4.03	2.26	92.5	70	2.5	12.7	3	19.03	7	45	5	60	M8	36	36	M10
<b>3W-15</b>	M12	172	5.14	2.83	121	80	2	12.7	3	19.03	7	56	3	90	M8	36	36	M10
<b>3W-C15</b>	M12	172	5.14	2.83	121	80	2	12.7	3	19.03	7	56	3	90	M8	36	36	M10



- The workpieces compensation of eccentric is 2 mm, fixed position for the center thimble, swing and grasp the workpiece to three jaw.
- Special seal proof for dust and cutting fluid, it is more convenient when maintenance.
- Swing parts are to heat treatment hardened and ground for steel, in order to improve products service life.

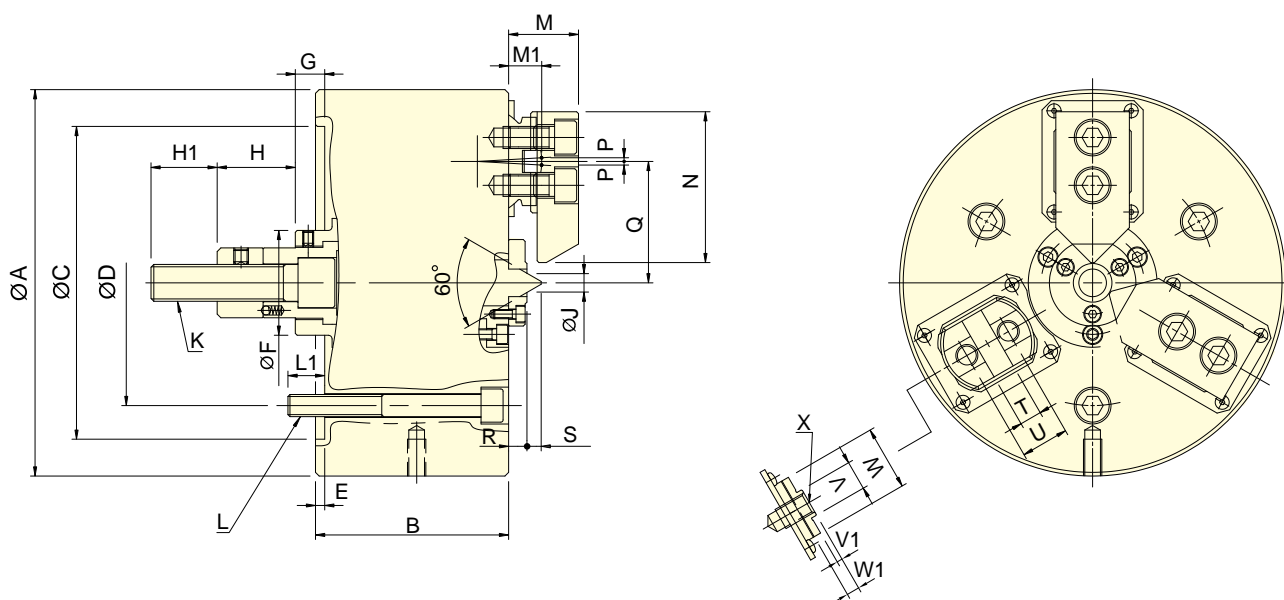

Subject to technical changes

### SPECIFICATIONS

Model	Plunger stroke	Jaw stroke (Dia.)	Chucking Dia. Max.	Chucking Dia. Min.	Max. D.B. pull	Max. clamping force	Max. speed	Moment of inertia	Weight	Matching cyl.	Compensation
	mm	mm	mm	mm	kN (kgf)	kN (kgf)	min <sup>-1</sup> (r.p.m.)	kg · m <sup>2</sup>	kg		mm
<b>3R-08</b>	20	8	65	18	19.6(2000)	53.0(5404)	2800	0.15	27	RK-100N	2
<b>3R-10</b>	25	10	90	22	29.4(3000)	67.7(6901)	2500	0.38	45	RK-125N	2

### DIMENSIONS

Model	A	B	C (H6)	D	E	F	G max.	G min.	H	H1	J	K	L	L1
<b>3R-08</b>	210	105	170	133.4	5	57	26	6	42.5	36	10.4	M20x2.5	3-M12	20
<b>3R-10</b>	254	115	220	171.4	5.5	64	36.5	11.5	25	39	15	M20x2.5	3-M16	22.5

Model	M	M1	N	P	Q max.	Q min.	R	S	T (H7)	U	V	V1	W	W1	X
<b>3R-08</b>	38	18	82	2	68	64	10	7.7	12	26	16	3	35	7	M12
<b>3R-10</b>	40	19	102	2.6	82	78	10	11.3	15	32	18	3	40	7	M14



- Gripping at the end face and preventing deformation of workpiece.
- Suitable for thin wall workpiece processing.
- The gripping compensating mechanism can grasp the irregular surface workpieces well.
- Airtight pressure detect function is optional.

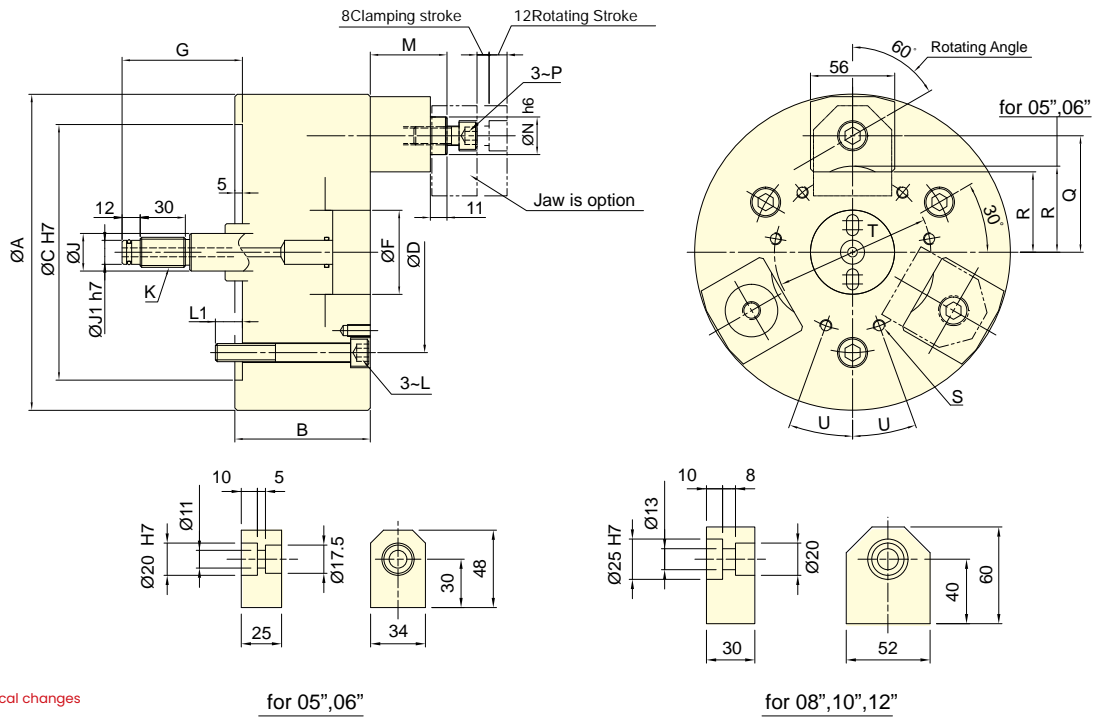

Subject to technical changes

#### SPECIFICATIONS

Model	Rotating stroke	Clamping stroke	Jaw's compensation	Chucking Dia.Max.	Chucking Dia.Min.	Max. D.B. pull	Max. Clamping force	Max. speed	Moment of inertia	Weight	Matching cyl.	Max. pressure
	mm	mm	mm	mm	mm	kN (kgf)	kN (kgf)	min <sup>-1</sup> (r.p.m.)	kg · m <sup>2</sup>	kg		MPa (kgf/cm <sup>2</sup> )
<b>3J-05</b>	12	8	2	53	25	7.5(765)	6.0(612)	4000	0.02	11.0	RK-100 OR RK-100(N)	1.0(10)
<b>3J-06</b>	12	8	2	79	55	9.0(918)	7.5(765)	4000	0.04	12.0	RK-100 OR RK-100(N)	1.2(12)
<b>3J-08</b>	12	8	2	106	75	18.0(1835)	16.5(1680)	3500	0.13	23.0	RK-100 OR RK-100(N)	2.5(25)
<b>3J-10</b>	12	8	2.5	150	119	18.0(1835)	16.5(1680)	3500	0.30	33.0	RK-100 OR RK-100(N)	2.5(25)
<b>3J-12</b>	12	8	2.5	200	169	18.0(1835)	16.5(1680)	3000	0.56	44.0	RK-100 OR RK-100(N)	2.5(25)

#### DIMENSIONS

Model	A	B	C	D	F	G max.	G min.	J	J1	K
<b>3J-05</b>	135	86	110	82.6	40	75	55	25	9	M12x1.75
<b>3J-06</b>	165	86	140	104.8	45	75	55	28	12	M16x2
<b>3J-08</b>	210	90	170	133.4	56	80	60	38	16	M20x2.5
<b>3J-10</b>	254	95	220	171.4	56	75	55	38	16	M20x2.5
<b>3J-12</b>	304	95	220	171.4	56	75	55	38	16	M20x2.5

Model	L	L1	M max.	M min.	N	P	Q	R	S	T	U
<b>3J-05</b>	M10	15	56	36	20	M10	42.5	27	3~M6	50	-
<b>3J-06</b>	M10	15	56	36	20	M10	57.5	40	3~M8	64	-
<b>3J-08</b>	M12	18	71	51	25	M12	77.5	53.5	6~M8	104	20 °
<b>3J-10</b>	M16	24	71	51	25	M12	99.5	75.5	6~M8	140	20 °
<b>3J-12</b>	M16	24	71	51	25	M12	124.5	100.5	6~M8	190	20 °



- Gripping at the end face and preventing deformation of workpiece.
- Suitable for thin wall workpiece processing.
- The gripping compensating mechanism can grasp the irregular surface workpieces well.
- Airtight pressure detect function is optional.

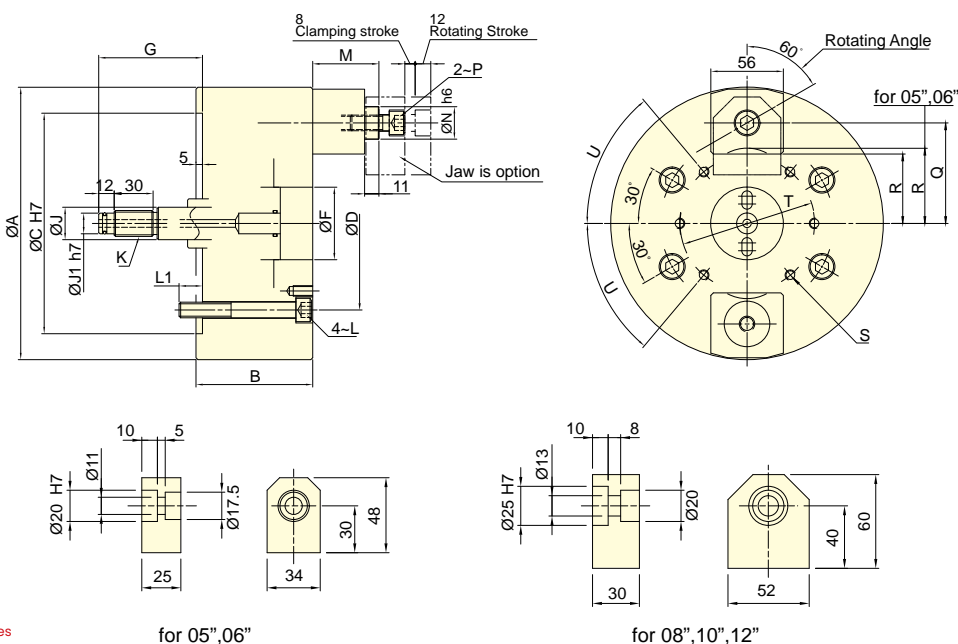

Subject to technical changes

### SPECIFICATIONS

Model	Rotating stroke	Clamping stroke	Jaw's compensation	Chucking Dia. Max.	Chucking Dia. Min.	Max. D.B. pull	Max. Clamping force	Max. speed	Moment of inertia	Weight	Matching cyl.	Max. pressure
	mm	mm	mm	mm	mm	kN (kgf)	kN (kgf)	min <sup>-1</sup> (r.p.m.)	kg · m <sup>2</sup>	kg		MPa (kgf/cm <sup>2</sup> )
<b>2J-05</b>	12	8	2	53	25	5.0(510)	4.0(408)	4000	0.015	9.0	RK-100 OR RK-100(N)	0.7(7)
<b>2J-06</b>	12	8	2	79	55	6.0(612)	5.0(510)	4000	0.035	9.8	RK-100 OR RK-100(N)	0.8(8)
<b>2J-08</b>	12	8	2	106	75	12.0(1224)	11.0(1122)	3500	0.12	20.3	RK-100 OR RK-100(N)	1.7(17)
<b>2J-10</b>	12	8	2.5	150	119	12.0(1224)	11.0(1122)	3500	0.28	30.7	RK-100 OR RK-100(N)	1.7(17)
<b>2J-12</b>	12	8	2.5	200	169	12.0(1224)	11.0(1122)	3000	0.52	41.2	RK-100 OR RK-100(N)	1.7(17)

### DIMENSIONS

Model	A	B	C	D	F	G max.	G min.	J	J1	K
<b>2J-05</b>	135	86	110	82.6	40	75	55	25	9	M12x1.75
<b>2J-06</b>	165	86	140	104.8	45	75	55	28	12	M16x2
<b>2J-08</b>	210	90	170	133.4	56	80	60	38	16	M20x2.5
<b>2J-10</b>	254	95	220	171.4	56	75	55	38	16	M20x2.5
<b>2J-12</b>	304	95	220	171.4	56	75	55	38	16	M20x2.5

Model	L	L1	M max.	M min.	N	P	Q	R	S	T	U
<b>2J-05</b>	M10	15	56	36	20	M10	42.5	27	4-M6	50	30 °
<b>2J-06</b>	M10	15	56	36	20	M10	57.5	40	4-M8	64	30 °
<b>2J-08</b>	M12	18	71	51	25	M12	77.5	53.5	6-M8	104	50 °
<b>2J-10</b>	M16	24	71	51	25	M12	99.5	75.5	6-M8	140	50 °
<b>2J-12</b>	M16	24	71	51	25	M12	124.5	100.5	6-M8	190	50 °



- Large through-hole 3-jaw power chuck with build in air cylinder.
- Patented air supply system, it is easy to install and maintain. No abrasion issue of traditional sealed ring. Maintenance cost and time can be saved.

■ Patent numbers :  
 20.2011.101.818.4 / 20.2012.102.498.5(Germany)  
 3169457 / 3178706 (Japan) / EP 2517822 B1 (EU)  
 ZL 2011 2 0141324.9 / ZL 2012 2 0274549.6 (China)  
 M440159 / M415011 (Taiwan) / US8770222 B2 (U.S.A.)  
 0000278076(Italy)

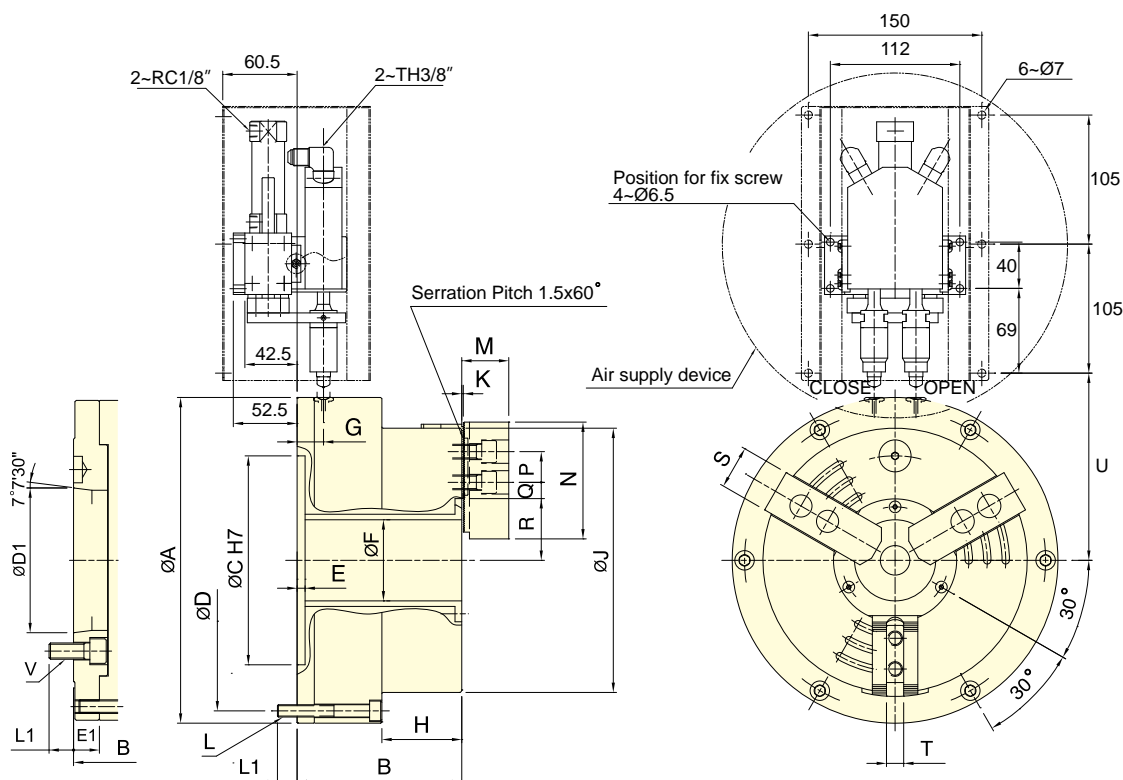

AP-A

Subject to technical changes

## SPECIFICATIONS

Model	Thru-hole Dia.	Jaw stroke (Dia.)	Chucking Dia. Max.	Chucking Dia. Min.	Max. pressure	Max. Clamping force	Max. speed	Moment of inertia	Weight	Air Consumption	
	mm	mm	mm	mm	MPa (kgf/cm <sup>2</sup> )	kN (kgf)	min <sup>-1</sup> (r.p.m.)	kg · m <sup>2</sup>	kg	lit (at 6kgf/cm <sup>2</sup> )	
AP-52	A6	52	5.9	170	15	0.6(6.1)	40.5(4128)	3900	0.2	26 <b>30</b>	3.1
AP-66	A6	66	7.6	215	24	0.6(6.1)	50(5097)	3000	0.4	38 <b>45</b>	5.1
AP-86	A8	86	8.9	268	43	0.6(6.1)	80(8156)	2800	0.7	58 <b>72</b>	8.7
AP-115	A8	115	10.6	330	55	0.6(6.1)	90(9174)	2000	1.7	92 <b>112</b>	12

## DIMENSIONS

Model	A	B	C	D	DI	E	E1	F	G	H	J	K	L		
AP-52	A6	235	121	<b>140</b>	170	215	<b>106.38</b>	6.5	<b>19</b>	52	21.5	58.5	170	2	6~M10
AP-66	A6	265	134	<b>153</b>	170	245	<b>106.38</b>	6.5	<b>19</b>	66	21.5	65	215	2	6~M10
AP-86	A8	315	142	<b>169</b>	220	295	<b>139.72</b>	6.5	<b>27</b>	86	21.5	67	268	2	6~M10
AP-115	A8	370	154	<b>181</b>	220	350	<b>139.72</b>	6.5	<b>27</b>	115	21.5	69	330	2	6~M10

Model	LI	M	N	P	Q max.	Q min.	R max.	R min.	S	T	U	V		
AP-52	A6	15	<b>18</b>	37	73	20	21.2	9.2	38	35.1	31	12	145.5	<b>6~M12</b>
AP-66	A6	16	<b>18</b>	38	95	25	23.7	8.7	50.2	46.4	35	14	159.5	<b>6~M12</b>
AP-86	A8	16	<b>24</b>	43	110	30	32.2	12.7	62.2	57.8	40	16	184.5	<b>6~M16</b>
AP-115	A8	16	<b>24</b>	51	130	30	44.7	14.7	77	71.7	50	21	212	<b>6~M16</b>

1. The dimensions and the specifications of AP-A type are in red data.



- Large through-hole 3-jaw power chuck with build in air cylinder.
- With build-in "pressure detection" device in chuck which can check the pressure is lowered rapidly within the chuck, guarantee to the security of operating.
- Patented air supply system, it is easy to install and maintain. No abrasion issue of traditional sealed ring. Maintenance cost and time can be saved.

■ Patent numbers :  
 20.2011.101.818.4 / 20.2012.102.498.5 (Germany)  
 3169457 / 3178706 (Japan) / EP 2517822 B1 (EU)  
 ZL 2011 2 0141324.9 / ZL 2012 2 0274549.6 (China)  
 M440159 / M415011 (Taiwan) / US8770222 B2 (U.S.A.)  
 0000278076 (Italy)

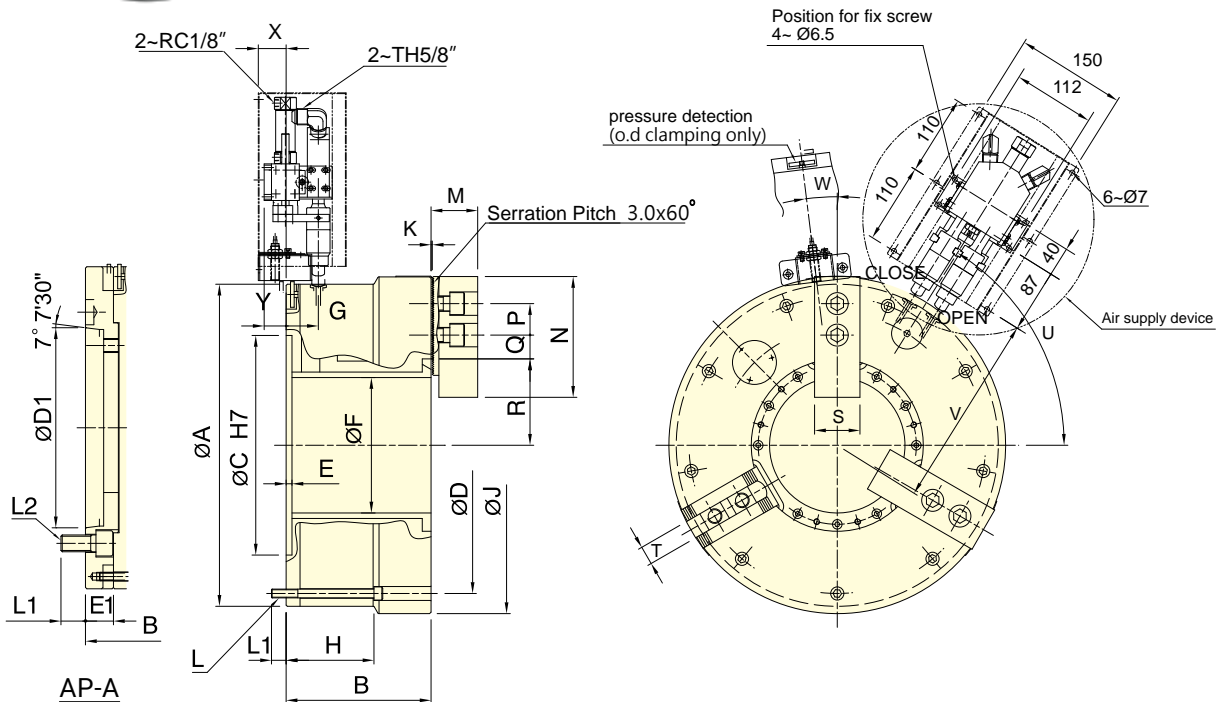

Subject to technical changes

## SPECIFICATIONS

Model		Thru-hole Dia.	Jaw stroke (Dia.)	Chucking Dia.Max.	Chucking Dia.Min.	Max. pressure	Max. Clamping force	Max. speed	Moment of inertia	Weight	Air Consumption	
		mm	mm	mm	mm	MPa (kgf/cm <sup>2</sup> )	kN (kgf)	min <sup>-1</sup> (r.p.m.)	kg · m <sup>2</sup>	kg	lit(at 6kgf/cm <sup>2</sup> )	
AP-145	A11	145	14	420	62	0.6(6.1)	110(11213)	1500	3.8	156	182	17.8
AP-185	A15	185	14	460	100	0.6(6.1)	160(16310)	1700	6.0	188	223	22
AP-230	A15	230	17	535	170	0.6(6.1)	150(15290)	1300	11.1	265	310	34
AP-275	A20	275	17	580	200	0.6(6.1)	160(16310)	1100	15.5	301	346	39
AP-320	A20	320	17	658	200	0.6(6.1)	180(18348)	1000	27.2	415	505	45
AP-375	A20	375	24	738	260	0.6(6.1)	210(21406)	900	44.2	530	545	55

## DIMENSIONS

Model	A	B	C	D	DI	E	EI	F	G	H	J	K	L	LI			
AP-145	A11	400	198	231	300	365	196.87	8	33	145	34	120	420	3.5	9-M12	20	31
AP-185	A15	460	198	238	300	405	285.78	8	40	185	44	120	460	3.5	9-M12	20	35
AP-230	A15	515	226	266	380	483	285.78	8	40	230	49	145	535	3.5	6-M16	24	35
AP-275	A20	560	232	272	380	528	412.78	8	40	275	52	152	580	3.5	6-M16	24	35
AP-320	A20	615	256	306	520	580	412.78	8	50	320	55	116.5	658	3.5	9-M16	25	33
AP-375	A20	690	272	322	520	650	412.78	8	50	375	55	127	738	3.5	9-M16	28	33

Model	L2	M	N	P	Q max.	Q min.	R max.	R min.	S	T	U	V	W	X	Y	
AP-145	A11	6~M20	63.7	165	43	53.5	23.5	98	91	62	25.5	57°	242	0°	38	20
AP-185	A15	6~M24	63.7	165	43	53.5	23.5	118	111	62	25.5	58°	272	7°	38	20
AP-230	A15	6~M24	71.7	180	60	48.5	18.5	145	136.5	64	25.5	30°	300	7°	33	15
AP-275	A20	6~M24	71.7	180	60	48.5	18.5	167.5	159	64	25.5	30°	322	7°	30	12
AP-320	A20	6~M24	81.5	210	60	60.5	24.5	190	181.5	74	30	52°	350	7°	27	9
AP-375	A20	6~M24	81.5	210	60	66.5	24.5	223.5	211.5	74	30	52°	387	7°	27	9

1. The dimensions and the specifications of AP-A type are in red data.

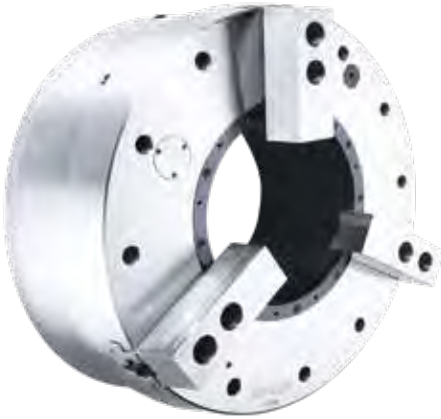

- Large through-hole 3-jaw power chuck with build in air cylinder.
  - With build-in "pressure detection" device which can check the rapidly decreasing pressure within the chuck, guarantee to the security when operating.
  - Patented air supply system, it is easy to install and maintain. No abrasion issue of traditional sealed ring. Maintenance cost and time can be saved.
  - The build-in "clamping detection" device can avoid jaws clamping the workpiece during the rapid stroke stage. This mechanism can also prevent causing the damage of the internal parts or flying out of workpiece.(only for external clamping)
  - Extended jaw stroke design can shorten the processing time when gripping.
- Notice:No clamping in rapid stroke period.

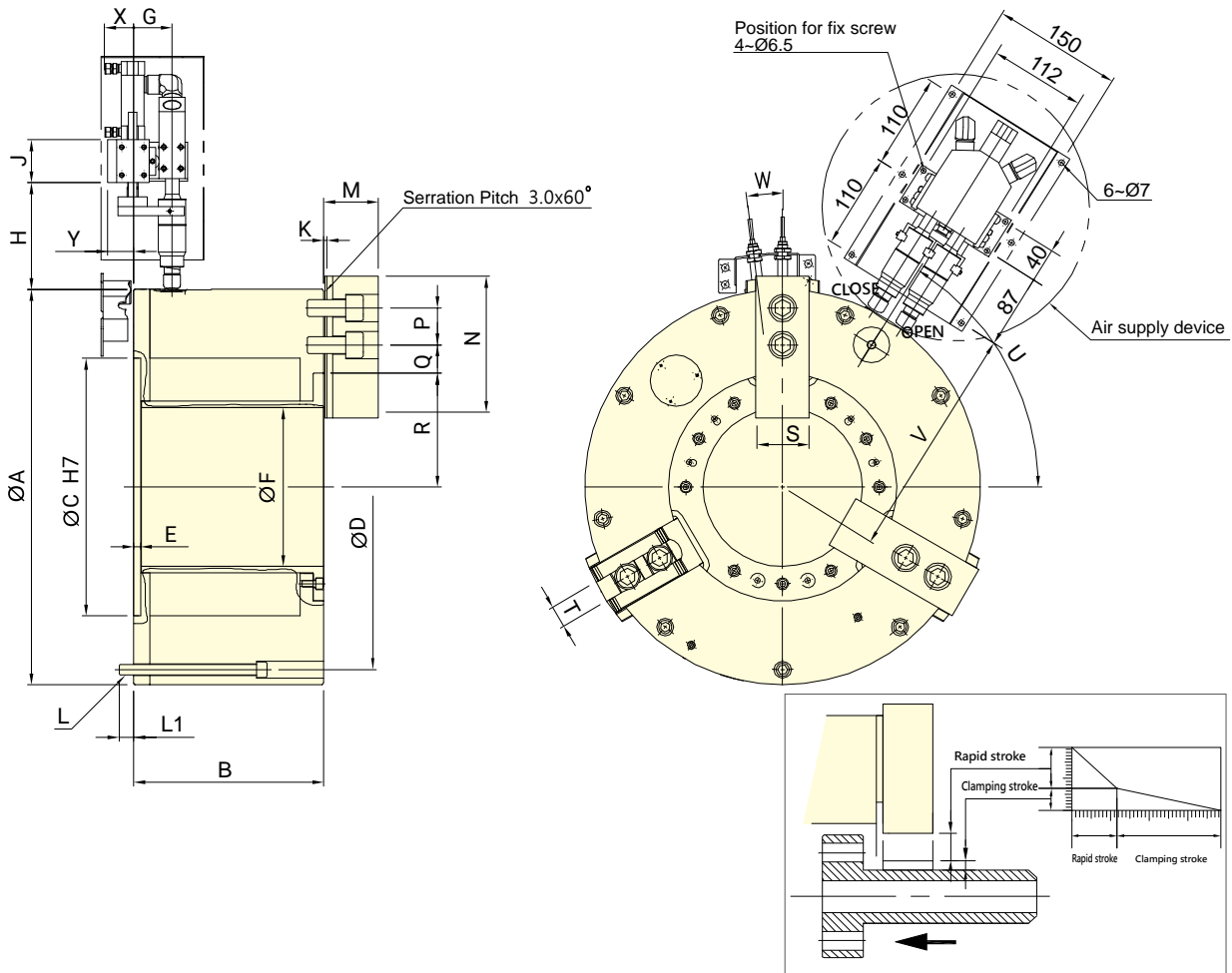

Subject to technical changes

### SPECIFICATIONS

Model	Thru-hole Dia.		Jaw stroke (Dia.)		Chucking Dia. Max.	Chucking Dia. Min.	Max. Clamping force	Max. speed	Moment of inertia	Weight	Air Consumption
	mm	mm	mm	mm	mm	mm	kN (kgf)	min <sup>-1</sup> (r.p.m.)	kg · m <sup>2</sup>	kg	lit(at 6kgf/cm <sup>2</sup> )
<b>APS-185</b>	185	26	14	460	127		110(11216)	1300	6.45	198	22

### DIMENSIONS

Model	A	B	C	D	E	F	G	H	J	K	L	L1	M
<b>APS-185</b>	460	221	300	425	8	185	45	124	50	3.5	9~M12	17	63.7
Model	N	P	Q max.	Q min.	R max.	R min.	S	T	U	V	W	X	Y
<b>APS-185</b>	165	43	37	17	145	125	62	25.5	58	272	7°	38	30





- Indexing operates during the spindle rotation, can perform a quick change between multiple working axes.
- All parts of chuck hardened, ground and lubricated directly.
- Sealed against swarf, chips and coolant.
- High rigidity and high repeatability precision.
- Unique indexing system and hydraulic system, with pressure detection device in chuck, high reliability.

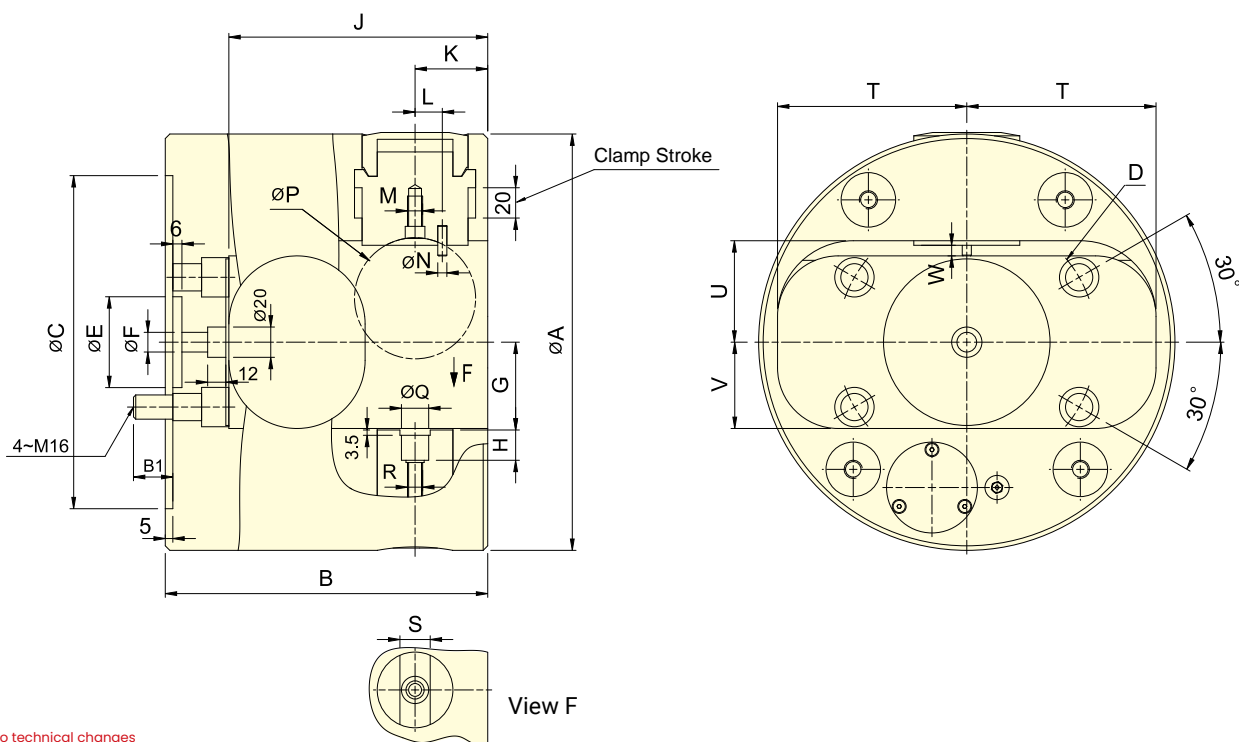

Subject to technical changes

## SPECIFICATIONS

Model	Index Angle	Jaw stroke	Chucking Area Dia Max.	Chucking Area Len Max.	Max. pressure	Max. Clamping force	Max. speed	Moment of inertia	Weight	ROTATING JOINT	Main Spindle Bore
	Deg	mm	mm	mm	kgf/cm <sup>2</sup>	kN (kgf)	min <sup>-1</sup> (r.p.m.)	kg · m <sup>2</sup>	kg		mm
<b>IS-254</b>	4x90°	20	65	160	45	19.5(1990)	2400	0.41	41	IS-315	86+0.1
<b>IS-275</b>	4x90°	20	80	220	45	25.4(2590)	2100	0.61	52	IS-315	86+0.1
<b>IS-315</b>	4x90°	20	100	230	45	25.0(2550)	1800	1.13	76	IS-315	86+0.1

## DIMENSIONS

Model	A	B	B1	C(H6)	D	E	F	G	H	J	K
<b>IS-254</b>	254	190	23	220	171.4	60	13	47.5	18	155	48
<b>IS-275</b>	275	213	26	220	171.4	60	13	58	20	171	48
<b>IS-315</b>	315	232	22	220	171.4	60	13	71	18.5	187	50

  

Model	L	M	N	P	Q(H7)	R	s(H7)	T	U	V	W
<b>IS-254</b>	13	M8	5	40	18	M10	20	106	57	46.5	5.5
<b>IS-275</b>	18	M10	6	80	18	M10	20	125	67	57	7
<b>IS-315</b>	18	M10	6	75	24	M12	25	125	85	70	7.5

\*Index Angle 8x45° or Specific Angle, Please contact AUTOGRIP for more detailed information.Thanks.



- Rotary chuck with built-in pneumatic cylinder, compact design, suitable for light machining, compatible to standard soft jaw/ hard jaw.
  - Can be installed on a rotary table for indexing machining.
  - Sealed against dust and cutting chips.
  - Matching surfaces of all parts hardened, ground and lubricated directly.
- Note: To overcome friction force between distributor ring and chuck body, the rotating torque of rotary table must be higher than the requirement shown in the table.

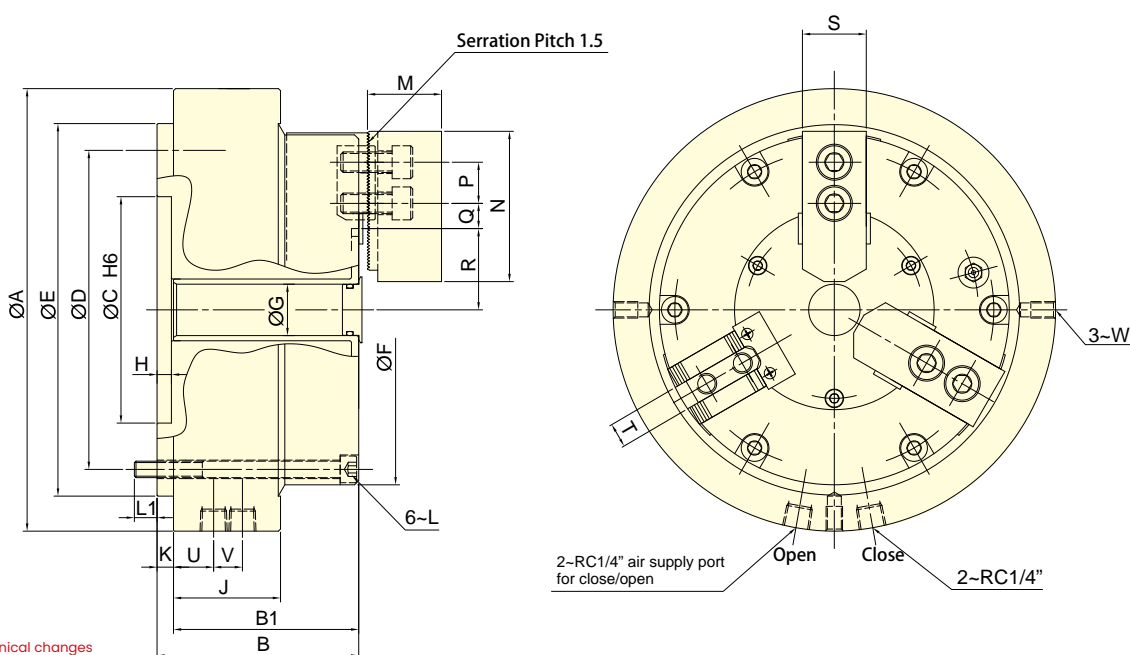

Subject to technical changes

## SPECIFICATIONS

Model	Jaw stroke (Dia.)	Chucking Dia. Max.	Chucking Dia. Min.	Max. clamping force Pneumatic (at 6.0kgf/cm <sup>2</sup> )	Max. pressure	Max. speed	Max Rotation resistance torque	Air consumption (at 6.0 kgf/cm <sup>2</sup> )	Weight
	mm	mm	mm	kN (kgf)	(kgf/cm <sup>2</sup> )	(r.p.m.)	Nm	lit (kgf/cm <sup>2</sup> )	kg
<b>RAP-306</b>	5.5	170	25	21.0(2141.4)	7	72	40	3.1	16.2
<b>RAP-308</b>	6.8	215	37	34.2(3487.4)	7	60	60	3.1	30.6
<b>RAP-310</b>	7	254	53	48.0(4894.7)	7	53	85	4.2	42.4

## DIMENSIONS

Model	A	B	Bl	C (H6)	D	E	F	G	H	J	K
<b>RAP-306</b>	215	98	90	110	155	181	170	25	7	52	8
<b>RAP-308</b>	260	113	104	110	200	226	215	32	8	52	9
<b>RAP-310</b>	300	117	52	140	235	261	254	54	8	52	10

Model	L	Ll	M	N	P	Q max.	Q min.	R max.	R min.	S	T	U	V	W
<b>RAP-306</b>	6-M8	11	36	73	20	10.75	4.75	39.5	36.75	31	12	19.5	14	3-M8
<b>RAP-308</b>	6-M8	16	37	95	25	13.25	8.75	57	53.6	35	14	19.5	14	3-M8
<b>RAP-310</b>	6-M8	14	42	110	30	23.25	12.75	64.5	61	40	16	19.5	14	3-M8