

CNC CENTERLESS GRINDER

BEARING SPINDLE TYPE

PALMARY
PALMARY MACHINERY CO., LTD.

PCB-4520-6

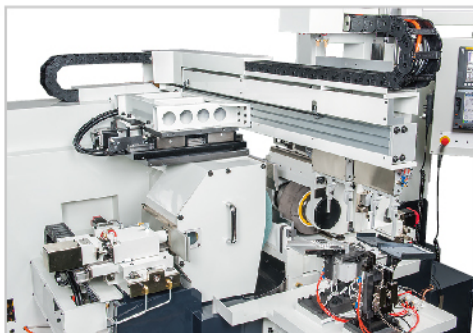
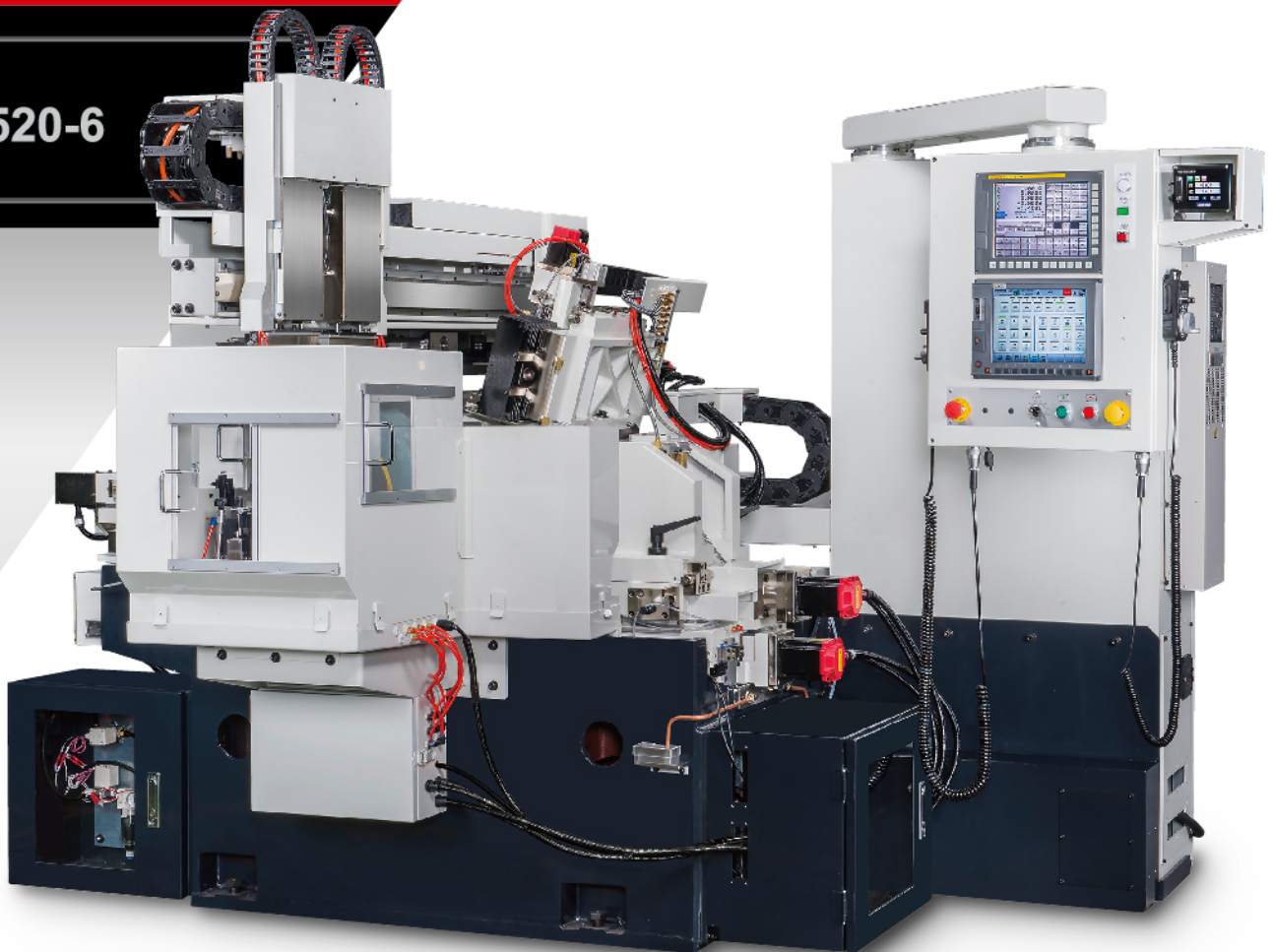

FEATURES

- High grinding accuracy and high rigidity design for max. 6 axes CNC Centerless Grinder bearing spindle type.
- The best configuration for machine bed and structural support ribs makes the grinding accuracies has high stability.
- The grinding wheel spindle single bearing holding type equipped with super precision cylindrical roller bearings for the highest rigidity requirement.
- For different auto application, the high speed loading & unloading attachment is optional to equip.
- The customs design loading device and outer diameter measuring device are also possible as optional for best functional performance.



CNC CENTERLESS GRINDER

BEARING SPINDLE TYPE

SPECIFICATIONS

PCB-4520-6

MODEL	PCB-4520-6	
Capacity	O.D. grinding range	Ø1~Ø80 mm
Grinding Wheel	Size (O.D. x Width x I.D.)	Ø455 x 205 x Ø228.6 mm (opt.: Ø455 x 255 x Ø228.6)
	Linear velocity	Max. 3000 m/min (2100 r.p.m.)
	Motor	11 kw x 4P (opt.: 15 kw x 4P)
	Lubrication	Oil mist type
Regulating Wheel	Size (O.D. x Width x I.D.)	Ø260 x 205 x Ø101.6 mm (opt.: Ø260 x 255 x Ø101.6)
	Linear velocity	10~300 r.p.m. (variable speed)
	Motor	2.0 kw servo motor
	Tilt angle	+5°~-5°
	Swivel angle	+0.5°~-0.5°
	Dressing angle	+5°~-5°
	Lubrication	Oil grease type
	Front & rear micro distance adjustment	+3~-3 mm
Lower Slider	Square slider	Ball screw + reducer
Upper Slider	Square slider	Ball screw + reducer
Lubrication		Forced auto lubricator
Control	CNC	FANUC 0i-TF
Machine Dimensions	(L x W x H)	2870 x 2453 x 2326 mm
Machine Net Weight		3800 kg

OPTIONAL ACCESSORIES

- Fully enclosed splash guard
- Linear scale
- Roller dressing device
- Coolant Separator
- Auto loading/unloading device
- G.W. auto balancing system
- Jib crane for wheel change
- G.W. inverter
- Outer dia. measuring device

• The mentioned specifications & dimensions are subject to change without notice.

MACHINE DIMENSIONS

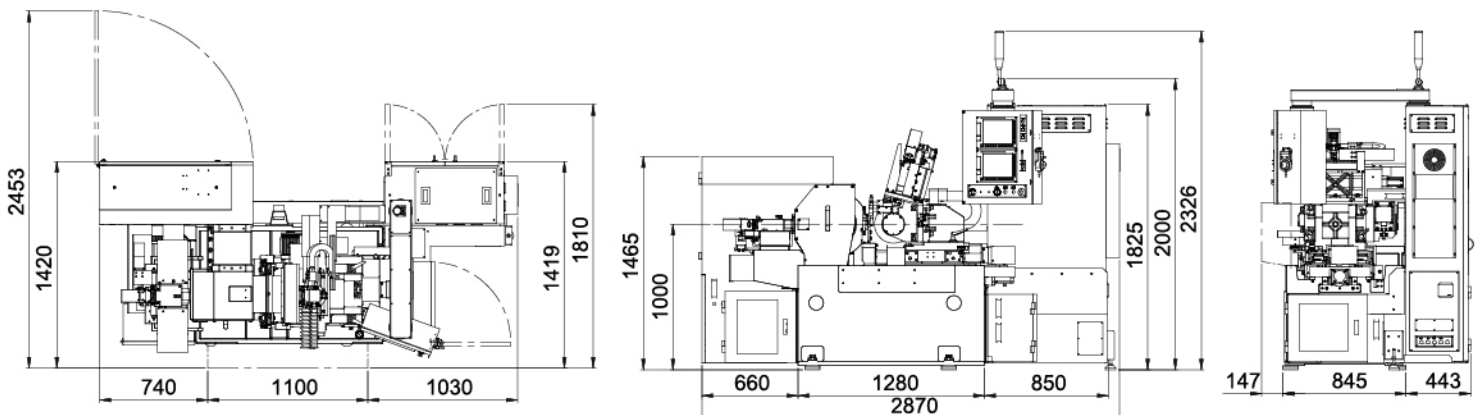

PALMARY MACHINERY CO., LTD.

No. 77, Gongye Rd., Dali Dist., Taichung City 41280, Taiwan.

Tel: +886-4-2492-9799 Fax: +886-4-2492-9499

E-mail: palmary@grinding.com.tw <http://www.grinding.com.tw>

