

Hydrostatic Cylindrical Angular Grinding Machine

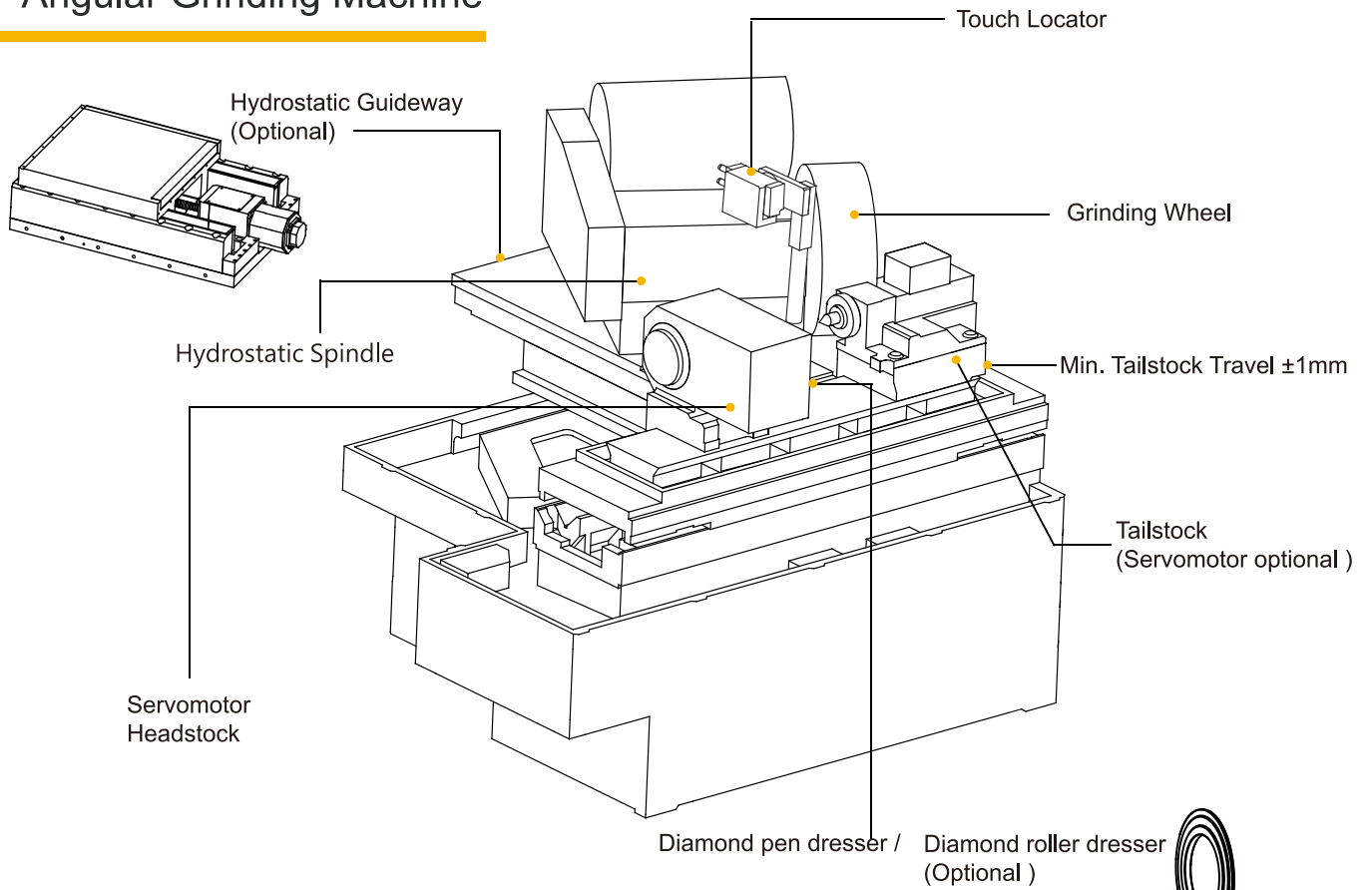

►► Angular grinding process

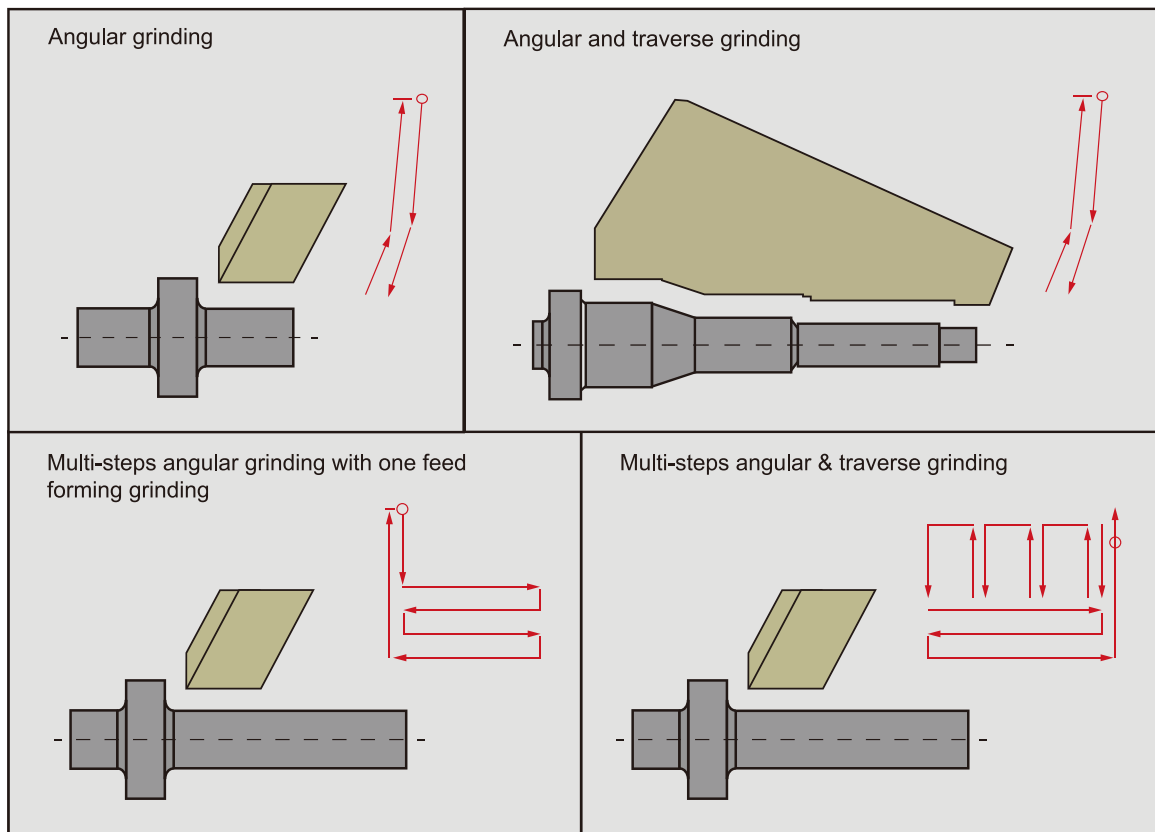

►► Specifiction Table

MODEL	CDC-030/CDC-055	CAC-030/CAC-055	CDC-065	CDC-100
Distance Between Centers	300 /550 mm	300/550 mm	650 mm	1000 mm
Swing Over Table	350 mm	350 mm	400 mm	400 mm
Max. Load Held Between Centers	150 KG	150 KG	150 KG	150 KG
Max. Grinding Diameter	330 mm	330 mm	380 mm	380 mm
Diameter x Width x Bore	Ø510 x 50 x Ø254 mm	Ø610 x 150 x Ø254 mm	Ø455 x 50 x Ø152.4 mm	Ø455 x 50 x Ø152.4 mm
Wheel Speed	0-2000 R.P.M	0-2000 R.P.M	0-2000 R.P.M	0-2000 R.P.M
Max. Peripheral Speed	53 m/sec	63 m/sec	47 m/sec	47 m/sec
Wheel Spindle Motor	7.5 kW/11 kW (10 HP/15 HP)	7.5 kW/11 kW (10 HP/15 HP)	7.5 kW/11 kW (10 HP/15 HP)	7.5 kW/11 kW (10 HP/15 HP)
Workhead Spindle Speed	25-500 R.P.M	25-500 R.P.M	25-500 R.P.M	25-500 R.P.M
Tailstock Stroke	50 mm	50 mm	25 mm	25 mm
Table Swiveling Angle	—	—	-5°~ 9°	-5°~ 9°
Min. Tailstock Travel	±1mm	±1mm	—	—

* Specifications are subjected to change without notice.

Workpiece after ground



Hydrostatic Cylindrical Angular Grinding Machine